

LQ121S1LG81 LCD Module

Preliminary Product Specification

February 2010

SVGA LCD Module featuring true industrial rating with 50,000-hour LED backlight, wide temperature range, wide viewing angles and 450 nits brightness with 800:1 contrast.

SHARP

No.	LD - 22252A
DATE	Feb. 12. 2010

TECHNICAL LITERATURE
FOR
TFT - LCD module

These parts have corresponded with the RoHS directive.

MODEL No. LQ121S1LG81

The technical literature is subject to change without notice.
So, please contact SHARP or its representative before designing
your product based on this literature.

**Engineering department I
Mobile LCD Division II
MOBILE LIQUID CRYSTAL DISPLY GROUP
SHARP CORPORATION**

No.		page
1	Application	1
2	Overview	2
3	Mechanical Specifications	2
4	Input Terminals	3
5	Absolute Maximum Ratings	6
6	Electrical Characteristics	7
7	Timing characteristics of input sig	9
8	Input Signals, Basic Display Colors and Gray Scale of Each Color ..	11
9	Optical Characteristics	12
10	Handling Precautions	14
11	Packing form	15
12	Reliability test items	15
13	Others	16
14	Storage conditions	17

PRELIMINARY

1. Application

This technical literature applies to the color TFT-LCD module LQ121S1LG81.

These technical literature sheets are the proprietary product of SHARP CORPORATION ("SHARP") and include materials protected under copyright of SHARP. Do not reproduce or cause any third party to reproduce them in any form or by any means, electronic or mechanical, for any purpose, in whole or in part, without the express written permission of SHARP.

The device listed in these technical literature sheets was designed and manufactured for use in general electronic equipment.

In case of using the device for applications such as control and safety equipment for transportation (controls of aircraft, trains, automobiles, etc.), rescue and security equipment and various safety related equipment which require higher reliability and safety, take into consideration that appropriate measures such as fail-safe functions and redundant system design should be taken.

Do not use the device for equipment that requires an extreme level of reliability, such as aerospace applications, telecommunication equipment (trunk lines), nuclear power control equipment and medical or other equipment for life support.

SHARP assumes no responsibility for any damage resulting from the use of the device which does not comply with the instructions and the precautions specified in these technical literature sheets.

Contact and consult with a SHARP sales representative for any questions about this device.

2. Overview

This module is a color active matrix LCD module incorporating amorphous silicon TFT (Thin Film Transistor). It is composed of a color TFT-LCD panel, driver ICs, control circuit, power supply circuit and a White-LED Backlight unit. Graphics and texts can be displayed on a 800 × RGB × 600dots panel with about 26 million colors by using LVDS (Low Voltage Differential Signaling) and supplying +3.3V DC supply voltages for TFT-LCD panel driving and +12.0V DC supply voltage for backlight.

The TFT-LCD panel used for this module is a high-brightness and high-contrast image.

The maximum viewing angle is in the 6o'clock direction.

The 12o'clock direction is difficult to reverse the grayscale.

The LED driver circuit and the PWM circuit to drive the backlight are built into the module.

3. Mechanical technical literatures

Parameter	technical literatures	Unit
Display size	31 (12.1inch) Diagonal	cm
Active area	246.0(H) × 184.5(V)	mm
Pixel format	800(H) × 600(V) (1pixel=R+G+B dot)	pixel
Aspect ratio	4:3	
Pixel pitch	0.3075(H) × 0.3075(V)	mm
Pixel configuration	R,G,B vertical stripe	
Display mode	Normally white	
Unit outline dimensions (*1)	276.0(W) × 209.0(H) × 8.7(D)	mm
Mass	T.B.D	g
Surface treatment	Anti-glare and hard-coating 3H	

(*1) excluding the area of the connector cover.

Outline dimensions are shown in Fig.1.

4. Input Terminals

4-1. TFT-LCD panel driving

CN1 (Interface signals and +3.3V power supply)

Using connectors: 20186-020E-11F or FI-SEB20P (I-PEX or Japan Aviation Electronics industry Co., Ltd.)

Corresponding connectors: FI-SE20M or FI-S20S

(Japan Aviation Electronics industry Co., Ltd.)

Using LVDS receiver: Building into cotroll IC(THC63LVDF84B(Thine electronics) or Compatible product)

Corresponding LVDS transmitter: THC63LVDM83R(Thine electronics)

CN1

Pin	Symbol	Function	Remark
1	Vcc	+3.3V Power supply	
2	Vcc	+3.3V Power supply	
3	GND	GND	
4	GND	GND	
5	RxIN0-	LVDS receiver signal CH0 (-)	LVDS
6	RxIN0+	LVDS receiver signal CH0 (+)	LVDS
7	GND	GND	
8	RxIN1-	LVDS receiver signal CH1 (-)	LVDS
9	RxIN1+	LVDS receiver signal CH1 (+)	LVDS
10	GND	GND	
11	RxIN2-	LVDS receiver signal CH2 (-)	LVDS
12	RxIN2+	LVDS receiver signal CH2 (+)	LVDS
13	GND	GND	
14	CK IN-	LVDS receiver signal CK (-)	LVDS
15	CK IN+	LVDS receiver signal CK (+)	LVDS
16	GND	GND	
17	R/L		*1
18	U/D		*1
19	GND	GND	
20	GND	GND	

【*1】 R/L = HIGH, U/D = LOW

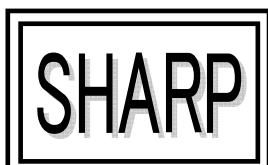

R/L = LOW, U/D = LOW



R/L = HIGH, U/D = HIGH



R/L = LOW, U/D = HIGH



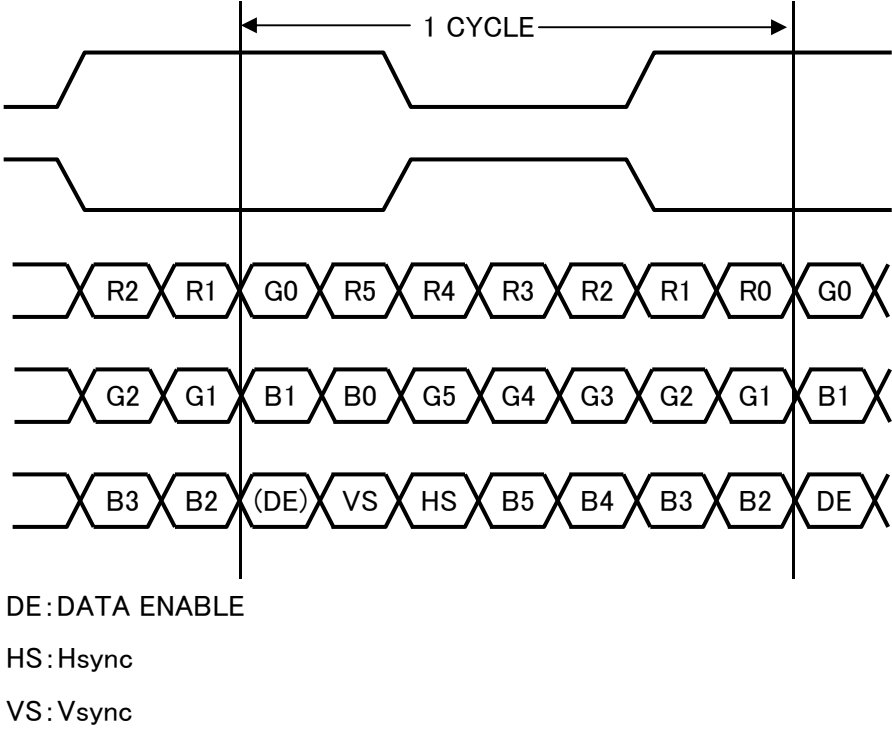

4-2. Interface block diagram

(Computer Side)

(TFT-LCD side)

PRELIMINARY

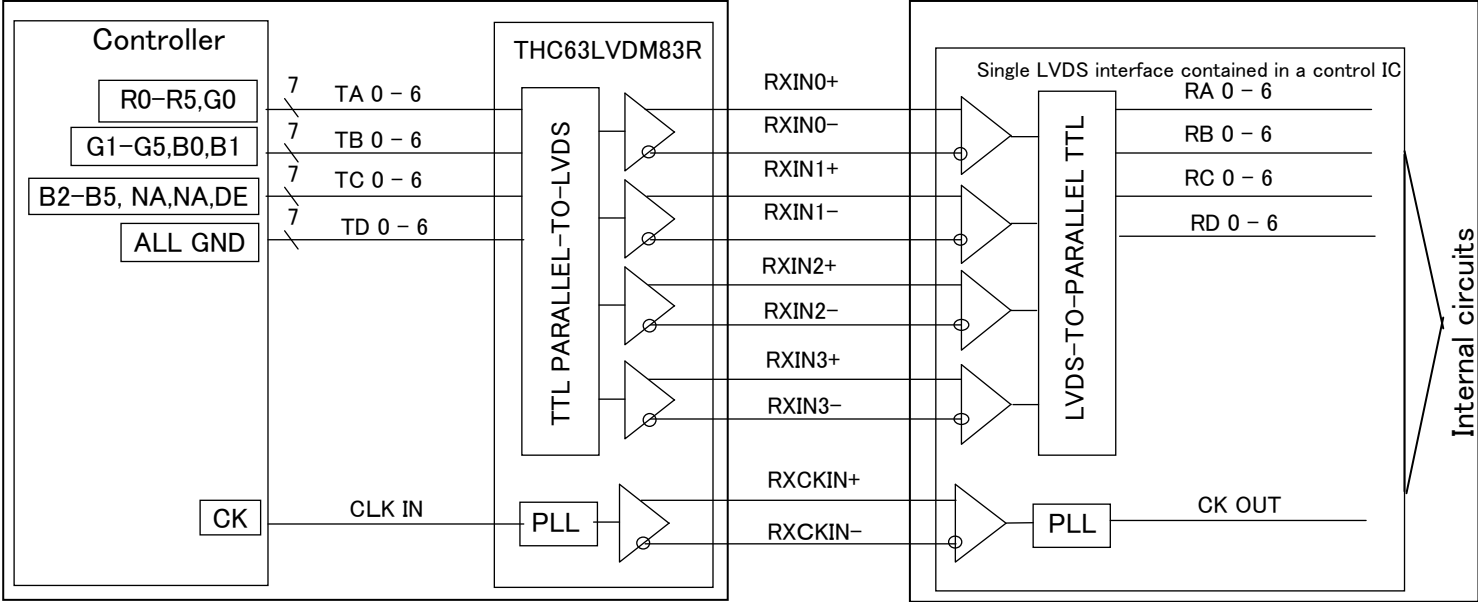

4-3. LED backlight

LED backlight connector

CN2 Used connector : SM06B-SHLS-TF (J.S.T. Mfg. Co. Ltd)

Corresponding connector : SHLP-06V-S-B (J.S.T. Mfg. Co. Ltd)

Connector No.	Pin No.	symbol	function
CN2	1	VDD	+12V power supply
	2	VDD	+12V power supply
	3	GND	GND
	4	GND	GND
	5	XSTABY	Backlight ON/OFF signal
	6	VBR	PWM signal

PRELIMINARY

5. Absolute Maximum Ratings

Parameter	Symbol	Condition	Pin	Ratings	Unit	Remark
Supply voltage	V _{CC}	T _a =25°C	VCC	-0.3 ~ +4.0	V	【*1,2】
	V _{DD}	T _a =25°C	VDD	-0.3 ~ +15.0	V	【*1,2】
Input voltage	V _{I1}	T _a =25°C	RxINi-/+ CK IN-/+	-0.3~V _{CC} +0.3	V	i=0,1,2
	V _{I2}	T _a =25°C	RL/UD,SELLVDS	-0.3~V _{CC} +0.3	V	
	V _{I4}	T _a =25°C	XSTABY, VBR	-0.3~+VDD	V	
Storage temperature	T _{STG}	—	—	-30 ~ +75	°C	【*1】
Operating temperature	T _{OPA}	—	—	-10 ~ +75	°C	【*1,3,4】

【*1】 Humidity: 95%RH Max.(T_a ≤ 40°C) Note static electricity.

Maximum wet-bulb temperature at 39°C or less. (T_a > 40°C) No condensation.

【*2】 The V_{CC} power supply capacity must use the one of 2A or more.

The V_{CC} power supply capacity must use the one of 3A or more.

【*3】 There is a possibility of causing deterioration in the irregularity and others of the screen and the display fineness though the liquid crystal module doesn't arrive at destruction when using it at 65~75°C.

【*4】 In the operating temperature item, the low temperature side is the ambient temperature regulations.

The high temperature side is the panel surface temperature regulations.

6. Electrical Characteristics

6-1. TFT-LCD panel driving

 $T_a = +25^\circ\text{C}$

Parameter	Symbol	Condition	Min.	Typ.	Max.	Unit	Remark
Supply voltage	V_{CC}		3.0	3.3	3.6	V	【*1】
Current dissipation	I_{CC}	$V_{CC}=3.3\text{V}$	—	(400)	(450)	mA	【*2】
Input voltage width for LVDS receiver	V_L		0	—	2.4	V	
Permissive input ripple voltage	V_{RP}		—	—	200	mV_{P-P}	$V_{CC}=3.3\text{V}$
Differential input Threshold voltage	High	V_{TH}	—	—	$V_{CM} + 100$	mV	$V_{CM} = +1.2\text{V}$ 【*3】
	Low	V_{TL}	$V_{CM} - 100$	—	—	mV	
Input voltage	V_{IH}		2.1	—	—	V	【*4】
	V_{IL}		—	—	0.8	V	
Input reak current	I_{OH}		—	—	400	μA	$V_{I2} = +3.3\text{V}$ 【*4】
	I_{OL}		-10	—	+10	μA	$V_{I2} = 0\text{V}$ 【*4】
Terminal resistor	R_T		—	100	—	Ω	Differential input

【*1】 On-off conditions for supply voltage

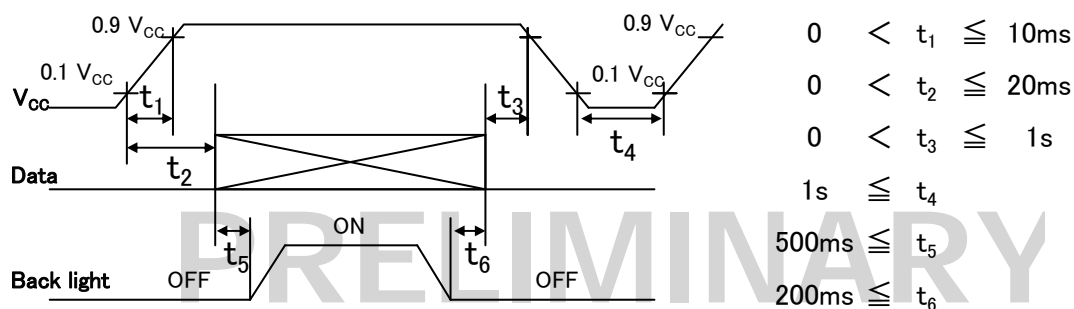

Vcc-dip conditions

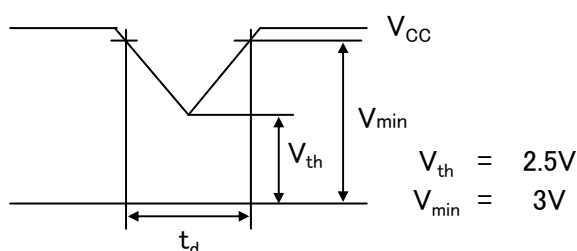

- $V_{th} < V_{CC} \leq V_{min}$
 $t_d \leq 10\text{ms}$
- $V_{CC} < V_{th}$

Vcc-dip conditions should also follow the On-off conditions for supply voltage

- Hsync/Vsync need not be input so that this model may drive only by the ENAB signal. Even if Hsync/Vsync is input, it doesn't become a malfunction.
- The relation between the data input and the backlight lighting will recommend the above-mentioned input sequence. When the backlight is turned on before the panel operates, there is a possibility of abnormally displaying. The liquid crystal module is not damaged.

【*2】 Current dissipation

Typical current situation : 64-gray-bar pattern
 ($V_{CC}=+3.3\text{V}$, $f_{ck} = 40\text{MHz}$, $T_a=25^\circ\text{C}$)

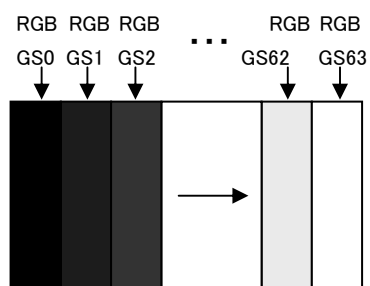

【注3】 V_{CM} : LVDS common mode voltage

【注4】 RL/UD , SELLVDS

6-2. LED backlight

Ta=+25°C

Parameter	Symbol	Min.	Typ.	Max.	Unit	Remark
Supply voltage	V _{DD}	10.2	12.0	13.8	V	【*1】
Current dissipation	I _{DD1}	-	550	650	mA	【*2】
	I _{DD2}	-	-	10.0	μA	
Permissive input ripple voltage	V _{RP_BL}	-	-	200.0	mV _{P-P}	V _{DD} =+12.0V
BL1 input high voltage	V _{IH_BL1}	2.4	-	V _{DD}	V	【*3】
BL1 input Low voltage	V _{IL_BL1}	-	-	0.4	V	【*3】
BL2 input high voltage	V _{IH_BL2}	2.4	-	V _{DD}	V	【*4】
BL2 input low voltage	V _{IL_BL2}	-	-	0.4	V	【*4】
PWM frequency	f _{PWM}	50.0	-	1k	Hz	【*4,5】
PWM duty	D _{PWM}	20.0	-	100.0	%	【*4,5】
Life time	L	-	(50,000) (Module)	-	h	【Reference】 【*6】

【*1】 On-off conditions for supply voltage

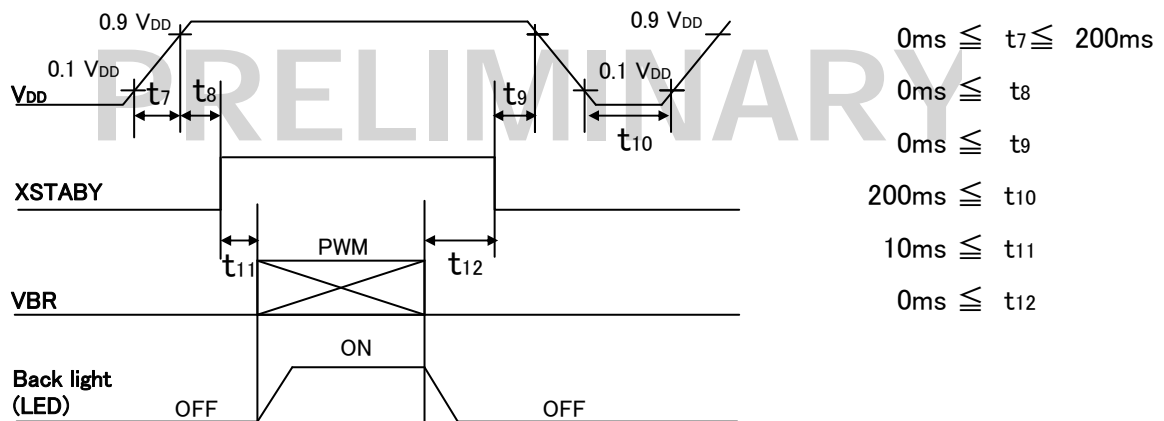

【*2】 Current dissipation

Typ. value: V_{DD}=+12.0V, Duty=100%Max. value: V_{DD}=+10.2V, Duty=100%

【*3】 XSTABY

【*4】 VBR

【*5】 PWM

$$f_{\text{PWM}} = 1/t_{14}$$

Duty 0% : Min. Luminance

Duty 100% : Max. Luminance

Luminance changes in proportion to the duty ratio. (t₁₃ ≥ 10 μs)

When the frequency slows, the display fineness might decrease.

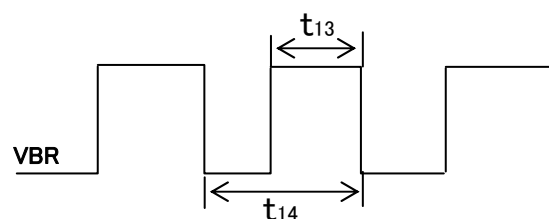

【*6】 Luminance becomes 50% of an initial value. (Ta=25°C, PWM=100%)

7. Timing characteristics of input signals

7-1. Timing characteristics

(Vertical Timing)

Item	Symbol	min	typ	max	unit	remark	
Vertical	Vsync cycle	–	17.6	–	ms		
		628	666	798	line		
	Blanking period	TVB	28	66	–	line	
	Vsync pulse width	TVC	2	4	6	line	
	Back porch	TVD	23	23	23	line	
	Vsync pulse width +Back porch	TVC+TVD	25	27	29	line	
	Active display area	TVE	600	600	600	line	
Front porch	TVF	3	39	–	line		

(Horizontal Timing)

Item	Symbol	min	typ	max	unit	remark	
Horizontal	Hsync cycle	21	26.4	40	μ s		
		832	1056	1395	clock		
	Blanking period	THB	40	256	–	clock	
	Hsync pulse width	THC	2	128	200	clock	
	Back porch	THD	88	88	88	clock	
	Active display area	THE	800	800	800	clock	
フロントポーチ	THF	0	40	–	clock		

(Clock Timing)

Item	Symbol	min	typ	max	unit	remark	
Clock	Frequency	1/Tc	(35)	40	(42)	MHz	

(Hsync-Vsync Phase difference)

Item	Symbol	min	typ	max	unit	remark
Hsync-Vsync Phase difference	THV	1	–	THA-THC	clock	

(Display position)

Item	Symbol	min	typ	max	unit	remark
Vertical	rising edge of Vsync	88		888	clock	
Horizontal	rising edge of Hsync	23		623	line	

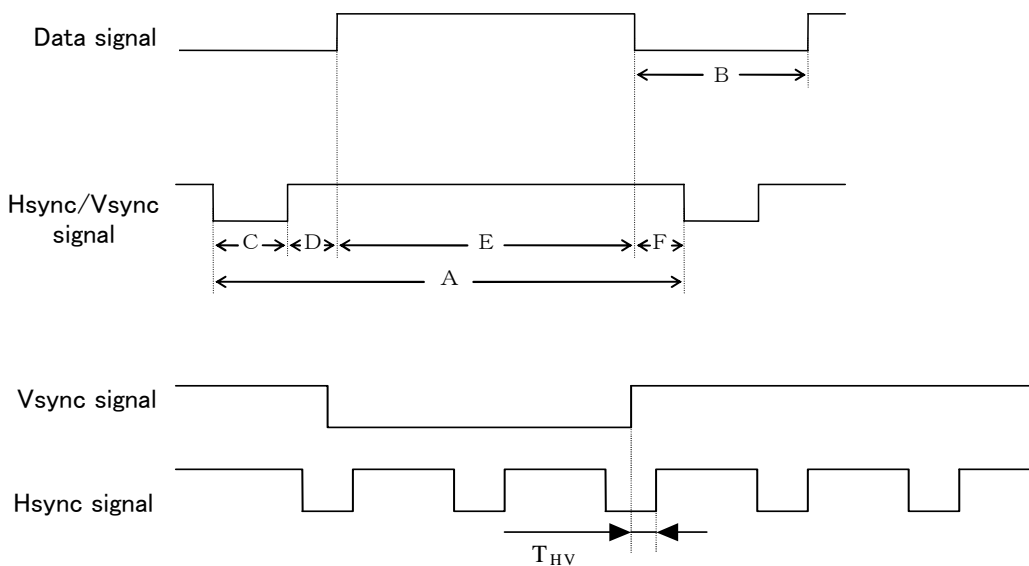

7-2. Input Data Signals and Display Position on the screen

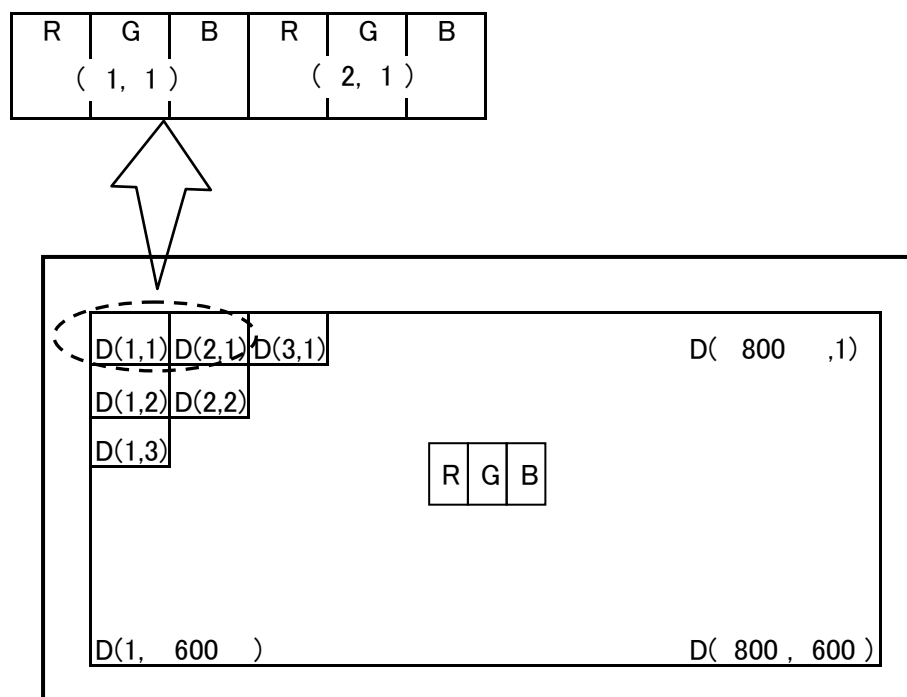

PRELIMINARY

8. Input Signals, Basic Display Colors and Gray Scale of Each Color

	Colors & Gray scale	Data signal																		
		GrayScale	R0	R1	R2	R3	R4	R5	G0	G1	G2	G3	G4	G5	B0	B1	B2	B3	B4	B5
Basic Color	Black	—	0	0	0	0	0	0	0	0	0	0	0	0	0	0	0	0	0	0
	Blue	—	0	0	0	0	0	0	0	0	0	0	0	0	1	1	1	1	1	1
	Green	—	0	0	0	0	0	0	1	1	1	1	1	1	0	0	0	0	0	0
	Cyan	—	0	0	0	0	0	0	1	1	1	1	1	1	1	1	1	1	1	1
	Red	—	1	1	1	1	1	1	0	0	0	0	0	0	0	0	0	0	0	0
	Magenta	—	1	1	1	1	1	1	0	0	0	0	0	0	1	1	1	1	1	1
	Yellow	—	1	1	1	1	1	1	1	1	1	1	1	1	0	0	0	0	0	0
	White	—	1	1	1	1	1	1	1	1	1	1	1	1	1	1	1	1	1	1
Gray Scale of Red	Black	GS0	0	0	0	0	0	0	0	0	0	0	0	0	0	0	0	0	0	0
	↑	GS1	1	0	0	0	0	0	0	0	0	0	0	0	0	0	0	0	0	0
	Darker	GS2	0	1	0	0	0	0	0	0	0	0	0	0	0	0	0	0	0	0
	↑	↓	↓				↓				↓									
	↓	↓	↓				↓				↓									
	Brighter	GS61	1	0	1	1	1	1	0	0	0	0	0	0	0	0	0	0	0	0
	↓	GS62	0	1	1	1	1	1	0	0	0	0	0	0	0	0	0	0	0	0
Red	GS63	1	1	1	1	1	1	0	0	0	0	0	0	0	0	0	0	0	0	
Gray Scale of Green	Black	GS0	0	0	0	0	0	0	0	0	0	0	0	0	0	0	0	0	0	0
	↑	GS1	0	0	0	0	0	0	1	0	0	0	0	0	0	0	0	0	0	0
	Darker	GS2	0	0	0	0	0	0	0	1	0	0	0	0	0	0	0	0	0	0
	↑	↓	↓				↓				↓									
	↓	↓	↓				↓				↓									
	Brighter	GS61	0	0	0	0	0	0	1	0	1	1	1	1	0	0	0	0	0	0
	↓	GS62	0	0	0	0	0	0	0	1	1	1	1	1	0	0	0	0	0	0
Green	GS63	0	0	0	0	0	0	1	1	1	1	1	1	0	0	0	0	0	0	
Gray Scale of Blue	Black	GS0	0	0	0	0	0	0	0	0	0	0	0	0	0	0	0	0	0	0
	↑	GS1	0	0	0	0	0	0	0	0	0	0	0	0	1	0	0	0	0	0
	Darker	GS2	0	0	0	0	0	0	0	0	0	0	0	0	0	1	0	0	0	0
	↑	↓	↓				↓				↓									
	↓	↓	↓				↓				↓									
	Brighter	GS61	0	0	0	0	0	0	0	0	0	0	0	0	1	0	1	1	1	1
	↓	GS62	0	0	0	0	0	0	0	0	0	0	0	0	0	1	1	1	1	1
Blue	GS63	0	0	0	0	0	0	0	0	0	0	0	0	1	1	1	1	1	1	

Each basic color can be displayed in 64 gray scales from 6 bit data signals. According to the combination of total 18 bit data signals, the 262,144-color display can be achieved on the screen.

9. Optical Characteristics

$T_a=+25^{\circ}\text{C}$, $V_{cc}=+3.3\text{V}$

Parameter		Symbol	Condition	Min.	Typ.	Max.	Unit	Remark	
Viewing angle range	Horizontal	θ_{21}, θ_{22}	CR>10	(70)	(80)	-	Deg.	【*1,2,4】	
	Vertical	θ_{11}		(45)	(65)	-	Deg.		
		θ_{12}		(70)	(80)	-	Deg.		
Contrast ratio		CR	optimized angle	(400)	(800)	-		【*2,4】	
Response Time	White Black	$\tau_r + \tau_d$	$\theta = 0^{\circ}$	-	(30)	-	ms	【*3,4】	
Chromaticity of White	W_x			(0.250)	(0.300)	(0.350)		【*4】	
	W_y			(0.270)	(0.320)	(0.370)			
Chromaticity of Red	R_x			(0.510)	(0.560)	(0.610)			
	R_y			(0.275)	(0.325)	(0.375)			
Chromaticity of Green	G_x			(0.285)	(0.335)	(0.385)			
	G_y			(0.545)	(0.595)	(0.645)			
Chromaticity of Blue	B_x			(0.105)	(0.155)	(0.205)			
	B_y			(0.070)	(0.120)	(0.170)			
Luminance of white		Y_{L1}			(350)	(450)	-		cd/m^2
White Uniformity				-	-	1.33			【*5】

※The measurement shall be executed 30 minutes after lighting at rating.

The optical characteristics shall be measured in a dark room or equivalent state with the method shown in Fig.2 below.

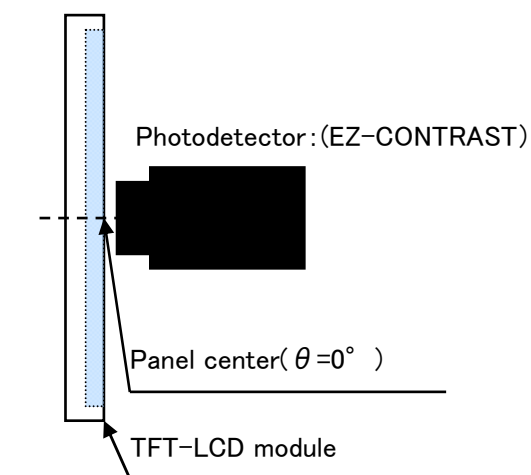

fig.2-1 Measuring method of Viewing angle range.

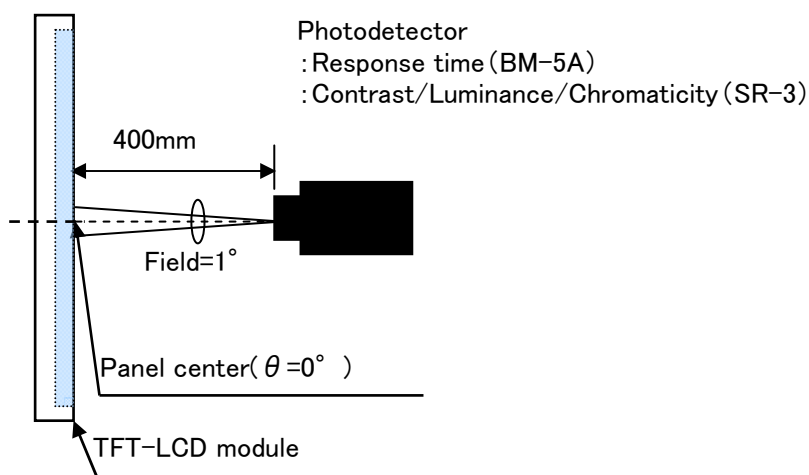
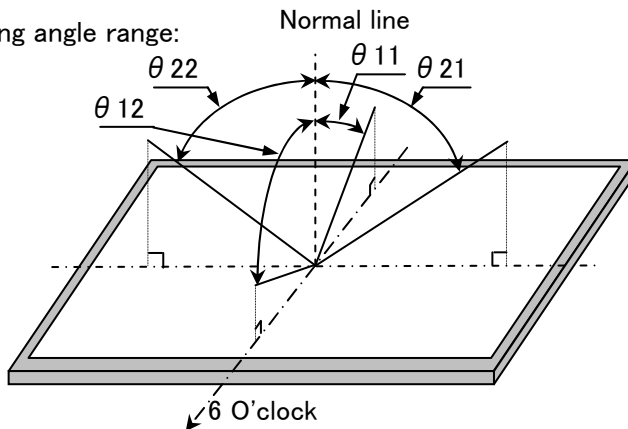

fig.2-2 Measuring method of contrast, luminance, response time, and Chromaticity.

Fig.2 Optical characteristics measurement method

【*1】Definitions of viewing angle range:



【*2】Definition of contrast ratio:

The contrast ratio is defined as the following.
$$\text{Contrast (CR)} = \frac{\text{Luminance with all pixels white}}{\text{Luminance with all pixels black}}$$

【*3】Definition of response time:

The response time is defined as the following figure and shall be measured by switching the input signal for "black" and "white".

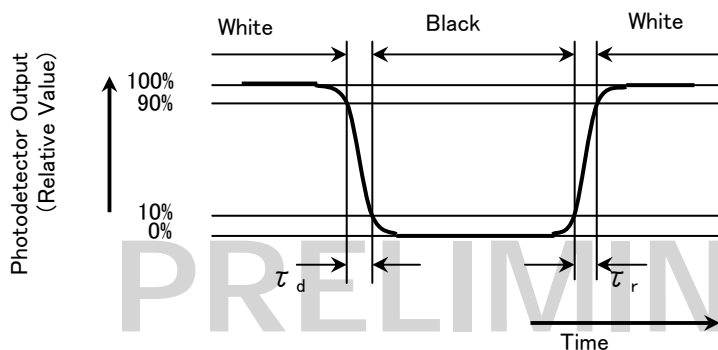

【*4】This shall be measured at center of the screen.

【*5】Definition of white uniformity:

White uniformity is defined as the following with five measurements.

(①~⑤)

$$\delta_w = \frac{\text{Maximum luminance of 5 points(①~⑤)}}{\text{Minimum luminance of 5 points(①~⑤)}}$$

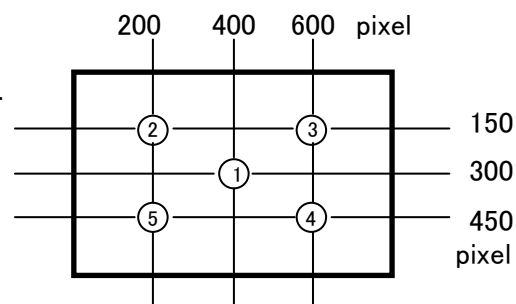

10. Handling Precautions

- a) Be sure to turn off the power supply when inserting or disconnecting the cable.
- b) Since the front polarizer is easily damaged, pay attention not to scratch it.
- c) Wipe off water drop immediately. Long contact with water may cause discoloration or spots.
- d) When the panel surface is soiled, wipe it with absorbent cotton or other soft cloth.
- e) Since the panel is made of glass, it may break or crack if dropped or bumped on hard surface.
Handle with care.
- f) Since CMOS LSI is used in this module, take care of static electricity and injure the human earth when handling. Observe all other precautionary requirements in handling components.
- g) Since there is a circuit board in the module back, stress is not added at the time of a design assembly. Please make it like. If stress is added, there is a possibility that circuit parts may be damaged.
- h) It causes an irregular display and the defective indication, etc., when always put constant pressure on the back of the module.
Please do not make the structure to press the back of the module.
- i) Do not expose the LCD panel to direct sunlight. Lightproof shade etc. should be attached when LCD panel is used under such environment.
- j) Connect GND to stabilize against EMI and external noise.
- k) When handling LCD modules and assembling them into cabinets, please avoid that long-terms storage in the environment of oxidization or deoxidization gas and the use of such materials as reagent, solvent, adhesive, resin, etc. which generate these gasses, may cause corrosion and discoloration of the modules. Do not use the LCD module under such environment.
- l) Liquid crystal contained in the panel may leak if the LCD is broken. Rinse it as soon as possible if it gets inside your eye or mouth by mistake.
- m) Be careful when using it for long time with fixed pattern display as it may cause accidental image.
- n) Adjusting volume have been set optimally before shipment, so do not change any adjusted value. If adjusted value is changed, the specification may not be satisfied.
- o) If a minute particle enters in the module and adheres to an optical material, it may cause display non-uniformity issue, etc. Therefore, fine-pitch filters have to be installed to cooling and inhalation hole if you intend to install a fan.
- p) An abnormal display by changing in quality of the polarizing plate might occur regardless of contact or no contact to the polarizing plate, because of epoxy resin (amine system curing agent) that comes out from the material and the packaging material used for the set side, the silicon adhesive (dealcoholization system and oxime system), and the tray blowing agents (azo-compound), etc. Please confirm adaptability with your employed material.
- q) The polarizer surface on the panel is treated with Anti-Glare for low reflection. In case of attaching protective board over the LCD, be careful about the optical interface fringe etc. which degrades display quality.
- r) Notice : Never take to pieces the module , because it will cause failure. Please do not peel off the Black tape pasted to the product.

11. Packing form

T.B.D

12. Reliability test items

No.	Test item	Conditions	Remark
1	High temperature storage test	Ambient temperature 75°C 240H	【Note1】
2	Low temperature strage test	Ambient temperature -30°C 240H	【Note1】
3	High temperature & high humidity operation test	Ambient temperature 40°C、Humidity 95% RH 240H (No condensation.)	【Note1】
4	High temperature operation test	Panel surface 75°C 240H	【Note1】
5	Low temperature operation test	Ambient temperature -10°C 240H	【Note1】
6	Vibration test	<Sin wave> Frequency : 10~57Hz/Vibration width (one side) : 0.075mm : 57~500Hz/Gravity : 9.8m/s ² Sweep time : 11minutes Test period : 3H(X, Y, Z direction 1H)	【Note1】
7	Shock test	Max. gravity: 490m/s ² Pulse width: 11ms Direction: ±X, ±Y, ±Z Test period : 1time/1direction	【Note1】
8	Thermal shock test	-20°C[0.5h]~75°C[0.5h]/50cycles	【Note1】

【Note1】 Under the display quality test conditions with normal operation state, these shall be no change which may affect practical display function. (normal operation state: Temperature:15~35°C, Humidity:45~75%, Atmospheric pressure:86~106kpa)

13. Others

13-1. Lot No Label:

A) Module serial label

The label that displays SHARP·Model No.(LQ121S1LG81)·Lot No. is stuck on the back of the module.

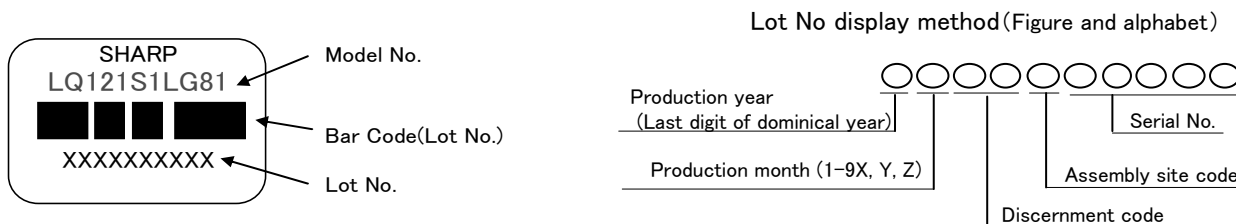

B) Backlight serial label

The label that displays the model No. and lot No. for the backlight is stuck on the back of the module.

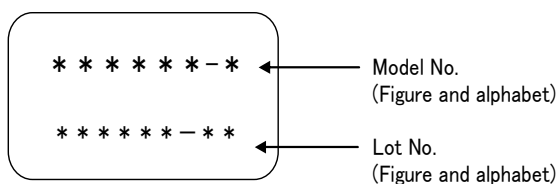

13-2. Packing box Label:

The label that displays ①Model number (LQ121S1LG81) ②Lot number ③Quantity of module is stuck on the packing box. Moreover, the display of bar code also applies to this.

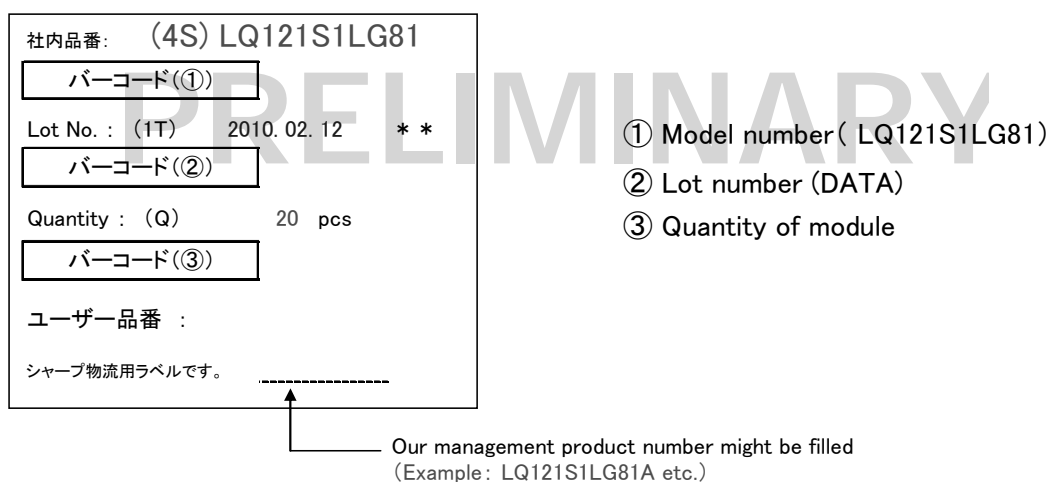

A right picture is written to the packing box of module for the RoHS restriction.

※ R.C.(RoHs Compliance)means these parts have corresponded with the RoHs directive.

This module corresponds from the first sample to RoHS Directive.

R.C.

13-3. The ozone-depleting substances is not used.

13-4. If any problem occurs in relation to the description of this technical literature, it shall be resolved through discussion with spirit of cooperation.

14. Storage conditions

Environmental condition range of storage temperature and humidity

Temperature 0 to 40 degrees Celsius

Relative humidity 95% and below

【Note】Please refer below as a mean value of the environmental conditions.

Summer time temperature 20 to 35 degrees Celsius humidity , 85% and below

Winter time temperature 5 to 15 degrees Celsius humidity , 85% and below

Please maintain within 240 hours of accumulated length of storage time, with conditions of 40 degrees Celsius and room humidity of 95%.

Direct sun light

Please keep the product in a dark room or cover the product to protect from direct sun light.

Atmospheric condition

Please refrain from keeping the product with possible corrosive gas or volatile flux.

Prevention of dew

Please store the product carton either on a wooden pallet or a stand / rack to prevent dew.

Do not place directly on the floor. In addition, to obtain moderate ventilation in between the pallet's top and bottom surfaces, pile the cartons up in a single direction and in order.

Please place the product cartons away from the storage wall.

Storage period

Within above mentioned conditions, maximum storage period should be one year.

PRELIMINARY

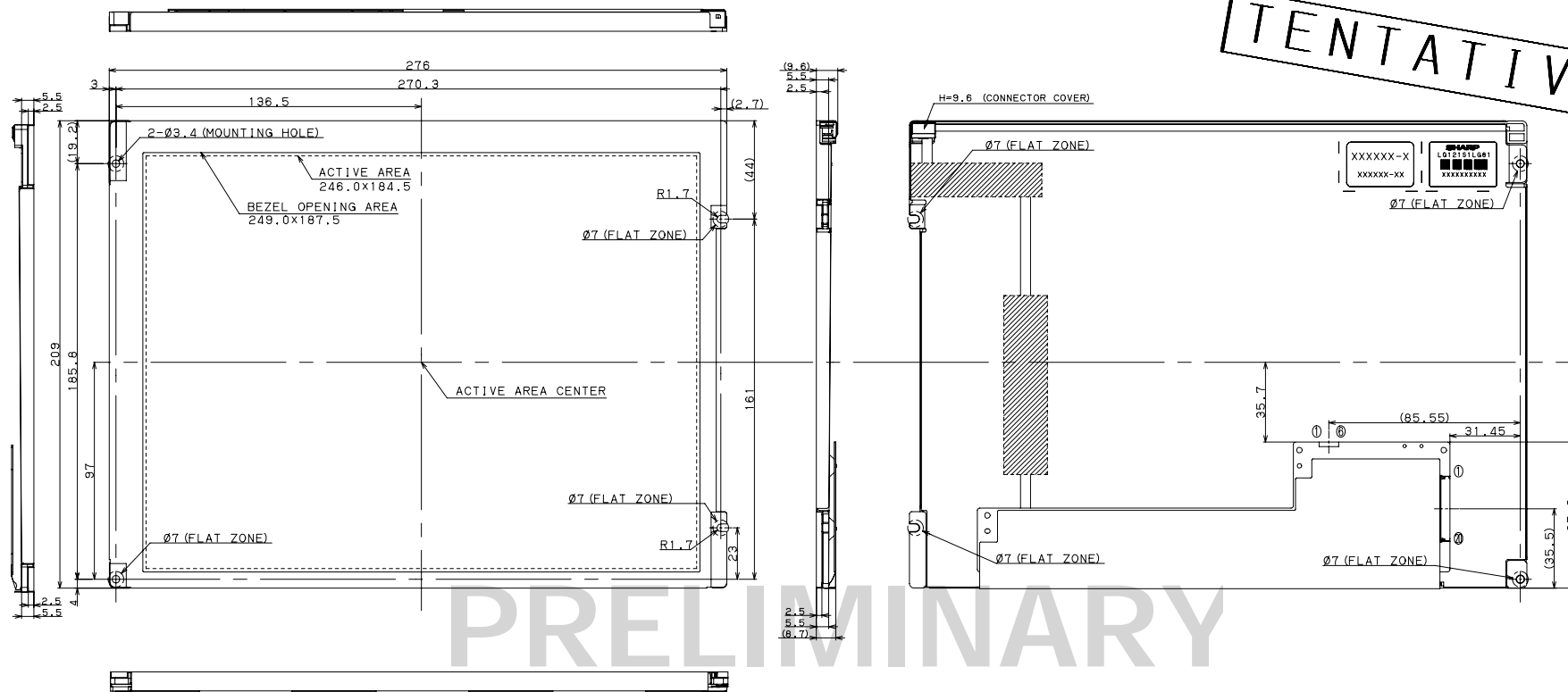

CN1: INTERFACE CONNECTOR PIN LAYOUT

pin	1	2	3	4	5	6	7
	VCC	VCC	GND	GND	RXIN0-	RXIN0+	GND
8	9	10	11	12	13	14	15
RXIN1-	RXIN1+	GND	RXIN2-	RXIN2+	GND	CKIN-	CKIN+
16	17	18	19	20			
GND	R/L	U/D	GND	GND			

CORRESPONDING CONNECTOR: F1-SE20M, F1-S20S

CN2: 【LED BACK LIGHT CONNECTOR】 CN2: SM06B-SHLS-TF

pin	1	2	3	4	5	6
	VDD	VDD	GND	GND	XSTABY	VBR

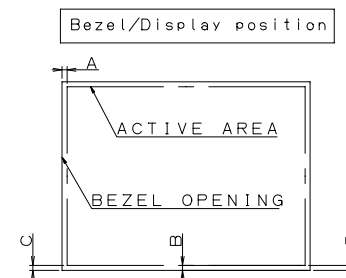

- 1) Tolerance X direction A: 1.8 ± 0.8
- 2) Tolerance Y direction B: 1.8 ± 0.8
- 3) Obliquity of display area $|C-D| < 0.8$

NOTES

- 1) Unspecified tolerance to be ± 0.5
- 2) Warp and flating for PWB cover and FPC are excluded from thickness and dimension of the unit.
- 3) Please do not contact the conductive things to the part of the PWB without the PWB cover.

Fig1: OUTLINE DIMENSIONS (LQ121S1LG81)

LCD Specification

LCD Group



NORTH AMERICA

Sharp Microelectronics of the Americas
5700 NW Pacific Rim Blvd.
Camas, WA 98607, U.S.A.
Phone: (1) 360-834-2500
Fax: (1) 360-834-8903
www.sharpsma.com

TAIWAN

Sharp Electronic Components
(Taiwan) Corporation
8F-A, No. 16, Sec. 4, Nanking E. Rd.
Taipei, Taiwan, Republic of China
Phone: (886) 2-2577-7341
Fax: (886) 2-2577-7326/2-2577-7328

CHINA

Sharp Microelectronics of China
(Shanghai) Co., Ltd.
28 Xin Jin Qiao Road King Tower 16F
Pudong Shanghai, 201206 P.R. China
Phone: (86) 21-5854-7710/21-5834-6056
Fax: (86) 21-5854-4340/21-5834-6057
Head Office:
No. 360, Bashen Road,
Xin Development Bldg. 22
Waigaoqiao Free Trade Zone Shanghai
200131 P.R. China
Email: smc@china.global.sharp.co.jp

EUROPE

Sharp Microelectronics Europe
Division of Sharp Electronics (Europe) GmbH
Sonninstrasse 3
20097 Hamburg, Germany
Phone: (49) 40-2376-2286
Fax: (49) 40-2376-2232
www.sharpsme.com

SINGAPORE

Sharp Electronics (Singapore) PTE., Ltd.
438A, Alexandra Road, #05-01/02
Alexandra Technopark,
Singapore 119967
Phone: (65) 271-3566
Fax: (65) 271-3855

KOREA

Sharp Electronic Components
(Korea) Corporation
RM 501 Geosung B/D, 541
Dohwa-dong, Mapo-ku
Seoul 121-701, Korea
Phone: (82) 2-711-5813 ~ 8
Fax: (82) 2-711-5819

JAPAN

Sharp Corporation
Electronic Components & Devices
22-22 Nagaïke-cho, Abeno-Ku
Osaka 545-8522, Japan
Phone: (81) 6-6621-1221
Fax: (81) 6117-725300/6117-725301
www.sharp-world.com

HONG KONG

Sharp-Roxy (Hong Kong) Ltd.
Level 26, Tower 1, Kowloon Commerce Centre,
No. 51, Kwai Cheong Road, Kwai Chung,
New Territories, Hong Kong
Phone: (852) 28229311
Fax: (852) 28660779
www.sharp.com.hk
Shenzhen Representative Office:
Room 602-603, 6/F,
International Chamber of Commerce Tower,
168 Fuhua Rd. 3, CBD,
Futian District, Shenzhen 518048,
Guangdong, P.R. China
Phone: (86) 755-88313505
Fax: (86) 755-88313515

SPECIFICATIONS ARE SUBJECT TO CHANGE WITHOUT NOTICE.

Suggested applications (if any) are for standard use; See Important Restrictions for limitations on special applications. See Limited Warranty for SHARP's product warranty.

The Limited Warranty is in lieu, and exclusive of, all other warranties, express or implied.

ALL EXPRESS AND IMPLIED WARRANTIES, INCLUDING THE WARRANTIES OF MERCHANTABILITY, FITNESS FOR USE AND FITNESS FOR A PARTICULAR PURPOSE, ARE SPECIFICALLY EXCLUDED. In no event will SHARP be liable, or responsible in any way, for any incidental or consequential economic or property damage.