

# HITACHI

FOR MESSRS: \_\_\_\_\_

DATE: Feb.20,2004

## CUSTOMER'S ACCEPTANCE SPECIFICATIONS SX19V010-ZZA CONTENTS

No.	ITEM	SHEET No.	PAGE
1	COVER	7B64PS 2701-SX19V010-ZZA-3	1-1/1
2	RECORD OF REVISION	7B64PS 2702-SX19V010-ZZA-3	2-1/1
3	MECHANICAL DATA	7B64PS 2703-SX19V010-ZZA-3	3-1/1
4	ABSOLUTE MAXIMUM RATINGS	7B64PS 2704-SX19V010-ZZA-3	4-1/1
5	ELECTRICAL CHARACTERISTICS	7B64PS 2705-SX19V010-ZZA-3	5-1/2~2/2
6	OPTICAL CHARACTERISTICS	7B64PS 2706-SX19V010-ZZA-3	6-1/3~3/3
7	BLOCK DIAGRAM	7B64PS 2707-SX19V010-ZZA-3	7-1/1
8	INTERFACE TIMING CHART	7B64PS 2708-SX19V010-ZZA-3	8-1/5~5/5
9	DIMENSIONAL OUTLINE	7B63PS 2709-SX19V010-ZZA-3	9-1/1
10	APPEARANCE STANDARD	7B64PS 2710-SX19V010-ZZA-3	10-1/4~4/4
11	PRECAUTION FOR USE	7B64PS 2711-SX19V010-ZZA-3	11-1/3~3/3
12	DESIGNATION OF LOT MARK	7B64PS 2712-SX19V010-ZZA-3	12-1/1

\* When product will be discontinued, customer will be informed by HITACHI with twelve months prior announcement.

ACCEPTED BY: \_\_\_\_\_

PROPOSED BY: Jimmy HO

## RECORD OF REVISION

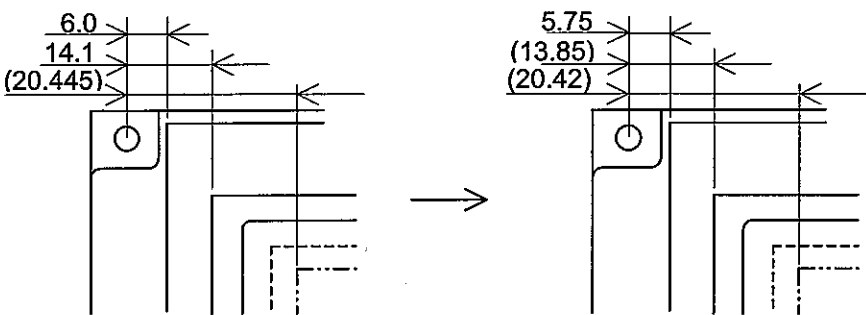
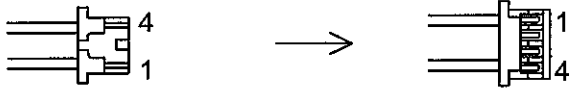
DATE	SHEET No.	SUMMARY
Dec.25,'03	7B64PS2703-SX19V010-ZZA-2 Page 3-1/1	Revised : (6) with glare upper polarizer ↓ with Anti-glare upper polarizer
	7B63PS2709-SX19V010-ZZA-2 Page 9-1/1	Added : 2.5 size at Left-Top side of the LCM. Revised : Cable connector output position.
Feb.20,'04	7B63PS2709-SX19V010-ZZA-3 Page 9-1/1	<p>Revised dimension</p>  <p>Revised CN2 position</p>  <p>Revised CN1 detail dimension tolerance 19.0 ± 0.05 → 19.0 ± 0.1</p>

### 3. MECHANICAL DATA

No.	ITEM	CONTENTS	UNIT
(1)	Module Size	197.0(W) x 145.0(H) x 9.6(D)	mm
(2)	Viewing Area	(158.0)(W) x (118.0)(H)	mm
(3)	Dot Number	640 x3 (R.G.B)(W) x 480(H)	dots
(4)	Dot Size	0.064(W) x 0.222(H)	mm
(5)	Dot Pitch	0.079(W) x 0.237(H)	mm
(6)	LCD Type	<ul style="list-style-type: none"> <li>•Color-STN (Negative type)</li> <li>•with Anti-glare upper polarizer and transmissive rear polarizer.</li> <li>•0.7mm thickness glass</li> </ul>	-
(7)	Contrast Ratio	(25)	-
(8)	Duty	1/484	-
(9)	Viewing Direction	6 O'clock	-
(10)	Operating Temperature	+0 ~ +50	°C
(11)	Storage Temperature	-20 ~ +70	°C
(12)	Backlight	Cold Cathode Fluorescent Lamp(CFL) x 2	pcs
(13)	Power Supply Voltage	3.3V , 36.6V	-
(14)	Weight	(350)	g
(15)	Touch Panel	Resistance type	-

## 4. ABSOLUTE MAXIMUM RATINGS

### 4.1 ELECTRICAL ABSOLUTE MAXIMUM RATINGS (V<sub>SS</sub>=0V)

Item	Symbol	Min.	Max.	Unit
Power Supply for Logic	V <sub>DD</sub> -V <sub>SS</sub>	-0.3	7.0	V
Power Supply for LCD Driver	V <sub>LCD</sub> -V <sub>SS</sub>	0	42.0	V
Input Voltage(Note 1)	V <sub>I</sub>	V <sub>SS</sub> -0.3	V <sub>DD</sub> +0.3	V

Note 1 : FLM , CL1 , CL2 ,  $\overline{DOFF}$  , D0~D7.

Note 2 : Ta=25°C

Note 3 : Please be sure users are grounded when handling LCD module.  
V<sub>SS</sub>=0V

### 4.2 ELECTRICAL ABSOLUTE MAXIMUM RATINGS (TOUCH PANEL)

Item	Specification	Note
Voltage	(7VDC)(Max.)	-
Current	20mA(Max.)	-

### 4.3 ENVIRONMENTAL ABSOLUTE MAXIMUM RATINGS

Item	Operating		Storage		Remark
	MIN.	MAX.	MIN.	MAX.	
Ambient Temperature	0°C	50°C	-20°C	70°C	(Note1,2,3)
Humidity	(Note 4)		(Note 4)		No Condensation
Vibration	-	2.45m/s <sup>2</sup>	-	11.76m/s <sup>2</sup> (Note 5)	1h max. (Note 6)
Shock	-	29.4m/s <sup>2</sup>	-	490m/s <sup>2</sup> (Note 5)	XYZ directions 11ms

Note 1 : Ta at -20°C-----< 48 h , at 70°C-----< 120 h.

Note 2 : Background color changes slightly depending on ambient temperature.  
The phenomenon is reversible.

Note 3 : When LCM is operated at 5°C , the lift time of CFL will be reduced.  
Need to make sure of value of IL and characteristics of inverter.  
The response time at 5°C will be lower.

Note 4 : Ta ≤ 40°C : 85%RH max.

Ta > 40°C : Absolute humidity must be lower than the humidity of 85%RH at 40°C.

Note 5 : The module should be operated normally after the test is finished.

Note 6 : 5Hz ~ 100Hz (Except resonance frequency).

## 5. ELECTRICAL CHARACTERISTICS

### 5.1 ELECTRICAL CHARACTERISTICS OF LCD

Item	Symbol	Condition	Min.	Typ.	Max.	Unit
Power Supply for Logic	V <sub>DD-VSS</sub>	-	3.15	3.3	3.45	V
Power Adjustment Voltage (Note 1)	V <sub>LCD-VSS</sub>	Ta= 5°C , ϕ=0°	-	-	40	V
		Ta=25°C , ϕ=0°	35.1	36.6	38.1	V
		Ta=40°C , ϕ=0°	32	-	-	V
Input Signal Voltage (Note 2)	V <sub>IH</sub>	"H" Level	0.8V <sub>DD</sub>	-	V <sub>DD</sub>	V
	V <sub>IL</sub>	"L" Level	0	-	0.2V <sub>DD</sub>	
Power supply current (Logic) (Note 3)	I <sub>DD</sub>	V <sub>DD</sub> =3.3V	-	14	30	mA
Power Supply Current (LCD driver) (Note 3)	I <sub>LCD</sub>	V <sub>DD</sub> =3.3V	-	21	50	mA
Frame Frequency (Note 4)	f <sub>FLM</sub>	-	-	(100)	(120)	Hz

Note 1 : In proportion as the V<sub>LCD</sub> decrease the brightness will increase.

The value is specified as the voltage at which the optimum contrast is obtained.

Note 2 : FLM , CL1 , CL2 , DOFF , D0~D7.

Note 3 : f<sub>FLM</sub>=(100)Hz , Ta=25°C , Display pattern is Black/White cross pattern as below.

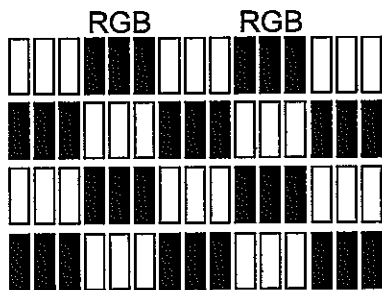

Note 4 : Need to make sure that there is no flicker and ripple phenomenon when setting the Frame Frequency in your set.

### 5.2 ELECTRICAL CHARACTERISTICS OF BACKLIGHT

Item	Symbol	Min.	Typ.	Max.	Unit	Remark
Starting Voltage	V <sub>S</sub>	850	-	1500	V <sub>rms</sub>	Ta=25°C
Lamp Voltage	V <sub>L</sub>	-	443	-	V <sub>rms</sub>	Ta=25°C
Frequency	f <sub>L</sub>	40	60	80	kHz	Ta=25°C
Lamp Current	I <sub>L</sub>	3.5	4.0	4.5	mArms	Ta=25°C
CFL life time	-	10000	20000	-	Hour	Ta=25°C I <sub>L</sub> =4.0mA

Note 1 : Starting voltage is higher when LCM at lower temperature.

Note 2 : Average life time of CFL will be decreased when LCM is operated at lower temperature

### 5.3 ELECTRICAL CHARACTERISTICS OF TOUCH PANEL

#### 5.3.1 Operating Condition

ITEM	SPECIFICATION	NOTE
Operating Voltage	5VDC	-
Operating Current	20mA	-

#### 5.3.2 Electrical Characteristics

ITEM		SPECIFICATION	NOTE
Circuit Resistance	X-axis	(200Ω~900Ω)	at connector
	Y-axis	(200Ω~900Ω)	at connector
Circuit Resistance Rate	X-axis	10% max.	at connector
	Y-axis	10% max.	at connector
Insulation Resistance	X-Y	20MΩ min.	at DC 25V
Linearity	X	1.5% max.	(note 1)
	Y	1.5% max.	
Chattering		15ms max.	-

#### 5.3.3 Mechanical Characteristics

ITEM	SPECIFICATION	NOTE
Activation Force	(40g~100g)	-
Hardness of Surface	(3H)	JIS K 5400

#### 5.3.4 Optical Characteristics

ITEM	SPECIFICATION	NOTE
Transparency	(80% typ.)	-

Note 1 : Test method and condition of linearity

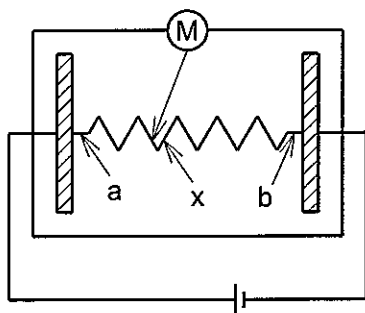

Linearity Definition

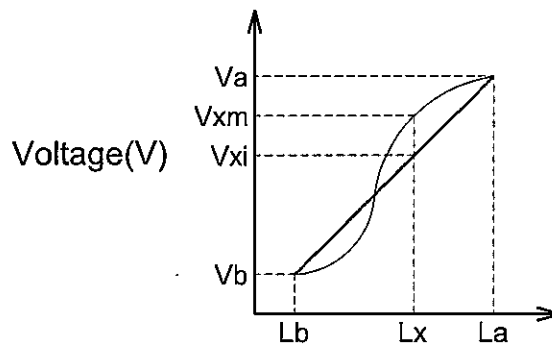

Linearity Definition

Va : Maximum voltage in the active area of Touch Panel

Vb : Minimum voltage in the active area of Touch Panel

X : Random measuring point

Vxm : Actual voltage of Lx point

Vxi : Theoretical voltage of Lx point

$$\text{Linearity} : [ | Vxi - Vxm | / (Va - Vb) \times 100\% ]$$

# 6. OPTICAL CHARACTERISTICS

## 6.1 OPTICAL CHARACTERISTICS OF LCD

Ta=25 °C (Backlight on)

Item	Symbol	Condition	Min.	Typ.	Max.	Unit	Remark	
Viewing Area Range	$\phi 1, \phi 2$	$CR \geq 2$	X axle	-	60	-	Deg	Note 1,2
			Y axle	-	35	-		
Contrast Ratio	CR	$\phi = 0^\circ$	-	(25)	-	-	Note 3,4	
Response Time	Rise	tr	$\theta = 0^\circ, \phi = 0^\circ$	-	(340)	-	ms	Note 5
	Fall	tf	$\theta = 0^\circ, \phi = 0^\circ$	-	(100)	-	ms	
Color Tone (CIE Coordinate)	R	x	$\theta = 0^\circ, \phi = 0^\circ$	(0.44)	(0.49)	(0.54)	-	
		y		(0.30)	(0.35)	(0.40)	-	
	G	x		(0.28)	(0.33)	(0.38)	-	
		y		(0.44)	(0.49)	(0.54)	-	
	B	x		(0.15)	(0.20)	(0.25)	-	
		y		(0.16)	(0.21)	(0.26)	-	
	W	x		(0.27)	(0.32)	(0.37)	-	
		y		(0.30)	(0.35)	(0.40)	-	

Note 1 : Definition of  $\theta$  and  $\phi$

Note 2 : Definition of viewing angle  $\phi 1$  and  $\phi 2$

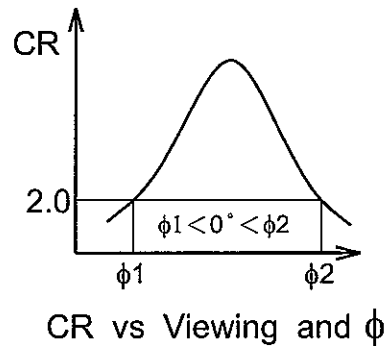
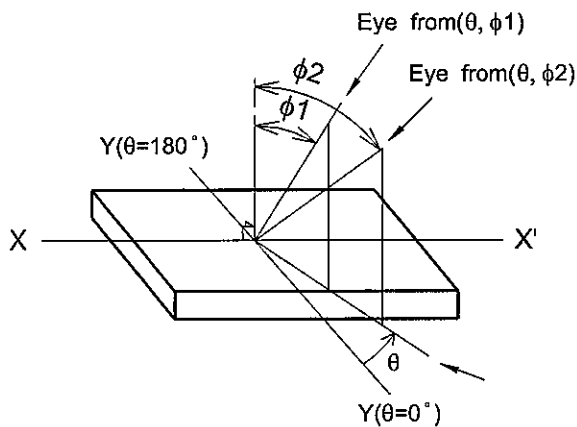

Note 3 : Definition of contrast ratio "CR"

$$CR = \frac{\text{Brightness on selected dot (B1)}}{\text{Brightness on non-selected dot (B2)}}$$

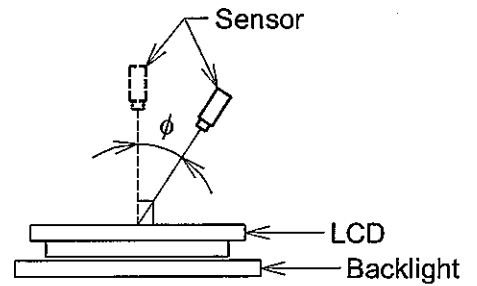
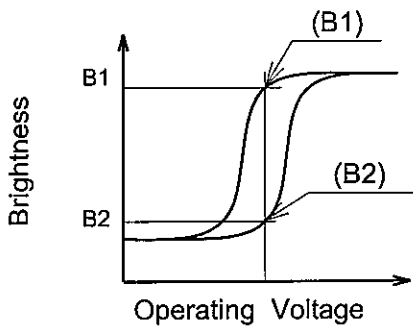

Sensor : BM-7  
Aperture : 1°  
Distance : 50cm

Note 4 : Definition of "CR" and "V<sub>OP</sub>"

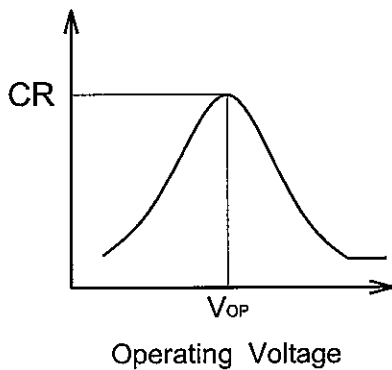

Note 5 : Definition of optical response time

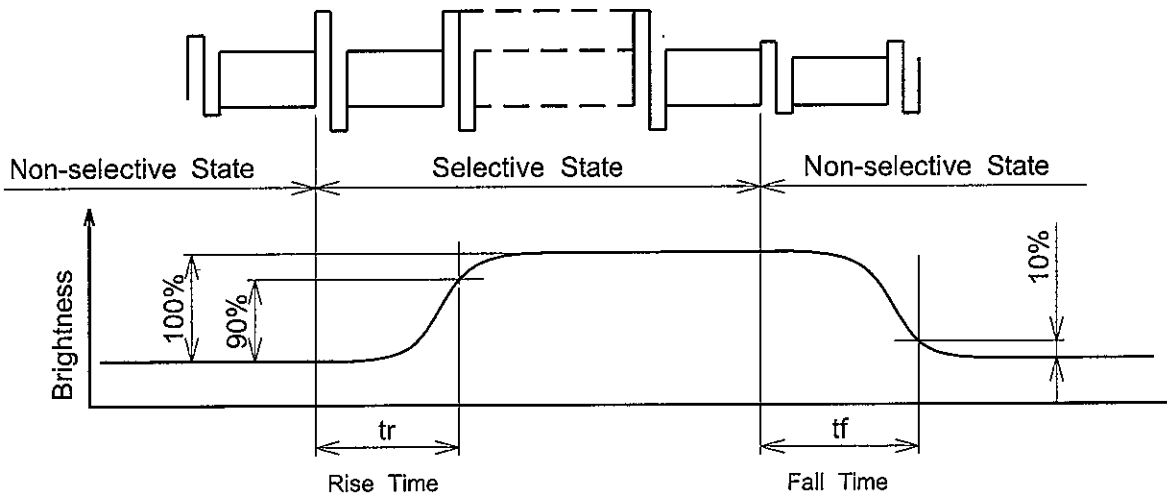



## 6.2 OPTICAL CHARACTERISTICS OF BACKLIGHT

Item	Min.	Typ.	Max.	Unit	Remark
Brightness	-	(120)	-	cd/m <sup>2</sup>	(Note 1,2,3)
Brightness Uniformity	-	-	±30	%	(Note 2,3,4)

Note 1 : Measurement Condition :

- Display data should be all "ON" (D0~D7=HIGH).
- V<sub>LCD</sub> should be adjusted at the voltage where the peak contrast is obtained.
- Start measuring after CFL working 30 minutes.

Note 2 : Measurement of the following 5 points on the display.

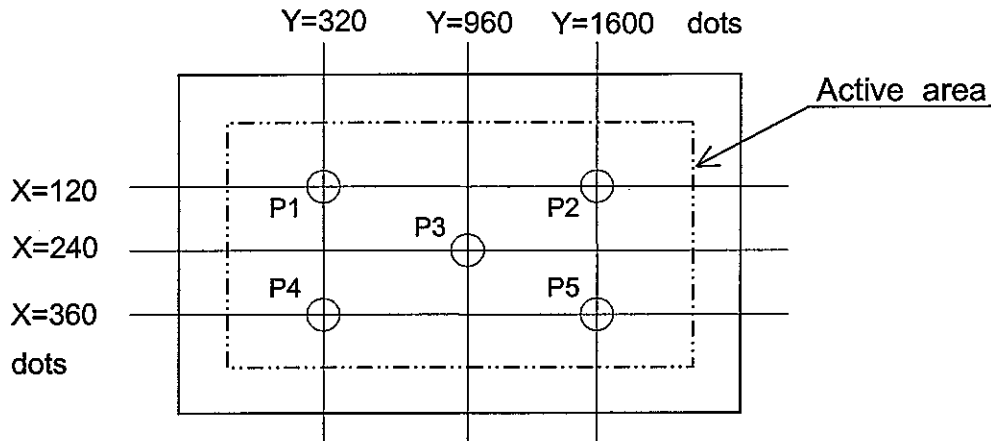

Note 3 : The brightness should be the average of P1~P5 point.

Note 4 : Definition of the brightness uniformity

$$\left( \frac{\text{Max. brightness or Min. brightness} - \text{Average brightness}}{\text{Average brightness}} \right) \times 100$$

# 7. BLOCK DIAGRAM

CN1

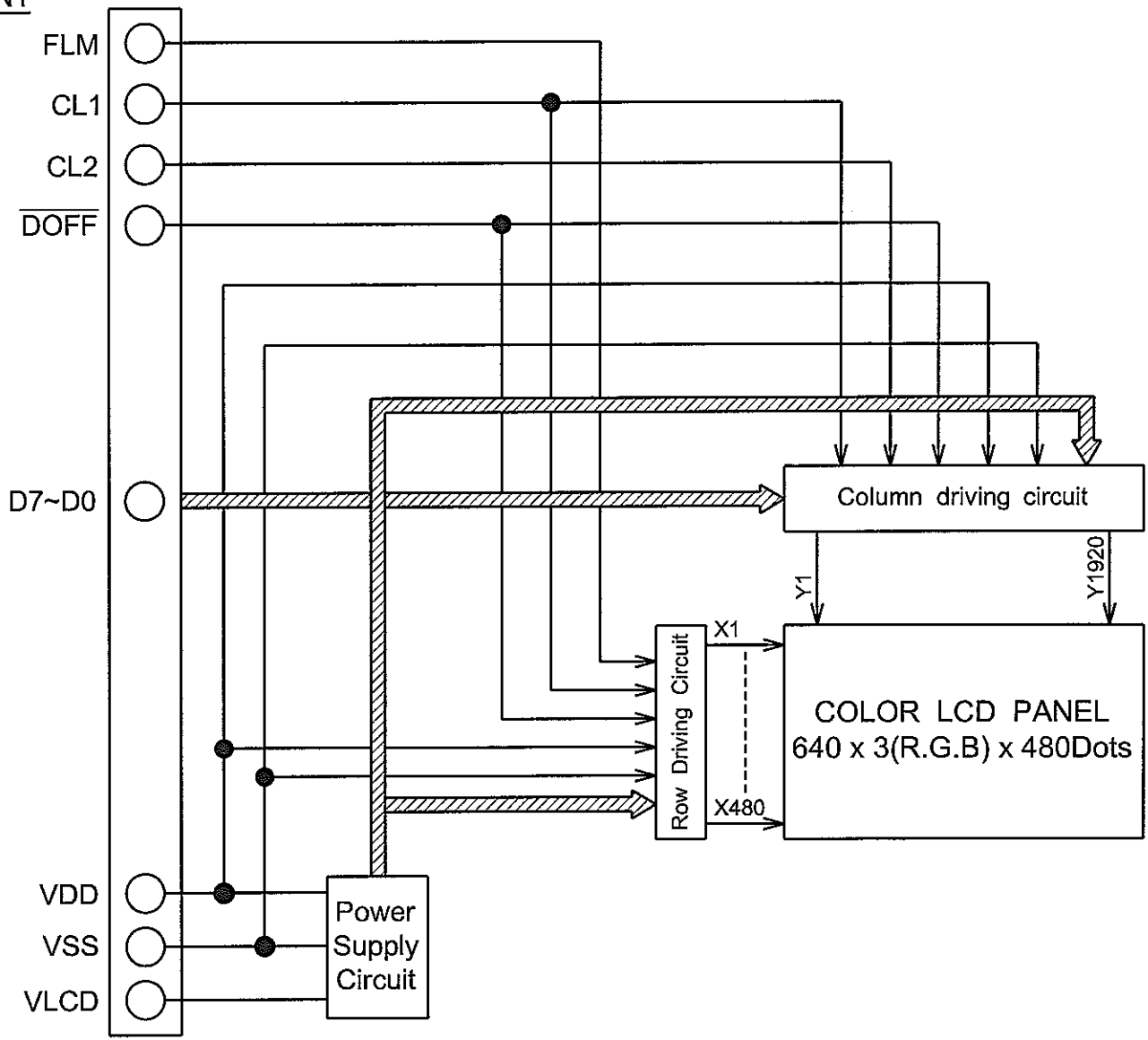

CN2

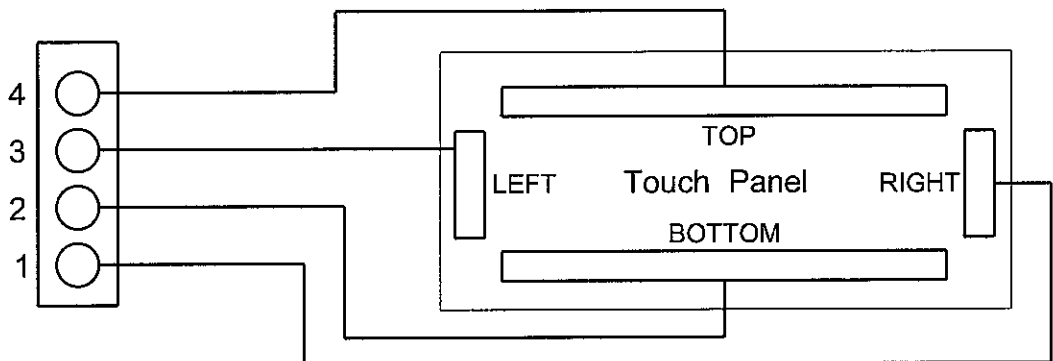

CN3

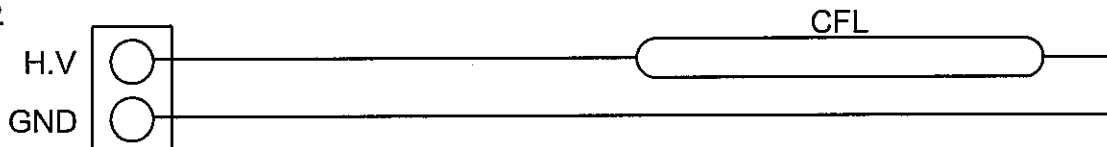

CN4

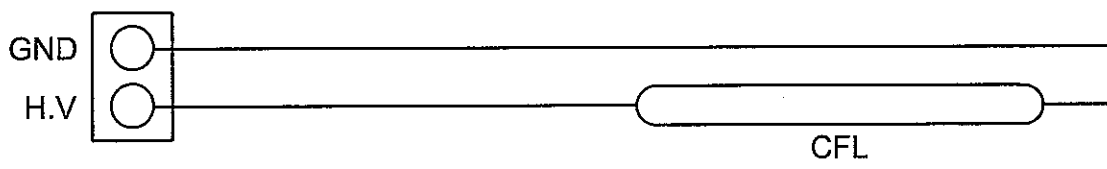

# 8. INTERFACE TIMING CHART

## 8.1 TIMING CHART

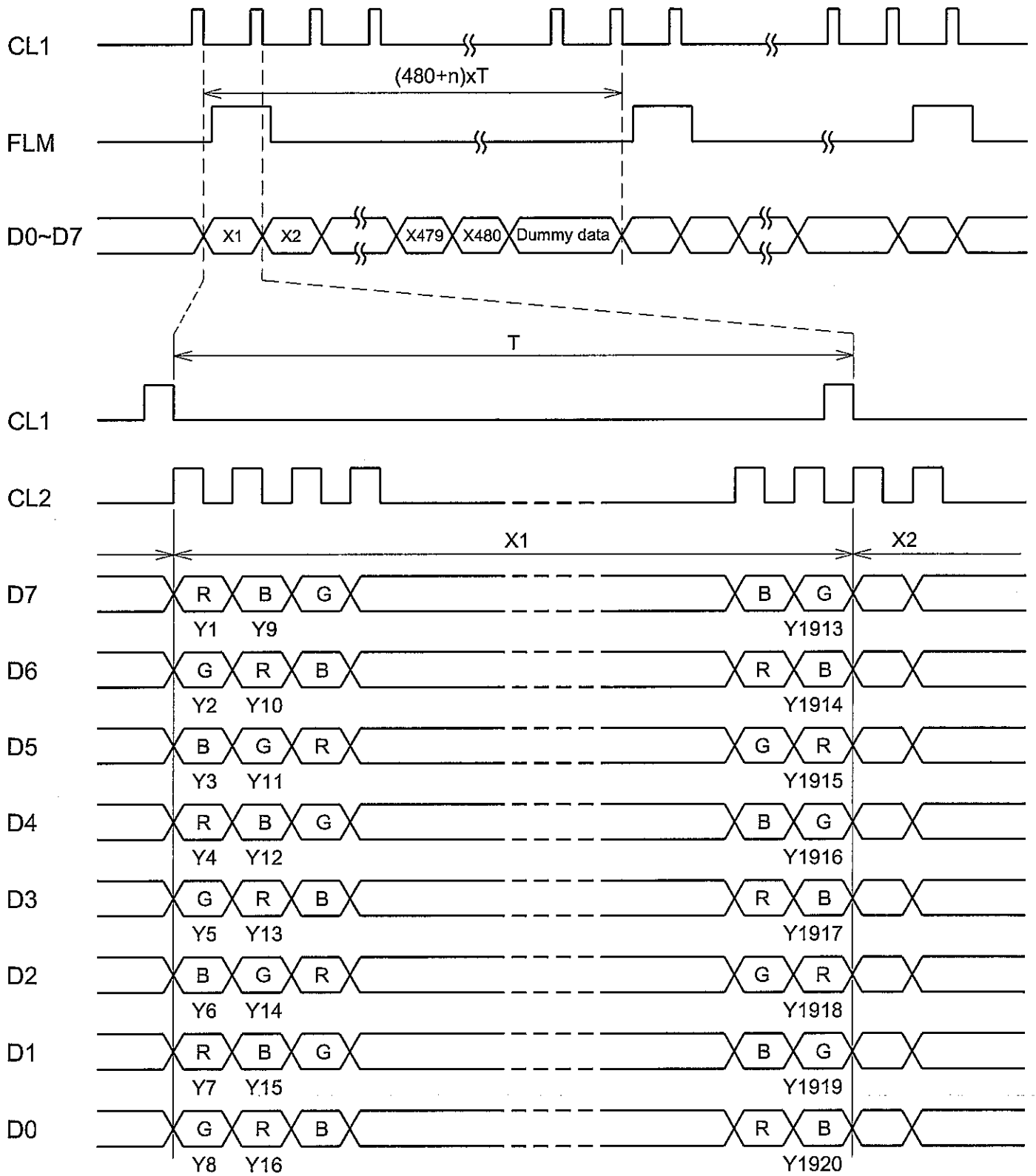

## 8.2 ELECICAL CHARACTERISTICS

( $V_{DD}=3.0\sim 4.5V$ ,  $V_{LCD}=10.0\sim 42.0V$ ,  $T_a=0^{\circ}C \sim 40^{\circ}C$ )

Item	Symbol	Min.	Typ.	Max.	Unit
Shift clock period	tWCK	66	-	-	ns
Shift clock "H" pulse wide	tWCKH	23	-	-	ns
Shift clock "L" pulse wide	tWCKL	23	-	-	ns
Data setup time	tDS	10	-	-	ns
Data hold time	tDH	25	-	-	ns
Latch pulse "H" pulse wide	tWLPH	30	-	-	ns
Shift clock rise to latch pulse rise time	tLD	10	-	-	ns
Shift clock fall to latch pulse fall time	tSL	30	-	-	ns
Latch pulse rise to shift clock rise time	tLS	30	-	-	ns
Latch pulse fall to shift clock fall time	tLH	30	-	-	ns
Enable setup time	tTS	12	-	-	ns
Input signal rise time	tR	-	-	50	ns
Input signal fall time	tF	-	-	50	ns
Output delay	tD	-	-	44	ns
FLM setup time	tFS	30	-	-	ns
FLM hold time	tFH	50	-	-	ns

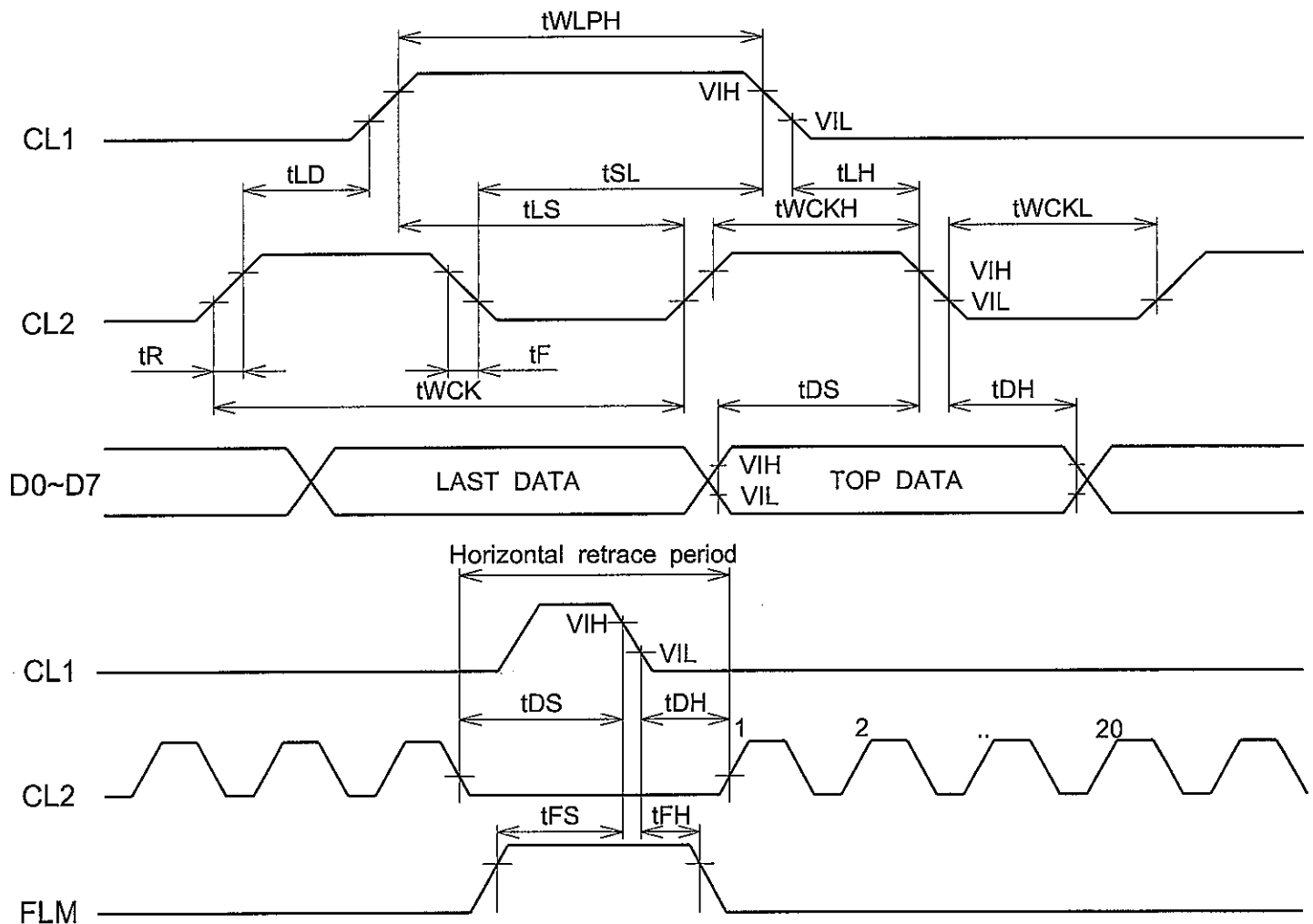

### 8.3 POWER SUPPLY AND SIGNAL SEQUENCE

Do not apply DC voltage to the LCD panel because that induces the electrochemical reaction and reduces its life time. Please follow the power supply ON/OFF sequence to prevent DC driving of LCD or latch-up of COMS LSI , as shown below.

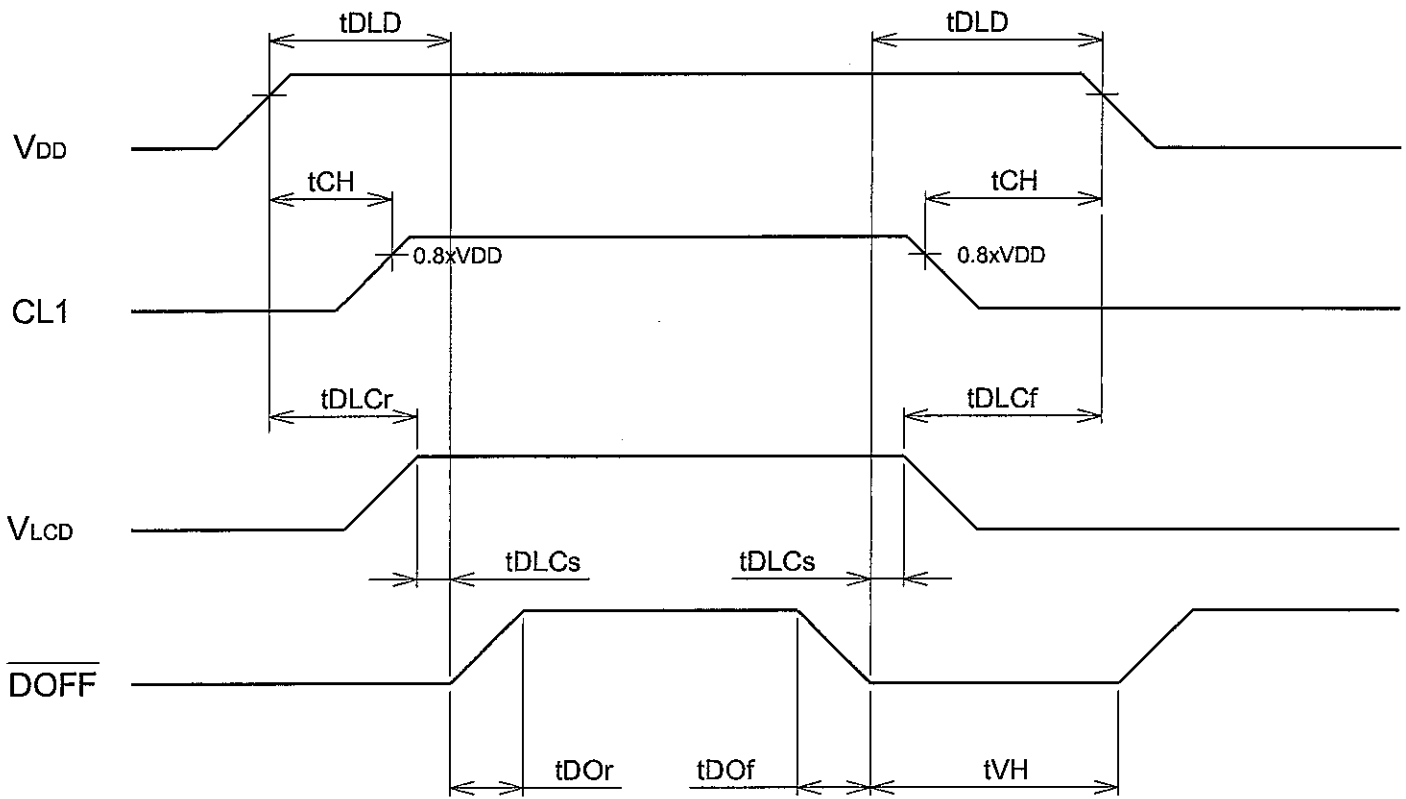

POWER ON

POWER OFF

Symbol	Min.	Max.	Unit	Comment
tDLD	200	—	ms	
tCH	0	—	ms	
tDOr	—	100	ns	
tDOF	—	100	ns	
tDLCr	20	—	ms	
tDLCf	20	—	ms	
tDLCs	20	—	ms	
tVH	200	—	ms	

Note 1 : Please keep the specified sequence because wrong sequence may cause permanent damage to the LCD panel.

Note 2 : Please use  $\overline{\text{DOFF}}$  function. Switching by other than the  $\overline{\text{DOFF}}$  function may cause display deterioration.

Note 3 : VLCD voltage should be set up to adjusted voltage before  $\overline{\text{DOFF}}$  signal arises. Otherwise, when  $\overline{\text{DOFF}}$  signal arises, adjusted contrast image may not be generated.

Note 4 : Please keep the specified sequence of  $\overline{\text{DOFF}}$  signal because if the tVH is short enough, LCD panel may not be restarted.

### 8.4 INPUT DATA ALLOCATION TABLE

Data Signal	D 7	D 6	D 5	D 4	D 3	D 2	D 1	D 0	D 7	D 6	D 5	D 4	-----	D 4	D 3	D 2	D 1	D 0
Y X	1	2	3	4	5	6	7	8	9	10	11	12	-----	1 9 1 6	1 9 1 7	1 9 1 8	1 9 1 9	1 9 2 0
1	R	G	B	R	G	B	R	G	B	R	G	B	-----	G	B	R	G	B
2	R	G	B	R	G	B	R	G	B	R	G	B	-----	G	B	R	G	B
3	R	G	B	R	G	B	R	G	B	R	G	B	-----	G	B	R	G	B
4	R	G	B	R	G	B	R	G	B	R	G	B	-----	G	B	R	G	B
5	R	G	B	R	G	B	R	G	B	R	G	B	-----	G	B	R	G	B
6	R	G	B	R	G	B	R	G	B	R	G	B	-----	G	B	R	G	B
7	R	G	B	R	G	B	R	G	B	R	G	B	-----	G	B	R	G	B
8	R	G	B	R	G	B	R	G	B	R	G	B	-----	G	B	R	G	B
9	R	G	B	R	G	B	R	G	B	R	G	B	-----	G	B	R	G	B
10	R	G	B	R	G	B	R	G	B	R	G	B	-----	G	B	R	G	B
---	---	---	---	---	---	---	---	---	---	---	---	---	-----	---	---	---	---	---
478	R	G	B	R	G	B	R	G	B	R	G	B	-----	G	B	R	G	B
479	R	G	B	R	G	B	R	G	B	R	G	B	-----	G	B	R	G	B
480	R	G	B	R	G	B	R	G	B	R	G	B	-----	G	B	R	G	B

R : RED  
 G : GREEN  
 B : BLUE

## 8.5 INTERFACE PIN CONNECTION

CN1 : FFC : Pitch 1.0mm/Suitable Connector : 52207-2090(MOLEX)

PIN NO.	SIGNAL	PIN FUNCTION
1	FLM	Scan Start-up Signal
2	V <sub>ss</sub>	GND
3	CL1	Input Data Latch Signal
4	V <sub>ss</sub>	GND
5	CL2	Data Shift Clock
6	V <sub>ss</sub>	GND
7	D0	Display Data
8	D1	Display Data
9	D2	Display Data
10	D3	Display Data
11	D4	Display Data
12	D5	Display Data
13	D6	Display Data
14	D7	Display Data
15	$\overline{\text{DOFF}}$	Display Control Signal H : ON , L : OFF
16	V <sub>DD</sub>	Logic Supply Voltage
17	V <sub>DD</sub>	Logic Supply Voltage
18	V <sub>ss</sub>	GND
19	V <sub>LCD</sub>	Power Supply for LCD
20	V <sub>ss</sub>	GND

CN2 : FPC : Pitch 1.0mm/Suitable Connector : 52271-0490(MOLEX)

PIN No.	SIGNAL	PIN FUNCTION
1	-	Touch Panel RIGHT
2	-	Touch Panel BOTTOM
3	-	Touch Panel LEFT
4	-	Touch Panel TOP

CN3, CN4 : M63-M83-04(MITSUMI)

/Suitable connector : M61-M73-04(MITSUMI)<inter connector type>

M60-04-30-114P(MITSUMI)<srtaight type>

M60-04-30-134P(MITSUMI)<angle type>

PIN No.	SIGNAL	PIN FUNCTION
1	H.V	Power Supply Voltage for CFL
2	N.C	-----
3	N.C	-----
4	GND	CFL GND

9. OUTLINE DIMENSION

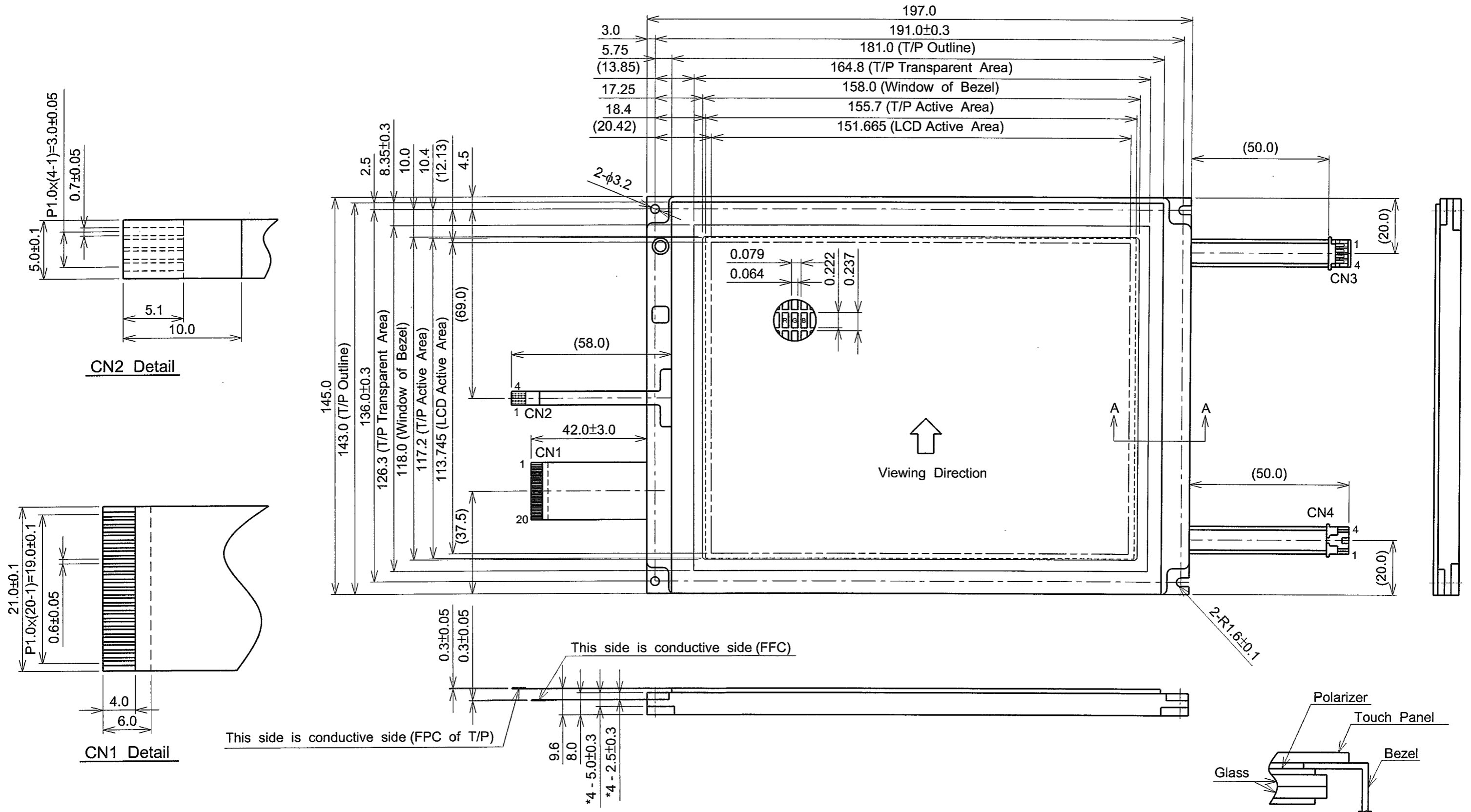

- CN1 : FFC Pitch 1.0mm  
Suitable Connector 52207-2090(MOLEX)
- CN2 : Touch Panel FPC Pitch 1.0mm  
Suitable Connector 52271-0490(MOLEX)
- CN3, CN4 : M63-M83-04(MITSUMI)  
PIN-1: H.V ; PIN-4:GND

Note 1 : All dimensional tolerance unless otherwise specified  $\pm 0.5$   
 Note 2 : Scale : NTS , Unit : mm



## 10. APPEARANCE STANDARD

### 10.1 APPEARANCE INSPECTION

Appearance inspection should be done under the following condition.

- (1) In the dark room. The CFL should be lighted with the prescribed inverter.
- (2) The distance from eyes to LCD must be 25 cm.
- (3) Viewing direction must be within 25 degree to vertical line of LCD center.

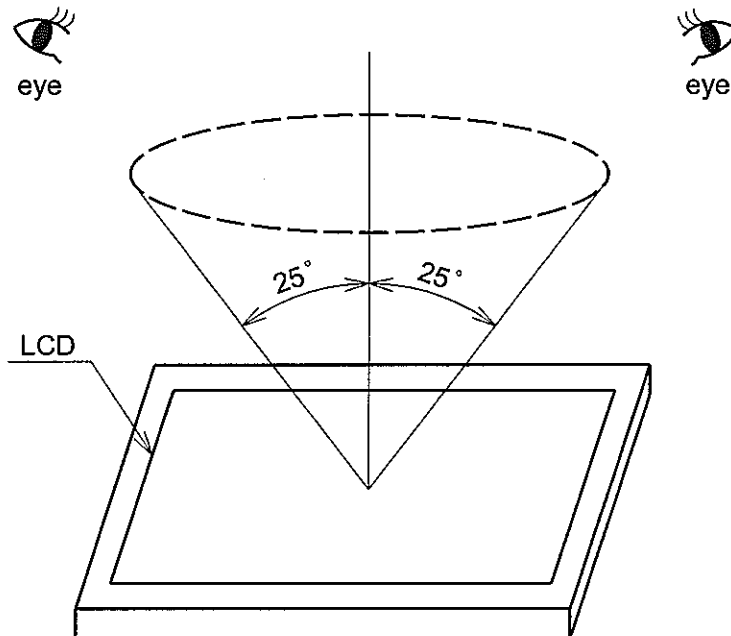

### 10.2 DEFINITION OF A ZONE , B ZONE

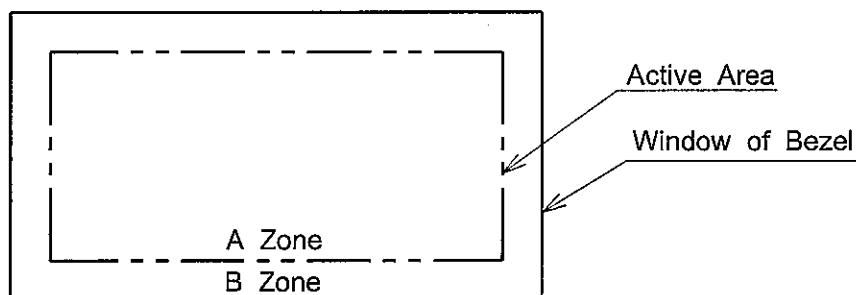

### 10.3 APPEARANCE CRITERION

Customer and supplier should hold a discussion when there is any problem about standard quality assurance or special quality assurance is needed.

Inspection Standard : MIL-STD-105E normal inspection level II

#### (1) LCD Appearance

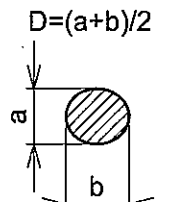
No.	ITEM	CRITERION	Zone	AQL																																						
1	Stains Scratches Black Spots White Spots Foreign Particles	<p>Line Shape :</p> <table border="1"> <thead> <tr> <th>Length</th> <th>Width</th> <th>Acceptable Q'ty</th> </tr> </thead> <tbody> <tr> <td><math>L \leq 2.0</math></td> <td><math>W \leq 0.03</math></td> <td>Disregard</td> </tr> <tr> <td><math>L \leq 3.0</math></td> <td><math>0.03 &lt; W \leq 0.05</math></td> <td>6</td> </tr> <tr> <td><math>L \leq 2.5</math></td> <td><math>0.05 &lt; W \leq 0.1</math></td> <td>1</td> </tr> <tr> <td>-</td> <td><math>0.1 &lt; W</math></td> <td>As round shape</td> </tr> </tbody> </table>  <p>Round Shape :</p> <table border="1"> <thead> <tr> <th>Diameter</th> <th>Acceptable Q'ty</th> <th>Minimum Space</th> </tr> </thead> <tbody> <tr> <td><math>D \leq 0.2</math></td> <td>Disregard</td> <td>-</td> </tr> <tr> <td><math>0.2 &lt; D \leq 0.3</math></td> <td>10</td> <td>10 mm</td> </tr> <tr> <td><math>0.3 &lt; D \leq 0.4</math></td> <td>5</td> <td>30 mm</td> </tr> <tr> <td><math>0.4 &lt; D</math></td> <td>0</td> <td>-</td> </tr> </tbody> </table>  <p>The total number of "Line" + "Round" is 10 max. Any defect wiped out easily is acceptable.</p>	Length	Width	Acceptable Q'ty	$L \leq 2.0$	$W \leq 0.03$	Disregard	$L \leq 3.0$	$0.03 < W \leq 0.05$	6	$L \leq 2.5$	$0.05 < W \leq 0.1$	1	-	$0.1 < W$	As round shape	Diameter	Acceptable Q'ty	Minimum Space	$D \leq 0.2$	Disregard	-	$0.2 < D \leq 0.3$	10	10 mm	$0.3 < D \leq 0.4$	5	30 mm	$0.4 < D$	0	-	A,B	2.5								
Length	Width	Acceptable Q'ty																																								
$L \leq 2.0$	$W \leq 0.03$	Disregard																																								
$L \leq 3.0$	$0.03 < W \leq 0.05$	6																																								
$L \leq 2.5$	$0.05 < W \leq 0.1$	1																																								
-	$0.1 < W$	As round shape																																								
Diameter	Acceptable Q'ty	Minimum Space																																								
$D \leq 0.2$	Disregard	-																																								
$0.2 < D \leq 0.3$	10	10 mm																																								
$0.3 < D \leq 0.4$	5	30 mm																																								
$0.4 < D$	0	-																																								
2	Bubbles	<table border="1"> <thead> <tr> <th>Diameter</th> <th>Acceptable Q'ty</th> </tr> </thead> <tbody> <tr> <td><math>D \leq 0.2</math></td> <td>Disregard</td> </tr> <tr> <td><math>0.2 &lt; D \leq 0.3</math></td> <td>12</td> </tr> <tr> <td><math>0.3 &lt; D \leq 0.5</math></td> <td>3</td> </tr> <tr> <td><math>0.5 &lt; D</math></td> <td>0</td> </tr> </tbody> </table>	Diameter	Acceptable Q'ty	$D \leq 0.2$	Disregard	$0.2 < D \leq 0.3$	12	$0.3 < D \leq 0.5$	3	$0.5 < D$	0	A,B	2.5																												
Diameter	Acceptable Q'ty																																									
$D \leq 0.2$	Disregard																																									
$0.2 < D \leq 0.3$	12																																									
$0.3 < D \leq 0.5$	3																																									
$0.5 < D$	0																																									
3	Display Quality	<ul style="list-style-type: none"> <li>Viewing angle defect.</li> <li>Missing dots or missing lines.</li> <li>Malfunction.</li> <li>Contrast ratio defect.</li> <li>Power consumption exceeds specification.</li> </ul>	A	0.65																																						
4	Color Tone Color Uniformity	To be judged by HITACHI Display Corporation	A	2.5																																						
5	Contrast Irregularity	<p>(1) Spot (Peak Contrast)</p> <table border="1"> <thead> <tr> <th>Diameter</th> <th>Acceptable Q'ty</th> <th>Minimum Space</th> </tr> </thead> <tbody> <tr> <td><math>D \leq 0.25</math></td> <td>Ignored</td> <td>-</td> </tr> <tr> <td><math>0.25 &lt; D \leq 0.35</math></td> <td>10</td> <td>20 mm</td> </tr> <tr> <td><math>0.35 &lt; D \leq 0.5</math></td> <td>4</td> <td>20 mm</td> </tr> <tr> <td><math>0.5 &lt; D \leq 0.7</math></td> <td>3</td> <td>50 mm</td> </tr> <tr> <td><math>0.7 &lt; D</math></td> <td>0</td> <td>-</td> </tr> </tbody> </table> <p>(2) Line (Peak contrast)</p> <table border="1"> <thead> <tr> <th>Width</th> <th>Length</th> <th>Acceptable Q'ty</th> <th>Minimum Space</th> </tr> </thead> <tbody> <tr> <td><math>W \leq 0.10</math></td> <td><math>L \leq 3.0</math></td> <td>4</td> <td>20 mm</td> </tr> <tr> <td><math>W \leq 0.15</math></td> <td><math>L \leq 2.0</math></td> <td>3</td> <td>20 mm</td> </tr> <tr> <td><math>W \leq 0.20</math></td> <td><math>L \leq 1.5</math></td> <td>3</td> <td>20 mm</td> </tr> <tr> <td><math>W \leq 0.25</math></td> <td><math>L \leq 1.2</math></td> <td>2</td> <td>20 mm</td> </tr> </tbody> </table> <p>(1)+(2) The total number of "Spot"+"Line" is 8 max.</p>	Diameter	Acceptable Q'ty	Minimum Space	$D \leq 0.25$	Ignored	-	$0.25 < D \leq 0.35$	10	20 mm	$0.35 < D \leq 0.5$	4	20 mm	$0.5 < D \leq 0.7$	3	50 mm	$0.7 < D$	0	-	Width	Length	Acceptable Q'ty	Minimum Space	$W \leq 0.10$	$L \leq 3.0$	4	20 mm	$W \leq 0.15$	$L \leq 2.0$	3	20 mm	$W \leq 0.20$	$L \leq 1.5$	3	20 mm	$W \leq 0.25$	$L \leq 1.2$	2	20 mm	A	2.5
Diameter	Acceptable Q'ty	Minimum Space																																								
$D \leq 0.25$	Ignored	-																																								
$0.25 < D \leq 0.35$	10	20 mm																																								
$0.35 < D \leq 0.5$	4	20 mm																																								
$0.5 < D \leq 0.7$	3	50 mm																																								
$0.7 < D$	0	-																																								
Width	Length	Acceptable Q'ty	Minimum Space																																							
$W \leq 0.10$	$L \leq 3.0$	4	20 mm																																							
$W \leq 0.15$	$L \leq 2.0$	3	20 mm																																							
$W \leq 0.20$	$L \leq 1.5$	3	20 mm																																							
$W \leq 0.25$	$L \leq 1.2$	2	20 mm																																							

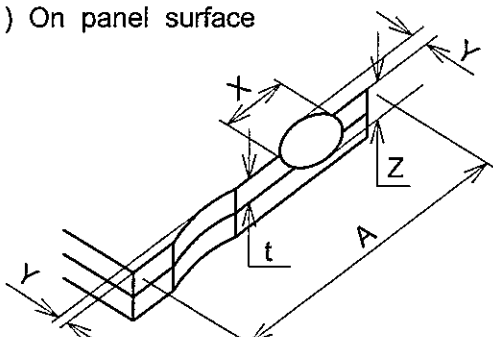
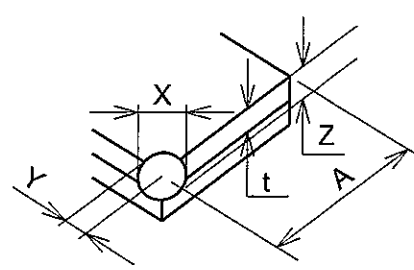
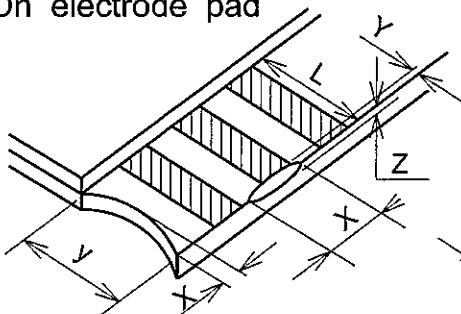
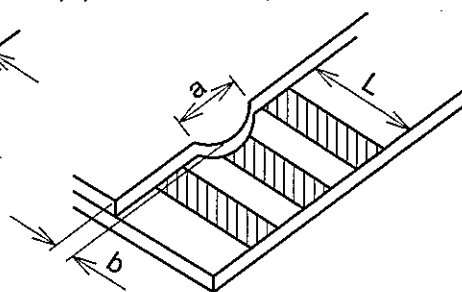
No.	ITEM	CRITERION	AQL																								
6	Chips (LCD Panel)	(1) On panel surface 	2.5																								
		(2) On corner 																									
		<table border="1"> <thead> <tr> <th>Z</th> <th>Y</th> <th>X</th> </tr> </thead> <tbody> <tr> <td><math>Z \leq 1/2t</math></td> <td>Not over viewing area</td> <td><math>X \leq 1/8A</math></td> </tr> <tr> <td><math>1/2t &lt; Z \leq 2t</math></td> <td>Not exceed 1/3S</td> <td><math>X \leq 1/8A</math></td> </tr> </tbody> </table> <p>S : Seal area, X is total length if there are 2 or more chips.</p>		Z	Y	X	$Z \leq 1/2t$	Not over viewing area	$X \leq 1/8A$	$1/2t < Z \leq 2t$	Not exceed 1/3S	$X \leq 1/8A$															
		Z		Y	X																						
$Z \leq 1/2t$	Not over viewing area	$X \leq 1/8A$																									
$1/2t < Z \leq 2t$	Not exceed 1/3S	$X \leq 1/8A$																									
(3) On electrode pad 																											
(4) Substrate protuberance 																											
		<table border="1"> <thead> <tr> <th>Y</th> <th>y</th> <th>X</th> <th>Z</th> </tr> </thead> <tbody> <tr> <td><math>Y \leq 0.5</math></td> <td><math>y \leq L</math></td> <td><math>X \leq 1/8A</math></td> <td><math>0 &lt; Z \leq t</math></td> </tr> </tbody> </table> <p>On rear side of electrode pad</p> <table border="1"> <thead> <tr> <th>Y</th> <th>y</th> <th>X</th> <th>Z</th> </tr> </thead> <tbody> <tr> <td><math>Y \leq 1.0</math></td> <td><math>y \leq L</math></td> <td><math>X \leq 1/8A</math></td> <td><math>t/2 &lt; Z \leq t</math></td> </tr> <tr> <td><math>Y \leq 2.0</math></td> <td><math>y \leq L</math></td> <td><math>X \leq 1/8A</math></td> <td><math>0 &lt; Z \leq t/2</math></td> </tr> </tbody> </table> <table border="1"> <thead> <tr> <th>a</th> <th>b</th> </tr> </thead> <tbody> <tr> <td><math>a \leq A</math></td> <td><math>b \leq 1/3L</math></td> </tr> </tbody> </table>	Y	y	X	Z	$Y \leq 0.5$	$y \leq L$	$X \leq 1/8A$	$0 < Z \leq t$	Y	y	X	Z	$Y \leq 1.0$	$y \leq L$	$X \leq 1/8A$	$t/2 < Z \leq t$	$Y \leq 2.0$	$y \leq L$	$X \leq 1/8A$	$0 < Z \leq t/2$	a	b	$a \leq A$	$b \leq 1/3L$	
Y	y	X	Z																								
$Y \leq 0.5$	$y \leq L$	$X \leq 1/8A$	$0 < Z \leq t$																								
Y	y	X	Z																								
$Y \leq 1.0$	$y \leq L$	$X \leq 1/8A$	$t/2 < Z \leq t$																								
$Y \leq 2.0$	$y \leq L$	$X \leq 1/8A$	$0 < Z \leq t/2$																								
a	b																										
$a \leq A$	$b \leq 1/3L$																										
		Extensive crack is not acceptable.																									

(2) CFL Backlight Appearance

No.	ITEM	CRITERION	Zone	AQL		
1	Dark Spots White Spots Foreign Material (Spot)	Average Diameter D(mm)	A	2.5		
		$D \leq 0.4$			Maximum Acceptable Number Ignored	
		$0.4 < D$			None	
2	Foreign Materials(Line)	Width W(mm)	A	2.5		
		$W \leq 0.2$			Length L(mm)	Maximum Acceptable Number 1
		$0.2 < W$			$L \leq 2.5$	None
3	Scratches	Width W(mm)	A	2.5		
		$W \leq 0.1$			Length L(mm)	Maximum Acceptable Number Ignored
		$0.1 < W \leq 0.2$			$L \leq 11.0$	1
		$0.2 < W$			$11.0 < L$	None

### (3) Touch Panel Appearance

No.	ITEM	CRITERION		Zone	AQL
(1)	Foreign Material (Black or White Spots)	Average Diameter D(mm)	Criteria	A	2.5
		$D \leq 0.25$	Ignored		
		$0.25 < D \leq 0.35$	6		
		$0.35 < D$	None		
(2)	Foreign Material(Line) Or Scratches	Width W(mm)	Criteria	A	2.5
		$W \leq 0.05$	Ignored		
		$0.05 < W \leq 0.1$	$10 \leq L$ : None $L < 10$ : 4		
		$0.1 < W$	Spots Spec		
(3)	Fisheyes on Film Surface	Average Diameter D(mm)	Criteria	A	2.5
		$D \leq 0.2$	Ignored		
		$0.2 < D \leq 0.35$	6		
		$0.35 < D \leq 0.6$	2		
		$0.6 < D$	None		
(4)	Uncleanliness	No Conspicuous Dirt		A	2.5
(5)	Crack in Glass Plate	No Crack are Allowed		A	2.5

### 10.4 RELIABILITY TESTS

This standard reliability test is done only for the first lot of MP products. Customer and supplier must hold a discussion if other reliability test is requested by customer.

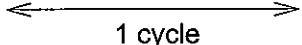
No.	TEST ITEM	TEST CONDITION
1	High Temperature and High Humidity Under Storage	40°C , 90%RH 120hrs
2	High Temperature and High Humidity Under Operation	40°C , 90%RH 72hrs
3	High Temperature Under Storage	70°C , 120hrs
4	Low Temperature Under Storage	-20°C , 120hrs
5	Thermal Shock (Under Storage)	$-20^{\circ}\text{C} \rightleftharpoons 25^{\circ}\text{C} \rightleftharpoons 60^{\circ}\text{C}$ 30min.      5min.      30min.  1 cycle total 5 cycles
6	Drop Test (Packing Box With Full Samples Inside)	(X,Y,Z) x2 total 6 directions drop from 1 meter to ground
7	ESD Test (Electro Staic Discharge Test)	$\pm 2.0 \text{ kV}$ 1 time for each terminal

• Operation : Supply 3.3V for logic system and  $V_{\text{LCD}}$  voltage for LCD module.

# 11. PRECAUTIONS FOR USE

## 11.1 MOUNTING PRECAUTION

Please mount the LCD module using mounting holes arranged in 4 corners, and please pay attention to the following.

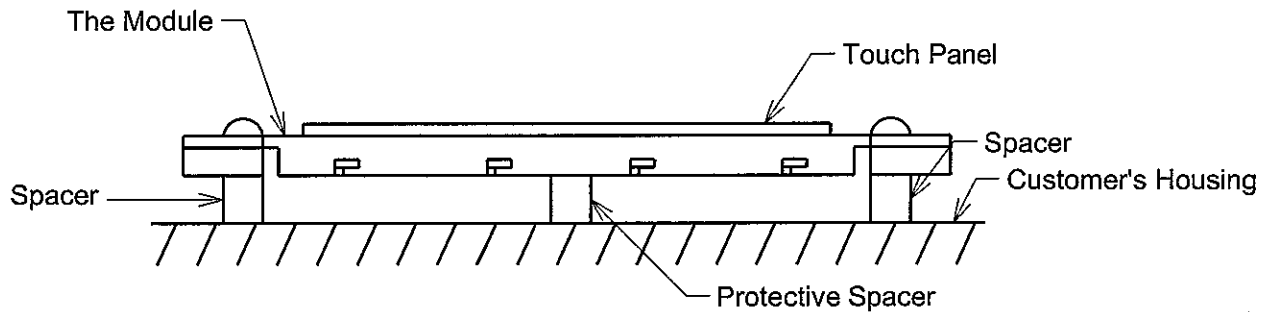

Example of Mounting

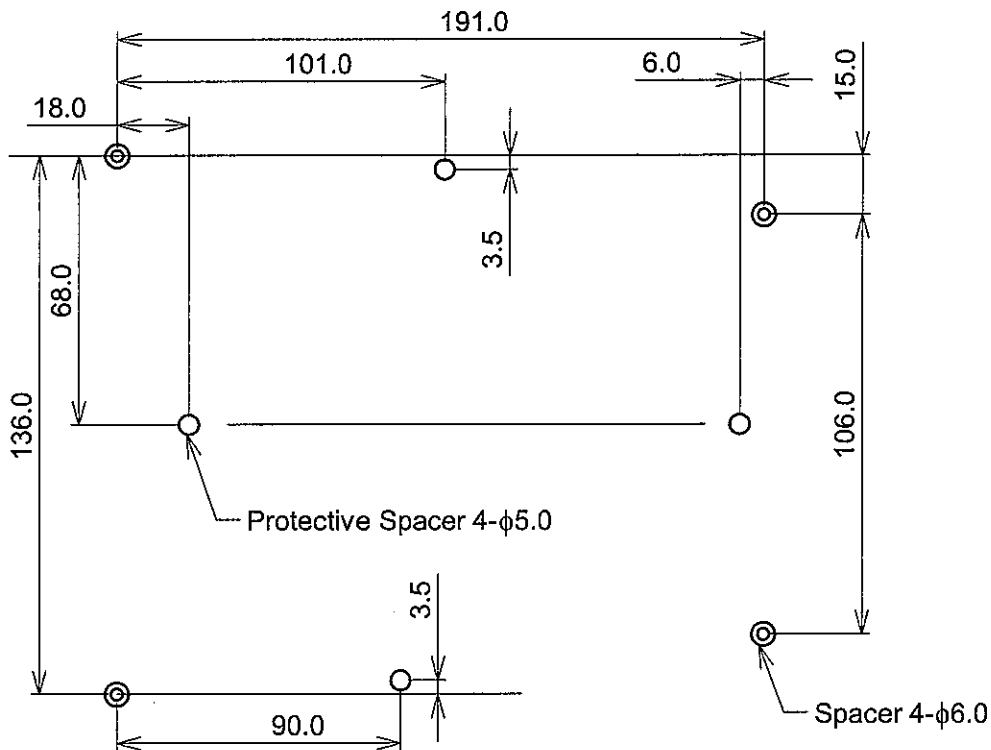

Location of Spacers

Unit : mm  
Scale : NTS

- (1) In order to protect the module from any kinds of shocks to your set, that to use projective spacers is recommended.
- (2) To prevent any pressure on the screen when the case or the screen is deformed by heat or other case, the clearance between the case and the Touch Panel is recommend to be designed.

- (3) For the module to be used at upright position, the case should have a structure to prevent the Touch Panel screen shift because of its own weight.
- (4) The case should be designed not to touch the tail (FPC) of Touch Panel.
- (5) The area between viewing area and insulated area is not stable. To prevent a potential pressure on this area, that the case opening is close to the viewing area is recommended.
- (6) When assembling the Touch Panel on your caes, please refer to the below figure.

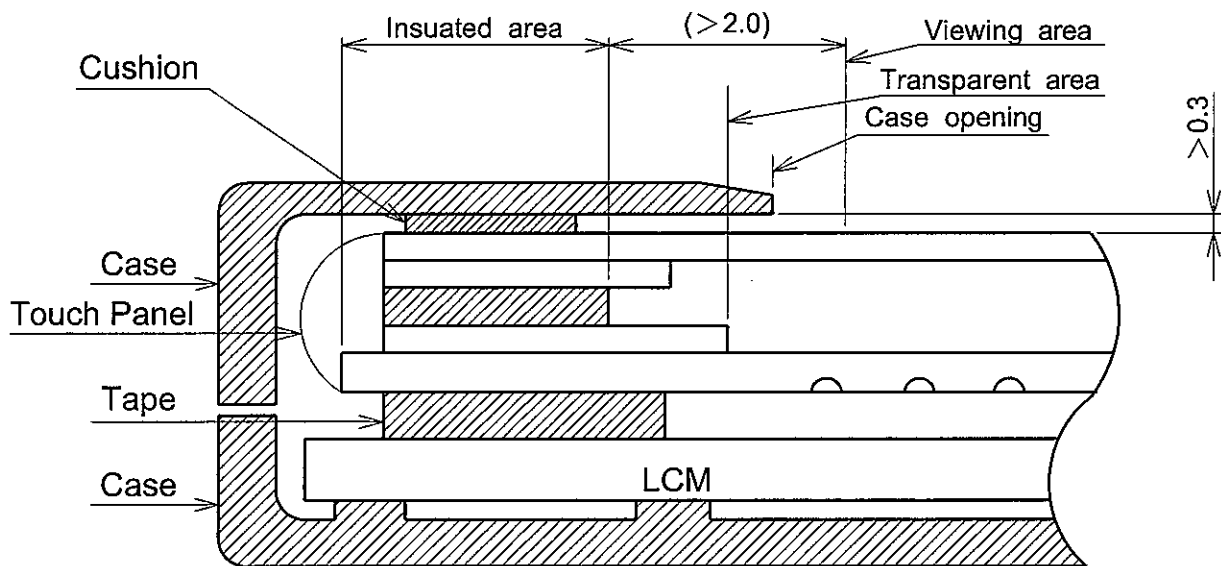

## 11.2 PRECAUTIONS FOR OPERATION

- (1) Since LCD panel is made of glass , in order to prevnt from glass broken or color tone change , please do not apply any mechanical shock or impact or excessive force to it when installing the LCD module.
- (2) If LCD panel is broken and liquid crystal substance leaks out and contact your skin or clothes , please immediately wash it off by using soap and water.
- (3) The polarizer on the LCD surface is soft and easily scratched. Please be careful when handling.
- (4) If LCD surface becomes contaminated , please wipe it off gently by using moisten soft cloth with normal hexane , do not use acetone , ketone , ethanol , isopropyl alcohol or water. If there is saliva or water on the LCD surface. Please wipe it off immediately.
- (5) When handling LCD module , please be sure that the body and the tools are properly grounded. And do not touch I/F pins with bare hands or contaminate I/F pins.
- (6) Do not attempt to disassemble or process the LCD module.
- (7) LCD module should be used under recommended operating conditions shown in chapter 5 and 6.
- (8) Response time will be extremely slower at lower temperature than at specified temperature and LCD will show different color when at higher temperature. The phenomenon will disappear when returning to specified condition.
- (9) Foggy dew , moisture condensation or water droplets deposited on surface and contact terminals will cause polarizer stain or damage , the deteriorated display quality and electrochemical reaction then leads to the shorter life time and permanent damage to the module probaly. Please pay attention to the environmental temperature and humidity.

## 11.3 PRECAUTIONS FOR STORAGE

- (1) Please store LCD module in a dark place , avoid exposure to sunlight , the light of fluorescent lamp or any ultraviolet ray.
- (2) Keep the environment temperature at between 10°C and 35°C and at normal humidity. Avoid high temperature , high humidity or temperature below 0°C.
- (3) That keeps the LCD modules stored in the container shipped from supplier before using them is recommended.
- (4) Do not leave any article on the LCD module surface for an extended period of time.

## 11.4 WARRANTY PERIOD

HITACHI warrants for a period of 12 months from the shipping date when stored or used under normal condition.

## 12. DESIGNATION OF LOT MARK

### 12.1 LOT MARK

Lot mark is consisted of 4 digits for production lot  
6 digits for production control.

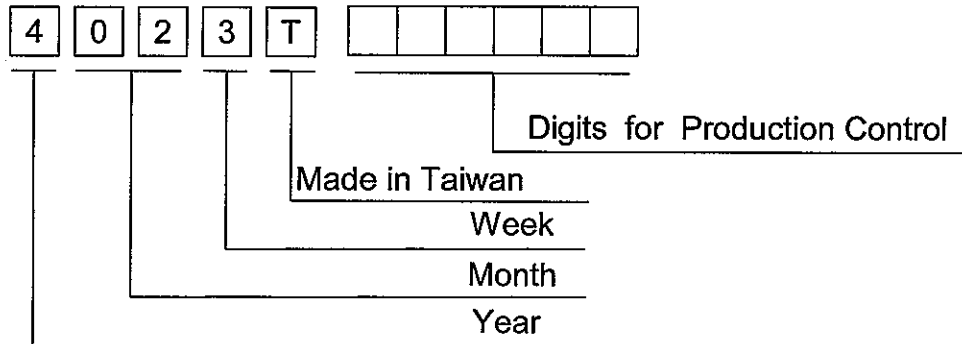

YEAR	FIGURE IN LOT MARK
2003	3
2004	4
2005	5
2006	6

MONTH	FIGURE IN LOT MARK	MONTH	FIGURE IN LOT MARK
Jan.	01	Jul.	07
Feb.	02	Aug.	08
Mar.	03	Sep.	09
Apr.	04	Oct.	10
May	05	Nov.	11
Jun.	06	Dec.	12

WEEK (DAY IN CALENDAR)	FIGURE IN LOT MARK
01~07	1
08~14	2
15~21	3
22~28	4
29~31	5

### 12.2 REVISION

REV. No.	ITEM	LOT No.
A		000001~

### 12.3 LOCATION OF LOT MARK : On the back side of LCM

Example:

HITACHI SX19V010-ZZA 4023T  
MADE IN TAIWAN REV. A 000001