

# **LQ043T3DX02**

## **TFT-LCD Module**

Spec. Issue Date: Feb. 8, 2005

No: LCP-05005

**SHARP**

No.	LCM-05005
DATE	8.Feb.2005

**TECHNICAL DOCUMENT**  
**FOR**  
**TFT-LCD module**

MODEL No.           LQ043T3DX02          

This technical document is subject to change without notice.  
 Therefore, it is recommended to contact Sharp Corporation or  
 its representative before designing your product based on this document.

CONFIDENTIAL

SHARP CORPORATION  
 MOBILE LIQUID CRYSTAL DISPLAY GROUP  
 MOBILE LCD DESIGN CENTER II  
 ENGINEERING DEPARTMENT II



- This technical document includes information and/or data that are subjected to Sharp's copyrights. Please see to it that this technical document be handled with utmost care. No part may be copied without our permission.
  
- The examples of applications given herein are only intended for explaining typical applications of our product. Moreover, presenting this technical document does not mean giving our warranty or licensing any industrial property rights or other rights. Besides, Sharp will not hold itself responsible for any issue that may arise with a third party on industrial property rights from or with regard to use of the product.
  
- This product has been developed and manufactured for applications to mobile instrument products.
  
- If this product is to be used for any other systems that require high reliability and safety in performance, accuracy, etc, such as transportation systems (aircrafts, trains, mobiles), security or fire-prevention systems, any other safety devices, etc, you are requested to allow for safety design of the entire system or device, such as fail-safe and redundancy design so as to maintain and assure its reliability and safety.
  
- Do not apply this product for aerospace systems, mainline communication systems, nuclear power control systems or medical equipment involved in life support that require high reliability and safety, as it is not intended for such use or application.
  
- Sharp shall not be liable for or indemnify any loss or damage that may arise from use or application of the product without observing our cautions, conditions, etc. as stated in this technical document.
  
- If there is anything unclear to you regarding the product, please contact our staff in charge of sales.

## Contents

1. Applicable Scope .....	5
2. General Description .....	5
3. Mechanical (Physical) Specifications .....	5
4. Input Terminal Names and Functions .....	6
5. Absolute Maximum Ratings .....	7
6. Electrical Characteristics .....	8
7. Timing Characteristics of Input Signal .....	11
8. Input Signal and Display Color .....	14
9. Optical Characteristics .....	15
10. Handling of Modules .....	17
11. Reliability Test Conditions .....	18
12. Display Grad .....	18
13. Lot Number Marking .....	19
14. Others .....	19
15. Outline dimension .....	20

**CONFIDENTIAL**

## 1. Applicable Scope

This technical document is applicable to TFT-LCD Module "LQ043T3DX02" only.

## 2. General Description

This module is a color active matrix LCD module incorporating amorphous silicon TFT(Thin Film Transistor). It is composed of a color TFT-LCD panel, driver ICs, Input FPC and a back light unit. Graphics and texts can be displayed on a 480×3×272 dots panel with about 16million colors by supplying 24bit data signals (8bit×RGB), Four timing signals, logic (typ. +2.5V), analog (typ. +5V) supply voltages for TFT-LCD panel driving and supply voltage for back light.

## 3. Mechanical (Physical) Specifications

Item	Specifications	Unit
Screen size	10.9 (4.3" type) diagonal	
Active area	95.04(H)×53.856(V)	mm
Pixel format	480×272	pixel
	1Pixel =R+G+B dots	
Pixel pitch	0.198(H)×0.198(V)	mm
Pixel configuration	R,G,B vertical stripes	
Display mode	Normally black	
Unit outline dimensions	105.4(W)×67.2(H)×3.95(D)	mm
Mass	50	g
Polarizer · Surface treatment	Clear hard coat	

※ The above-mentioned table indicates module sizes without some projections and FPC.

## 4. Input Terminal Names and Functions

### 4-1. TFT LCD Panel Driving (Reference Connector :

Hirose Electric CO., LTD. Product No.: FH12A-40S-0.5SH(55) Top contact type)

※ Bottom contact type connectors are also prepared. Ex: FH12-40S-0.5SH(55)

※ The FPCs of this LCD module are gold plated, so the connector contacts should be also gold plated.

Terminal No.	Terminal name	Function	Remarks
1	GND	GND(0V)	
2	GND	GND(0V)	
3	VCC	+2.5V power source	
4	VCC	+2.5V power source	
5	R0	RED Data Signal (LSB)	
6	R1	RED Data Signal	
7	R2	RED Data Signal	
8	R3	RED Data Signal	
9	R4	RED Data Signal	
10	R5	RED Data Signal	
11	R6	RED Data Signal	
12	R7	RED Data Signal (MSB)	
13	G0	GREEN Data Signal (LSB)	
14	G1	GREEN Data Signal	
15	G2	GREEN Data Signal	
16	G3	GREEN Data Signal	
17	G4	GREEN Data Signal	
18	G5	GREEN Data Signal	
19	G6	GREEN Data Signal	
20	G7	GREEN Data Signal (MSB)	
21	B0	BLUE Data Signal (LSB)	
22	B1	BLUE Data Signal	
23	B2	BLUE Data Signal	
24	B3	BLUE Data Signal	
25	B4	BLUE Data Signal	
26	B5	BLUE Data Signal	
27	B6	BLUE Data Signal	
28	B7	BLUE Data Signal (MSB)	
29	GND	GND(0V)	
30	CK	Clock signal to sample each date	
31	DISP	Display ON/OFF Signal	
32	Hsync	Horizontal synchronizing signal	
33	Vsync	Vertical synchronizing signal	
34	NC	NC	Note 1
35	AVDD	+5V Analog power source	
36	AVDD	+5V Analog power source	
37	NC	NC	Note 1
38	TEST1	TEST1	Note 2
39	TEST2	TEST2	Note 3
40	TEST3	TEST3	Note 3

Note 1) They have been open within FPC.

Note 2) Please be sure to set 38 pins (TEST1) to open.

Note 3) Please be sure to connect 39 pin (TEST2) ,40 pin (TEST3) with GND.

## 4-2. Backlight

0.5mmP 4Pin FPC (Reference Connector :

Kyocera Elco Corporation Product No. : 6298 Bottom contact type)

※ Top contact type connectors are also prepared.

※ The FPCs of this LCD module are gold plated, so the connector contacts should be also gold plated.

Terminal No.	Signal	Function
1	V <sub>LED-</sub>	LED Power Source Input terminal (Cathode side)
2	NC	No Connection
3	NC	No Connection
4	V <sub>LED+</sub>	LED Power Source Input terminal (Anode side)

## 5. Absolute Maximum Ratings

Item	Symbol	Conditions	Rated value	Unit	Remarks
Input voltage	V <sub>I</sub>	Ta=25°C	-0.3 ~ V <sub>CC</sub> +0.3	V	【Note 1】
2.5 V Power supply voltage	V <sub>CC</sub>	Ta=25°C	0 ~ +4.5	V	
5 V Power supply voltage	AV <sub>DD</sub>	Ta=25°C	0 ~ +5.0	V	
Temperature for storage	T <sub>stg</sub>	—	-25 ~ +60	°C	【Note 2】
Temperature for operation	T <sub>opa</sub>	—	-10 ~ +50	°C	【Note 3】
LED Input electric current	I <sub>LED</sub>	Ta=25°C	25	mA	【Note 4】
LED electricity consumption	P <sub>LED</sub>	Ta=25°C	100	mW	【Note 4】

【Note 1】 CK,R0~R7,G0~G7,B0~B7, Hsync, Vsync, DISP

【Note 2】 Humidity : 80%RHMax. (Ta≤40°C)

Maximum bulb temperature under 39°C (Ta>40°C) See to it that no dew will be condensed.

【Note 3】 Panel surface temperature prescribes.

(Reliability is examined at ambient temperature of 50°C.)

【Note 4】 Power consumption of one LED (Ta=25°C) (use LED NESW008B 7pieces)

Ambient temperature and the maximum input are fulfilling the following operating conditions.

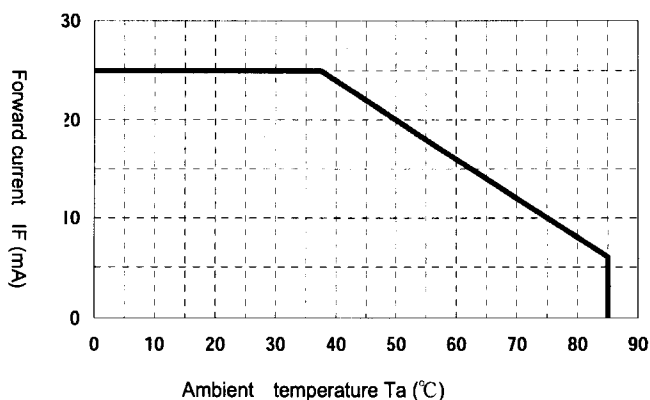

Ambient temperature and the maximum input



## 6. Electrical Characteristics

### 6-1. TFT LCD Panel Driving

Ta = 25°C

Item		Symbol	Min.	Typ.	Max.	Unit	Remarks
+2.5V power supply	DC voltage	VCC	+2.3	+2.5	+3.3	V	[Note 1]
	DC Current	ICC		1.2	3	mA	[Note 2]
+5V power supply	DC voltage	AVDD	+4.8	+5.0	+5.2	V	[Note 1]
	DC Current	I <sub>AVDD</sub>		10	18	mA	[Note 2]
Permissible Input ripple voltage		V <sub>RFVCC</sub>			100	mVp-p	V <sub>CC</sub> =+2.5V
		V <sub>RFAVDD</sub>			100	mVp-p	V <sub>CC</sub> =+5.0V
Input voltage (Low)		V <sub>IL</sub>			0.2 V <sub>CC</sub>	V	[Note 3]
Input voltage (High)		V <sub>IH</sub>	0.8 V <sub>CC</sub>			V	
Input current (Low)		I <sub>OL</sub>			4.0	μA	V <sub>I</sub> =0V [Note 3]
Input current (High)		I <sub>OH</sub>			4.0	μA	V <sub>I</sub> =2.5V [Note 3]

※ The rush current will flows when power supply is turned on, so please design the power supply circuit referring to [Note 4]  
(The rush current changes according to the condition of the supply voltage value, rising time and so on.)

[Note 1]

Sequences of supply voltage and signals

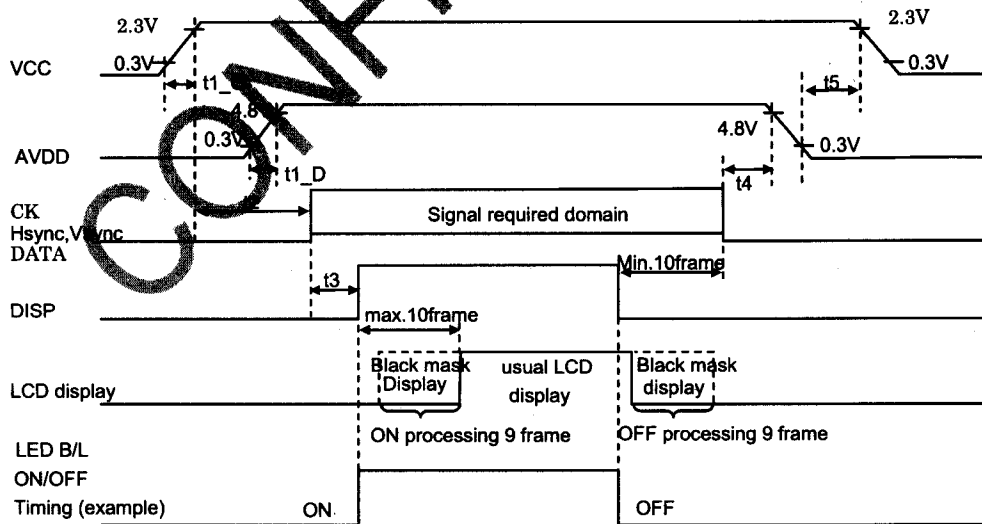

- ◎ Please do not supply AVDD before VCC.
- ◎ It discharges and boost up voltage for TFT module on the basis of a DISP-signal  
It drives Max-10 frames (about 0.2seconds) from change of DISP-signals by reasons that  
It takes time for 9 frames while each processing operation.  
Therefore, the display start is delayed for 10 frames and Ten or more frames needs to be  
voltage maintained at the time of a display end.
- ◎ It is not problem to set up DISP=L , ANDD=GND when VCC voltage is supplied
- ◎ Please don't set various signals to Hi-Z when VCC-voltage is supplied  
in reason that those signals are CMOS input.
- ◎ Don't change DISP signal into the state of H level When AVDD voltage is in the state of GND.
- ◎ The ON/OFF timing of LED Back Light is an example.

	MIN	TYP	MAX	unit
t1_C	0	—	10	ms
t1_D	0.5	—	10	ms
t2	50	—	—	ms
t3	0	—	—	ms
t4	0	—	—	ms
t5	0	—	—	ms

Dip Conditions for supply voltage

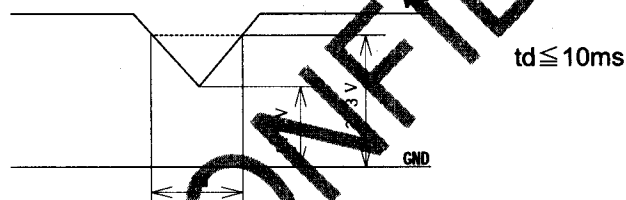

【Note 2】

Typical current situation: 256-gray-bar pattern VCC=2.5V AVDD=5.0V

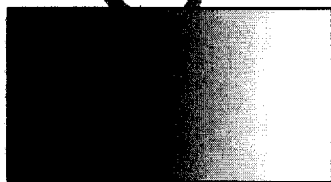

【Note 3】 CK, R0~R7, G0~G7, B0~B7, Hsync, Vsync, DISP

[ Note 4 ]

An example of rush current measurement

◎ Measurement conditions

- Power supply voltage VCC : 2.5V AVDD : 5.0V
- Disp signal : OFF ⇒ ON
- Other input signals : GND
- Measurement system : refer to right Fig.
- rush current measurement timing : refer to following Fig.

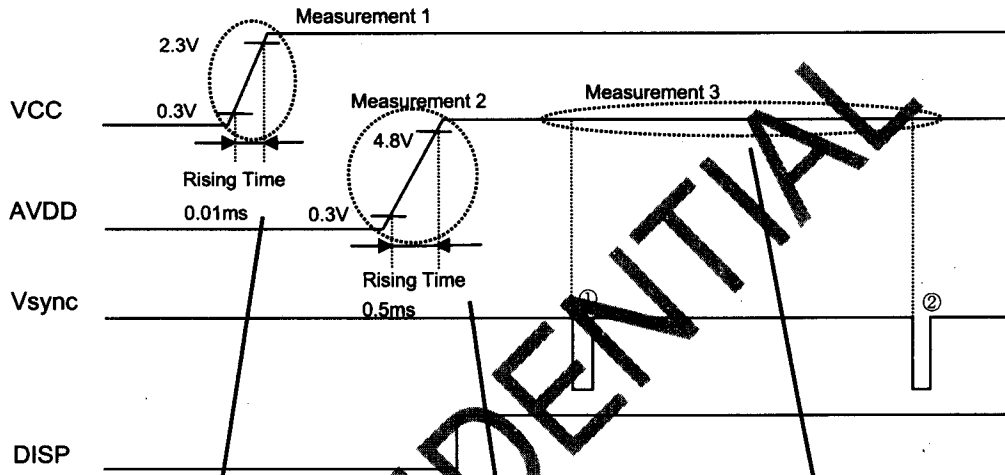
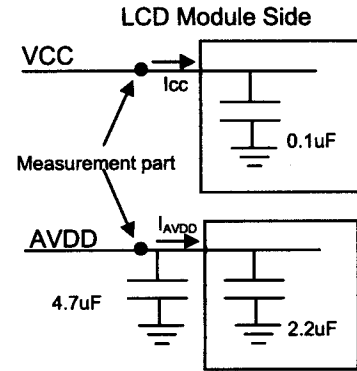

◎ Measurement Example

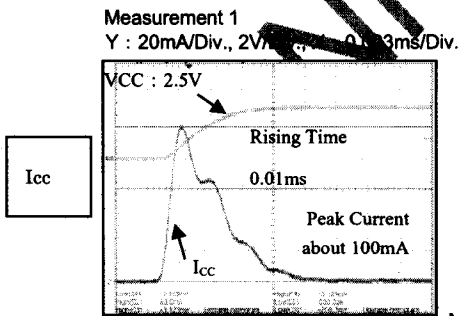

I<sub>AVDD</sub>

Measurement 2  
Y : 20mA/Div., 2V/Div., X : 0.08ms/Div.  
Measurement 3  
Y : 50mA/Div., 5V/Div., X : 4ms/Div.

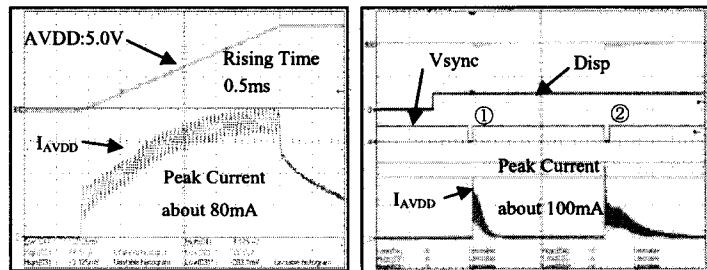

These rush current won't flow stationary,

these will flow at the timing shown in Measurement 3.

## 6-2. Back light driving

The back light system has seven LEDs

[NESW008B]

Parameter	Symbol	Min.	Typ.	Max.	Unit	Remark
Rated Voltage	V <sub>BL</sub>	—	—	29.4	V	
Rated Current	I <sub>L</sub>	—	18	20	mA	Ta=25°C

## 7. Timing characteristics of input signals

An input signal timing waveform is shown in Fig. 2.

### 7-1 Timing characteristics

Parameter		Symbol	Min.	Typ.	Max.	Unit	Remark
Clock	Frequency	1/Tc	7.83	9.00	9.26	MHz	
	Duty ratio	Th/T	40	50	60	%	
Data	Set up time	Tds	25	—	—	ns	
	Hold time	Tdh	25	—	—	ns	
Horizontal synchronizing	Period	TH	—	525	—	Clock	
	Pulse width	THp	—	41	—	Clock	
	Horizontal period	THd	—	480	—	Clock	
	Back porch	THb	—	2	—	Clock	
	Front porch	THf	—	2	—	Clock	
Vertical synchronizing	Period	TV	—	286	—	Line	
	Pulse width	TVp	—	9	—	Line	
	Vertical period	TVd	—	272	—	Clock	
	Back porch	TVb	—	2	—	Line	
	Front porch	TVf	—	2	—	Line	

- [Note]
- In case of using the slow frequency, the deterioration of display, flicker etc may occur.
  - The timing characteristics are basically fixed as above.

7-2 Timing details

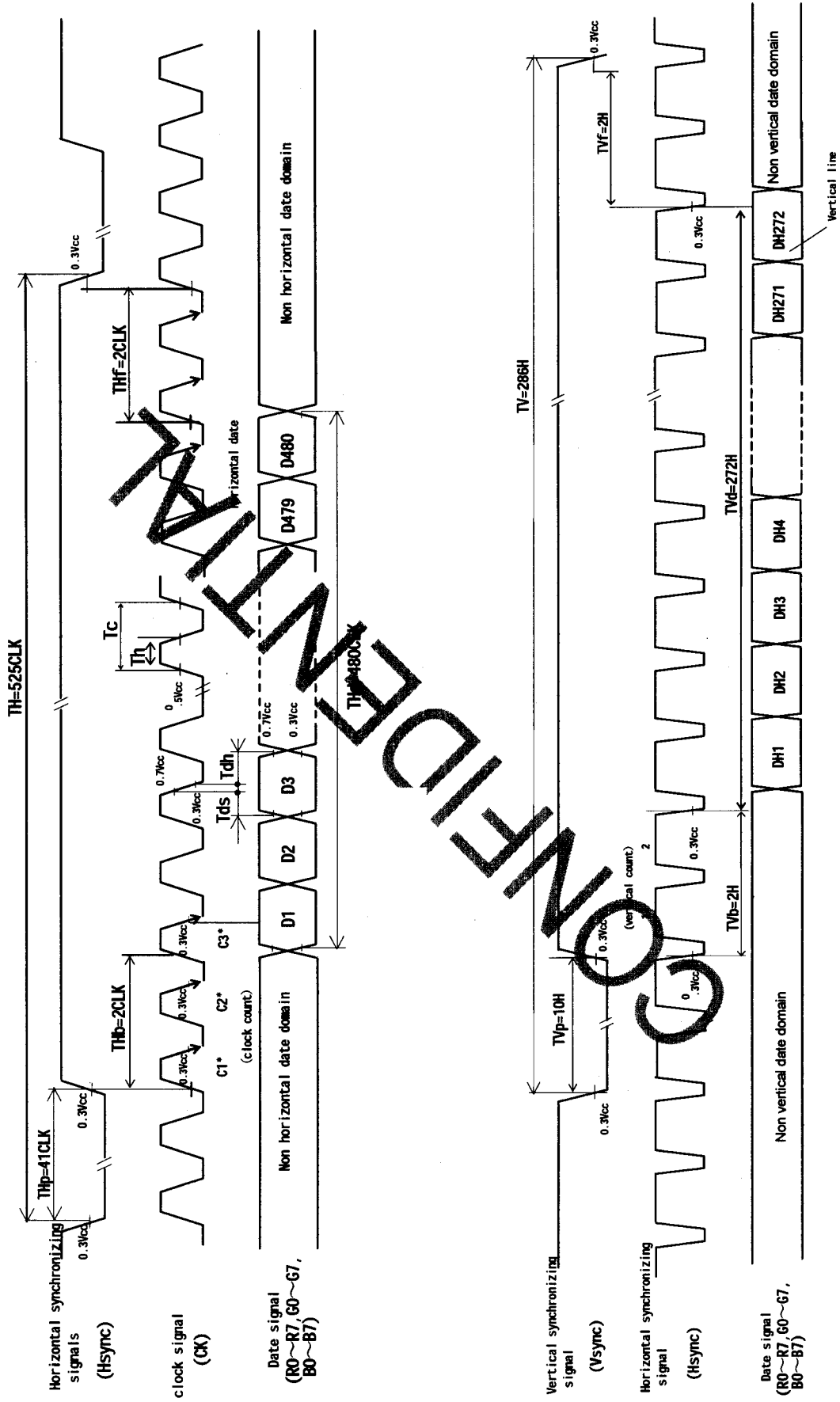
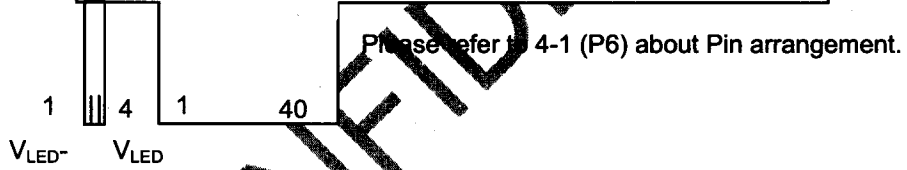
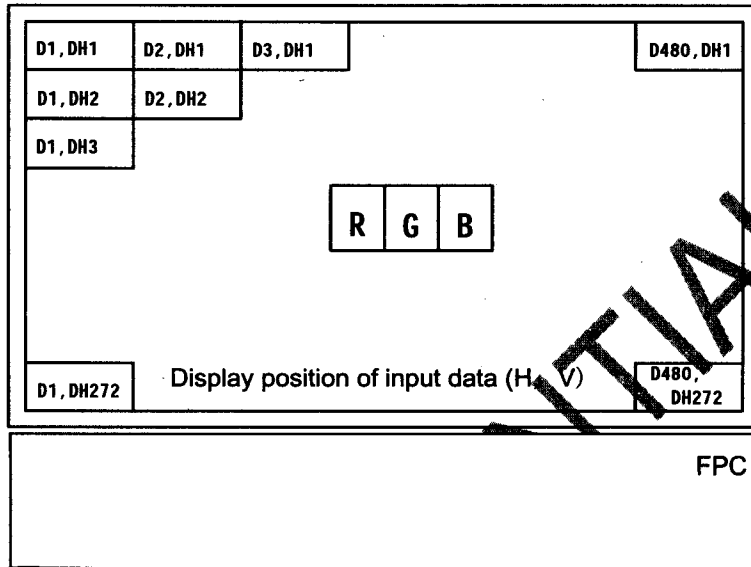

Fig 2 Input signal timing

## 7-3 Input Data Signals and Display Position on the screen



Please refer to 4-2 (P7) about LED side Pin arrangement.

CONFIDENTIAL

## 8. Input Signals, Basic Display Colors and Gray Scale of Each Color

Colors & Gray Scale	Data signal																											
	Gray	R0	R1	R2	R3	R4	R5	R6	R7	G0	G1	G2	G3	G4	G5	G6	G7	B0	B1	B2	B3	B4	B5	B6	B7			
	Scale	LSB							MSB							LSB							MSB					
Basic Color	Black	—	0	0	0	0	0	0	0	0	0	0	0	0	0	0	0	0	0	0	0	0	0	0	0			
	Blue	—	0	0	0	0	0	0	0	0	0	0	0	0	0	0	0	0	1	1	1	1	1	1	1	1		
	Green	—	0	0	0	0	0	0	0	0	1	1	1	1	1	1	1	1	0	0	0	0	0	0	0	0		
	Cyan	—	0	0	0	0	0	0	0	0	1	1	1	1	1	1	1	1	1	1	1	1	1	1	1	1		
	Red	—	1	1	1	1	1	1	1	1	0	0	0	0	0	0	0	0	0	0	0	0	0	0	0	0		
	Magenta	—	1	1	1	1	1	1	1	1	0	0	0	0	0	0	0	0	1	1	1	1	1	1	1	1		
	Yellow	—	1	1	1	1	1	1	1	1	1	1	1	1	1	1	1	1	0	0	0	0	0	0	0	0		
	White	—	1	1	1	1	1	1	1	1	1	1	1	1	1	1	1	1	1	1	1	1	1	1	1	1		
Gray Scale of Red	Black	GS0	0	0	0	0	0	0	0	0	0	0	0	0	0	0	0	0	0	0	0	0	0	0	0			
	↑	GS1	1	0	0	0	0	0	0	0	0	0	0	0	0	0	0	0	0	0	0	0	0	0	0			
	Darker	GS2	0	1	0	0	0	0	0	0	0	0	0	0	0	0	0	0	0	0	0	0	0	0	0			
	↑	↓																										
	↓	↓																										
	Brighter	GS253	1	0	1	1	1	1	1	1	0	0	0	0	0	0	0	0	0	0	0	0	0	0	0			
	↓	GS254	0	1	1	1	1	1	1	1	0	0	0	0	0	0	0	0	0	0	0	0	0	0	0			
	Red	GS255	1	1	1	1	1	1	1	1	0	0	0	0	0	0	0	0	0	0	0	0	0	0	0	0		
Gray Scale of Green	Black	GS0	0	0	0	0	0	0	0	0	0	0	0	0	0	0	0	0	0	0	0	0	0	0	0			
	↑	GS1	0	0	0	0	0	0	0	0	1	0	0	0	0	0	0	0	0	0	0	0	0	0	0			
	Darker	GS2	0	0	0	0	0	0	0	0	0	1	0	0	0	0	0	0	0	0	0	0	0	0	0			
	↑	↓																										
	↓	↓																										
	Brighter	GS253	0	0	0	0	0	0	0	0	1	0	1	1	1	1	1	1	0	0	0	0	0	0	0			
	↓	GS254	0	0	0	0	0	0	0	0	0	1	1	1	1	1	1	1	0	0	0	0	0	0	0			
	Green	GS255	0	0	0	0	0	0	0	0	1	1	1	1	1	1	1	1	0	0	0	0	0	0	0	0		
Gray Scale Blue	Black	GS0	0	0	0	0	0	0	0	0	0	0	0	0	0	0	0	0	0	0	0	0	0	0	0			
	↑	GS1	0	0	0	0	0	0	0	0	0	0	0	0	0	0	0	0	1	0	0	0	0	0	0			
	Darker	GS2	0	0	0	0	0	0	0	0	0	0	0	0	0	0	0	0	0	1	0	0	0	0	0			
	↑	↓																										
	↓	↓																										
	Brighter	GS253	0	0	0	0	0	0	0	0	0	0	0	0	0	0	0	0	1	0	1	1	1	1	1			
	↓	GS254	0	0	0	0	0	0	0	0	0	0	0	0	0	0	0	0	0	1	1	1	1	1	1			
	Blue	GS255	0	0	0	0	0	0	0	0	0	0	0	0	0	0	0	0	1	1	1	1	1	1	1	1		

0 : Low level voltage    1 : High level voltage

Each basic color can be displayed in 256 gray scales from 8 bit data signals. According to the combination of 24 bit data signals, the 16-million-color display can be achieved on the screen.

## 9. Optical Characteristics

### Module characteristics

Ta = 25°C, VCC = +2.5V, AVDD = 5.0V

Parameter		Symbol	Condition	Min.	Typ.	Max.	Unit	Remark
Viewing angle range	Horizontal	$\theta_{21, \theta_{22}}$	CR > 10	—	80	—	Deg.	【Note1,4】
	Vertical	$\theta_{11}$		—	80	—	Deg.	
		$\theta_{12}$		—	80	—	Deg.	
Contrast ratio		CR	$\theta = 0^\circ$	100	400	—		【Note2,4】
Response Time	Rise	$\tau_r$	$\theta = 0^\circ$	—	30	45	ms	【Note3,4】
	Decay	$\tau_d$		—	30	45	ms	
Chromaticity of White		x		0.246	0.296	0.346		【Note4】
		y		0.293	0.343	0.393		
Luminance of white		XL1		—	165	—	cd/m <sup>2</sup>	ILED=18mA 【Note4】

※ The optical characteristics measurements are operated under a stable luminescence (I<sub>LED</sub> = 18mA) and a dark condition. (refer to Fig.3)

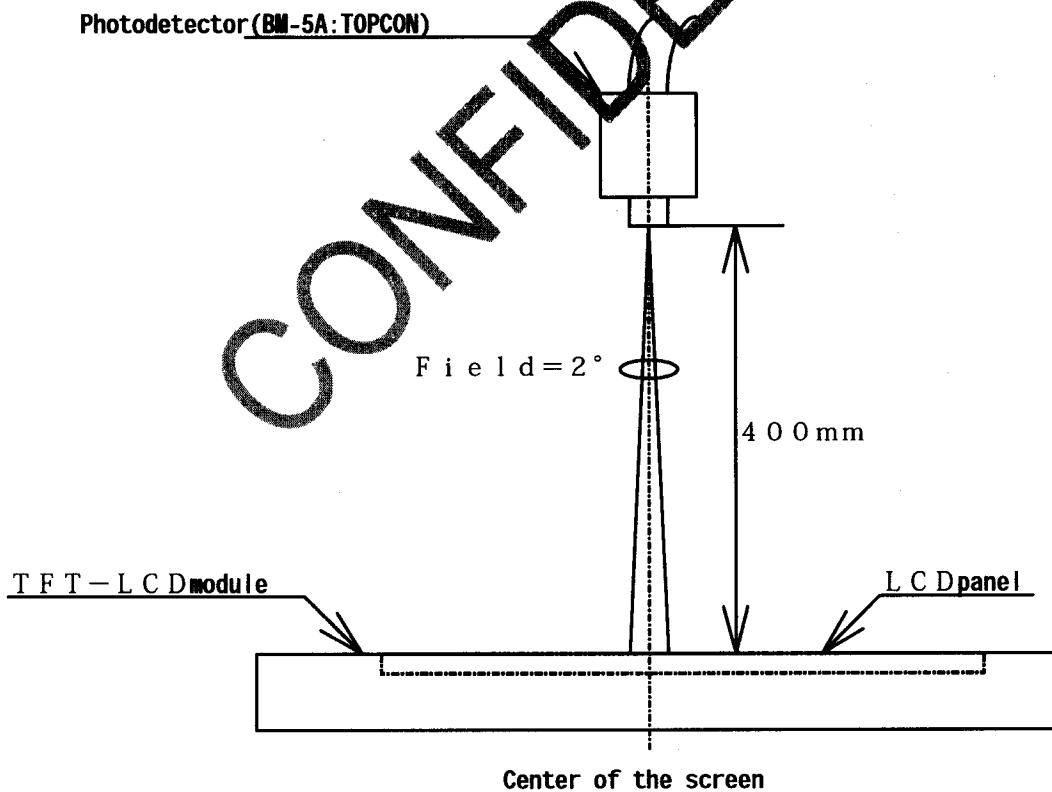
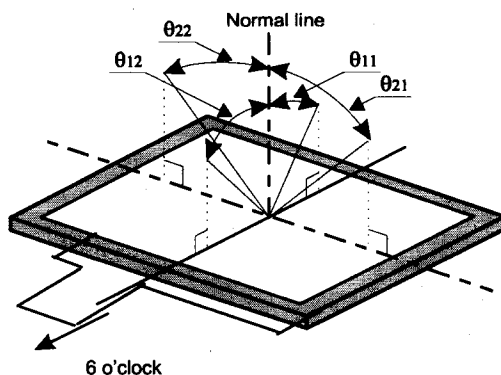

Fig.3 Optical characteristics measurement method



【 Note 1 】 Definitions of viewing angle range



【 Note 2 】 Definition of contrast ratio

The contrast ratio is defined as the following

$$\text{Contrast ratio(CR)} = \frac{\text{Luminance (brightness) with all pixels white}}{\text{Luminance (brightness) with all pixels black}}$$

【 Note 3 】 Definition of response time

The response time is defined as the following figure and shall be measured by switching the input signal for "black" and "white"

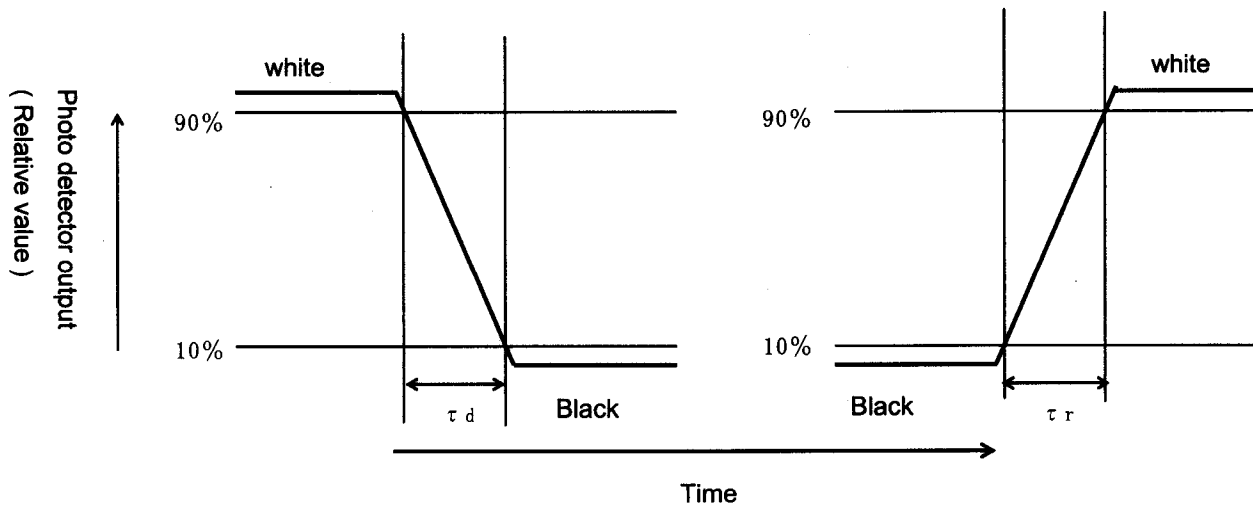

【 Note 4 】 This shall be measured at center of the screen.

## 10. Handling of modules

### 10-1 Inserting the FPC into its connector and pulling it out.

- ① Be sure to turn off the power supply and the signals when inserting or disconnecting the cable.
- ② Please insert for too much stress not to join FPC in the case of insertion of FPC.

### 10-2 About handling of FPC

- ① The bending radius of the FPC should be more than 1.4mm, and it should be bent evenly.
- ② Do not dangle the LCD module by holding the FPC, or do not give any stress to it.

### 10-3 Mounting of the module

- ① The module should be held on to the plain surface. Do not give any warping or twisting stress to the module.
- ② Please consider that GND can ground a modular metal portion etc. so that static electricity is not charged to a module.

### 10-4 Cautions in assembly / Handling pre cautions.

As the polarizer can be easily scratched, be most careful in handling it.

- ① Work environments in assembly.

Working under the following environments is desirable:

- a) Implement more than  $1M\Omega$  conductive treatment (by placing a conductive mat or applying Conductive paint) on the floor or tiles.
  - b) No dusts come in to the working room. Place an adhesive, anti-dust mat at the entrance of the room.
  - c) Humidity of 50~70% and temperature of 15~27°C are desirable.
  - d) All workers wear conductive shoes, conductive clothes, conductive fingerstalls and grounding belts without fail.
  - e) Use a blower for electrostatic removal. Set it in a direction slightly tilt downward so that each Module can be well subjected to its wind. Set the blower at an optimum distance between the blower and the module.
- ② How the remove dust on the polarizer
    - a) Blow out dust by the use of an N2 blower with antistatic measures taken. Use of an ionized air Gun is recommendable.
    - b) When the panel surface is soiled, wipe it with soft cloth.
  - ③ In the case of the module's metal part (shield case) is stained, wipe it with a piece of dry, soft cloth. If rather difficult, give a breath on the metal part to clean better.
  - ④ If a water dropped, etc. remains stuck on the polarizer for a long time, it is apt to get discolored or cause stains. Wipe it immediately.
  - ⑤ As a glass substrate is used for the TFT-LCD panel, if it is dropped on the floor or hit by something hard, it may be broken or chipped off.
  - ⑥ Since CMOS LSI is used in this module, take care of static electricity and take the human earth into consideration when handling.

## 10-5 Others

- ① Regarding storage of LCD modules, avoid storing them at direct sunlight-situation.

You are requested to store under the following conditions:

(Environmental conditions of temperature/humidity for storage)

- (1) Temperature: 0~40°C
- (2) Relative humidity : 95% or less
  - As average values of environments (temperature and humidity) for storing, use the following control guidelines:
    - Summer season: 20~35°C, 85% or less Winter season: 5~15°C, 85% or less
  - If stored under the conditions of 40°C and 95% RH, cumulative time of storage must be less than 240 hours.
- ② If stored at temperatures below the rated values, the inner liquid crystal may freeze, causing cell destruction. At temperatures exceeding the rated values for storage, the liquid crystal may become isotropic liquid, making it no longer possible to come back to its original state in some cases.
- ③ If the LCD is broken, do not drink liquid crystal in the mouth. If the liquid crystal adheres to a hand or foot or to clothes, immediately cleanse it with soap.
- ④ If a water drop or dust adheres to the polarizer, it is apt to cause deterioration. Wipe it immediately.
- ⑤ Be sure to observe other caution items for ordinary electronic parts and components.

## 11. Reliability test items

No.	Test item	Conditions
1	High temperature storage test	Ta = 60°C 240h
2	Low temperature storage test	Ta = -25°C 240h
3	High temperature & high humidity operation test	Ta = 40°C ; 95%RH 240h (No condensation)
4	High temperature operation test	Ta = 50°C 240h (The panel temp. must be less than 50°C)
5	Low temperature operation test	Ta = -10°C 240h
6	Vibration test (non- operation)	Frequency : 10~55Hz/Vibration width (one side) : 1.5mm Sweep time : 1minutes Test period : (2 hours for each direction of X,Y,Z)
7	Shock test	Direction : ±X, ±Y, ±Z, Time : Third for each direction. Impact value : 100G Action time 6ms
8	Thermal shock test	Ta=-25°C~60°C /10 cycles (30 min) (30min)

### 【Result Evaluation Criteria】

Under the display quality test conditions with normal operation state, these shall be no change which may affect practical display function.

## 12. Display Grade

The standard regarding the grade of color LCD displaying modules should be based on the delivery inspection standard.

### 13. Lot No. marking

The lot No. will be indicated on individual labels. The location is as shown

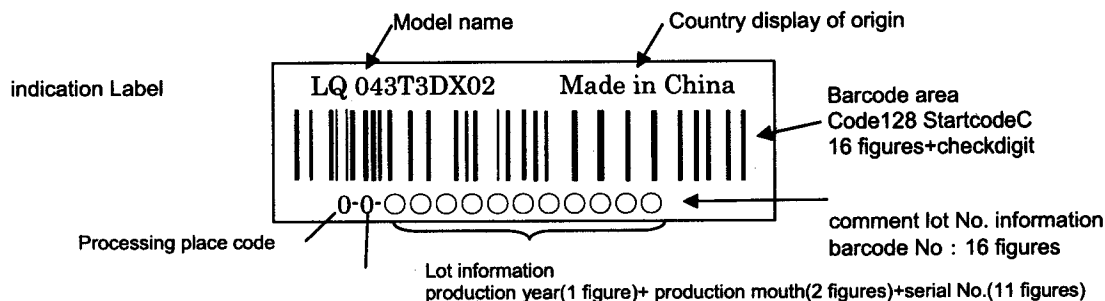

outward form : width  $29.0 \pm 0.5\text{mm}$  length  $11.5 \pm 0.5\text{mm}$

comment column :

- 1 figure Processing place code 「0」 WSEC Wuxi Factory  
「1」 WSEC Lianyungang Factory
- 2 figures Change history administration No. 「0」
- 3 figures Production year
- 4, 5 figures Production month
- 6 -16 figures Serial No.

### 14. Others

- 1 Disassembling the module can cause permanent damage and you should be strictly avoided.
- 2 Please be careful that you don't keep the screen displayed fixed pattern image for a long time, since retention may occur.
- 3 If you pressed down a liquid crystal display screen with your finger and so on, the alignment disorder of liquid crystal will occur. And then It will become display fault.  
Therefore, Be careful not to touch the screen directly, and to consider not stressing to it.
- 4 In the circuit parts on FPC, We don't change LCD module parts without announcements.

CONFIDENTIAL



## **SPECIFICATIONS ARE SUBJECT TO CHANGE WITHOUT NOTICE.**

Suggested applications (if any) are for standard use; See Important Restrictions for limitations on special applications. See Limited Warranty for SHARP's product warranty. The Limited Warranty is in lieu, and exclusive of, all other warranties, express or implied. ALL EXPRESS AND IMPLIED WARRANTIES, INCLUDING THE WARRANTIES OF MERCHANTABILITY, FITNESS FOR USE AND FITNESS FOR A PARTICULAR PURPOSE, ARE SPECIFICALLY EXCLUDED. In no event will SHARP be liable, or in any way responsible, for any incidental or consequential economic or property damage.

---

# **SHARP**<sup>®</sup>

### **NORTH AMERICA**

---

SHARP Microelectronics of the Americas  
5700 NW Pacific Rim Blvd.  
Camas, WA 98607, U.S.A.  
Phone: (1) 360-834-2500  
Fax: (1) 360-834-8903  
Fast Info: (1) 800-833-9437  
www.sharpsma.com

### **EUROPE**

---

SHARP Microelectronics Europe  
Division of Sharp Electronics (Europe) GmbH  
Sonninstrasse 3  
20097 Hamburg, Germany  
Phone: (49) 40-2376-2286  
Fax: (49) 40-2376-2232  
www.sharpsme.com

### **JAPAN**

---

SHARP Corporation  
Electronic Components & Devices  
22-22 Nagaike-cho, Abeno-Ku  
Osaka 545-8522, Japan  
Phone: (81) 6-6621-1221  
Fax: (81) 6117-725300/6117-725301  
www.sharp-world.com

### **TAIWAN**

---

SHARP Electronic Components  
(Taiwan) Corporation  
8F-A, No. 16, Sec. 4, Nanking E. Rd.  
Taipei, Taiwan, Republic of China  
Phone: (886) 2-2577-7341  
Fax: (886) 2-2577-7326/2-2577-7328

### **SINGAPORE**

---

SHARP Electronics (Singapore) PTE., Ltd.  
438A, Alexandra Road, #05-01/02  
Alexandra Technopark,  
Singapore 119967  
Phone: (65) 271-3566  
Fax: (65) 271-3855

### **KOREA**

---

SHARP Electronic Components  
(Korea) Corporation  
RM 501 Geosung B/D, 541  
Dohwa-dong, Mapo-ku  
Seoul 121-701, Korea  
Phone: (82) 2-711-5813 ~ 8  
Fax: (82) 2-711-5819

### **CHINA**

---

SHARP Microelectronics of China  
(Shanghai) Co., Ltd.  
28 Xin Jin Qiao Road King Tower 16F  
Pudong Shanghai, 201206 P.R. China  
Phone: (86) 21-5854-7710/21-5834-6056  
Fax: (86) 21-5854-4340/21-5834-6057

#### **Head Office:**

No. 360, Bashen Road,  
Xin Development Bldg. 22  
Waigaoqiao Free Trade Zone Shanghai  
200131 P.R. China  
Email: smc@china.global.sharp.co.jp

### **HONG KONG**

---

SHARP-ROXY (Hong Kong) Ltd.  
3rd Business Division,  
17/F, Admiralty Centre, Tower 1  
18 Harcourt Road, Hong Kong  
Phone: (852) 28229311  
Fax: (852) 28660779  
www.sharp.com.hk

#### **Shenzhen Representative Office:**

Room 13B1, Tower C,  
Electronics Science & Technology Building  
Shen Nan Zhong Road  
Shenzhen, P.R. China  
Phone: (86) 755-3273731  
Fax: (86) 755-3273735