

Product Specification

SPECIFICATION FOR APPROVAL

- () Preliminary Specification
- (●) Final Specification



Title	4.0" (320 X RGB X 240) TFT – LCD
-------	-----------------------------------

BUYER	
MODEL	

SUPPLIER	LG Display Co., Ltd.
MODEL	LB040Q02
SUFFIX	TD05

SIGNATURE	DATE
/	_____
/	_____
/	_____

Please return 1 copy for your confirmation with your signature and comments.

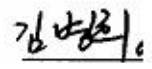
SIGNATURE	DATE
S. D. Jung / G.Manager	
REVIEWED BY	
J. Y. Kim/ Manager	
PREPARED BY	
B. H. Kim / Project Leader	
PREPARED BY	

**Products Engineering Dept.
LG Display Co., Ltd**

Product Specification

Contents

No	ITEM	Page
	COVER	1
	CONTENTS	2
	RECORD OF REVISIONS	3
1	SUMMARY	4
2	FEATURES	4
3	GENERAL SPECIFICATION	5
4	ABSOLUTE MAXIMUM RATINGS	5
5	ELECTRICAL SPECIFICATIONS	6
5-1	ELECTRICAL CHARACTERISTICS	6
5-2	INTERFACE CONNECTIONS	7
5-3	SIGNAL TIMING SPECIFICATIONS	10
5-4	SIGNAL TIMING WAVEFORMS	11
5-5	COLOR INPUT DATA REFERNECE	12
5-6	POWER SEQUENCE	13
5-7	VCC POWER DIP CONDITION	13
6	OPTICAL SPECIFICATIONS	14
7	MECHANICAL CHARACTERISTICS	18
8	RELIABILITY	21
9	INTERNATIONAL STANDARDS	22
9-1	SAFETY	22
9-2	EMC	22
10	PACKING	23
10-1	DESIGNATION OF LOT MARK	23
10-2	PACKING FORM	23
11	PRECAUTIONS	24

1. Summary

This module utilizes amorphous silicon thin film transistors. A 4.0" active matrix liquid crystal display allows full color to be displayed.

The applications are Car Navigation System, Amusement and others.

2. Features

- The 4.0" screen produces a high resolution image that is composed of 76,800 pixel elements in a stripe arrangement.
- Wide viewing angle technology is employed.
[The most suitable viewing direction is in the 6 o'clock direction.]
- By adopting an active matrix drive, a picture with high contrast is realized.
- A thin, light and compact module is accomplished through the use of COG mounting technology.
- By adopting a high aperture panel, high transmittance color filter and high transmission polarizing plates, transmittance ratio is realized.
- Gray scale or the brightness of the sub-pixel color is determined with a 6-bit gray scale signal.

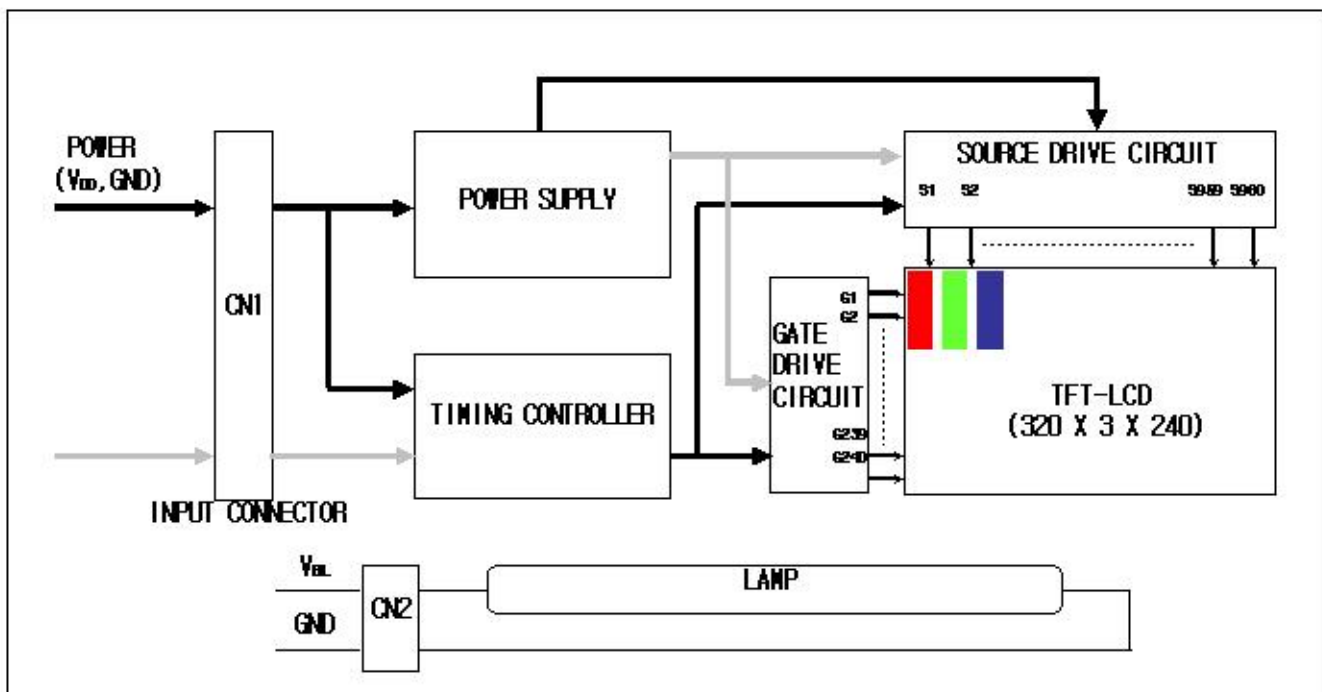

Product Specification

3. General Specification

CHARACTERISTIC ITEM	SPECIFICATION
Signal Interface	Digital Interface (CMOS TTL)
Display Mode	Normally White, Transmitting Type
Screen Size (Diagonal)	4.0" (102 mm)
Outline Dimension	98,4mm (H) X 78,0mm (V) X 10,4mm (D)
Active Area	81,6mm (H) X 61,2mm (V)
Number Of dots	320(H) X 3(R,G,B) X 240(V)
Color depth	6 Bit, 262,144 colors
Pixel Pitch	0,085mm(H) × RGB × 0,255mm(V)
Color Filter Array	RGB vertical stripes
Power Consumption	2,86 Watt(Typ)
Weight	110 g(Typ)
Backlight	CCFL (L Type, 1ea)
Surface Treatment	Top : WV-EA, AG Bottom : WV-EA, AG

4. Absolute Maximum Ratings

The following are maximum values which, if exceeded, may cause faulty operation or damage to the unit.

Table 1. ABSOLUTE MAXIMUM RATINGS

Parameter	Symbol	Values		Units	Notes
		Min	Max		
Power Input Voltage	VCC	-0.3	Vcc + 0.3	Vdc	at 25 ± 5°C
Operating Temperature	T _{OP}	-30	85	°C	4-1,2,3
Storage Temperature	T _{ST}	-40	85	°C	4-1,2

[Note 4-1] This rating applies to all parts of the module and should not be exceeded.

[Note 4-2] Maximum wet-bulb temperature is 60°C. Condensation of dew must be avoided as electrical current leaks will occur, causing a degradation of performance specifications.

[Note 4-3] The operating temperature only guarantees operation of the circuit and doesn't guarantee all the contents of Electro-optical specification.

[Note 4-4] This Module must be grounded between LCM and System.

5. Electrical Specifications

5-1. Electrical Characteristics

The LB040Q02 requires two power inputs. One is employed to power the LCD electronics and to drive the TFT array and liquid crystal. The second input which powers the CCFL, is typically generated by an inverter. The inverter is an external unit to the LCD.

Table 2. ELECTRICAL CHARACTERISTICS

Parameter	Symbol	Values			Unit	Notes
		Min	Typ	Max		
MODULE :						
Power Supply Input Voltage	VCC	3.0	3.3	3.6	Vdc	
Power Supply Input Current	I _{CC}	-	160	195	mA	*1
Power Consumption	P _c	-		0.65	Watt	*1
LAMP :						
Operating Voltage	V _{BL}	370	390	510	V _{RMS}	±10[%]
Operating Current	I _{BL}	3.0	6.0	6.5	mA _{RMS}	
Operating Frequency	f _{BL}	35	60	80	kHz	*2
Kick-Off Voltage (*4)	V _s	-	-	980	V _{RMS}	T _a =25°C
		-	-	1260	V _{RMS}	T _a =-0°C
Power Consumption	P _{BL}	-	2.34	2.57	Watt	at I _{BL} =TYP
Life Time		20,000	-	-	Hrs	*6

Note)

The design of the inverter must have specifications for the lamp in LCD Assembly. The performance of the Lamp in LCM, for example life time or brightness, is extremely influenced by the characteristics of the DC-AC inverter. So all the parameters of an inverter should be carefully designed so as not to produce too much leakage current from high-voltage output of the inverter. When you design or order the inverter, please make sure unwanted lighting caused by the mismatch of the lamp and the inverter(no lighting, flicker, etc) never occurs. When you confirm it, the LCD Assembly should be operated in the same condition as installed in your instrument.

- * 1. VCC=3.3V, 25°C, f_v (frame frequency) = 60Hz condition, whereas mosaic pattern(Typ), full black pattern(Max) is displayed. [LDO output voltage(3.3V) is applied.]
- * 2. This frequency range means the range to keep within ± 10% change of electrical and optical characteristics.
- * 3. This frequency range means not affecting to lamp life and reliability characteristics.
(The lamp frequency should be selected as different as possible from display horizontal synchronous signal (including harmonic frequency of this scanning frequency) to avoid "Beat" interference which may be observed on the screen as horizontal stripes like moving wave.)

Product Specification

This phenomenon is caused by interference between lamp (CCFL) lighting frequency and LCD horizontal synchronous signal.)

- * 4. The "MAX" of "Kick-Off Voltage" means the minimum voltage for inverter to turn on the CCFL normally in the LCD module. However this isn't the values that we can assure stability of starting lamp on condition that the module is installed in your set.
It should be careful that "Kick-Off Voltage" is changed by an increase of stray capacitance in your set, inverter method, value of ballast capacitor in your inverter and so on.
Especially, the value of "Kick-Off Voltage" is higher in low temperature condition than in normal temperature condition, because impedance of CCFL is increased.
The voltage above V_s should be applied to the lamps for more than 1 second for start-up.
Otherwise, the lamps may not be turned on. The used lamp current is the lamp typical current.
- * 5. The time needed to achieve not less than 95% brightness of the center part of lamp.
The brightness of the lamp after being lighted for 5 minutes is defined as 100%.
- * 6. "Life time" is defined as the time that the lamp brightness decreases to 50% from original brightness at $I_{BL}=TYP$; continuous lighting, $T_a=25^{\circ}C$.

Requirements for a system inverter design, which is intended to have a better display performance, a better power efficiency and a more reliable lamp, are as follows. It shall help increase the lamp lifetime and reduce leakage current. Inverter should be designed to be subject to the conditions below

- A. The asymmetry rate of the inverter waveform should be less than 10%.
- B. The distortion rate of the waveform should be within $\sqrt{2} \pm 10\%$.

* Inverter output waveform had better be more similar to ideal sine wave.

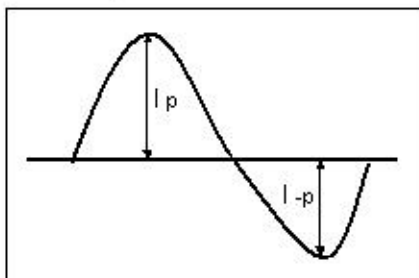

* Asymmetry rate:

$$(I_p - I_{-p}) / I_{rms} * 100\%$$

• Distortion rate:

$$I_p \text{ (or } I_{-p}) / I_{rms}$$

- C. There should not be any spikes in the waveform.
- D. Lamp current should not exceed the "MAX" value under the "Operating Temperature" (it is prohibited to exceed the "MAX." value even if it is operated in the guaranteed temperature).
When lamp current exceed the maximum value for a long time, it may cause a smoking and Ignition.
Therefore, it is recommended that the inverter have the current limited circuit that is used as a protection circuit and/or the lamp current-controlled inverter.

- * Do not attaches a conducting tape to lamp connecting wire.
If the lamp wire attach to a conducting tape, TFT-LCD Module has a low luminance and the inverter has abnormal action. Because leakage current is occurred between lamp wire and conducting tape.

5-2. Interface Connections

This LCD employs Two interface connections, a 40 pin connector is used for the module electronics interface and the other connectors is used for the integral backlight system.

The electronics interface connector is a model F100-S40B-C25 manufactured by UJU

Product Specification

Table 3. MODULE CONNECTOR PIN CONFIGURATION (CN1)

PIN	Name	Description	Comment
1	GND	Ground	
2	CLK	Main Clock	
3	GND	Ground	
4	GND	Ground	
5	R0	Red data (LSB)	
6	R1	Red data	
7	R2	Red data	
8	R3	Red data	
9	R4	Red data	
10	R5	Red data (MSB)	
11	GND	Ground	
12	GND	Ground	
13	G0	Green data (LSB)	
14	G1	Green data	
15	G2	Green data	
16	G3	Green data	
17	G4	Green data	
18	G5	Green data (MSB)	
19	GND	GND	
20	GND	GND	
21	B0	Blue data (LSB)	
22	B1	Blue data	
23	B2	Blue data	
24	B3	Blue data	
25	B4	Blue data	
26	B5	Blue data (MSB)	
27	GND	GND	
28	GND	GND	
29	HSYNC	Horizontal SYNC signal	[Note 3-1]
30	DE	Data Enable	
31	VSYNC	Vertical Sync signal	[Note 3-1]
32	GND	GND	
33	GND	GND	
34	NC	Not connect	
35	HVR	Horizontal, Vertical Revers	[Note 3-2]
36	GND	GND	
37	VCC	Main Power (3.3V)	
38	VCC	Main Power (3.3V)	
39	VCC	Main Power (3.3V)	
40	TC	Temp Sensor	

[Note 3-1] Hsync : Positive
 Vsync : Positive

[Note 3-2] "Low" : Regular video
 "High" : Horizontally and Vertically inverted video

Table 4. BACKLIGHT CONNECTOR PIN CONFIGURATION

Pin No.	SYMBOL	FUNCTION	REMARK
1	HV	Power Supply For Lamp [High Voltage Side]	1
2	LV	Power Supply For Lamp [Low Voltage Side]	2

The backlight interface connector is a model **BHSR-02VS-1** manufactured by JST or a compatible model manufactured by AMP. The matching connector part number is **SM02B-BHSS-1-TB** manufactured by JST or equivalent.

1. The wire color of high voltage side is pink.
2. The wire color of low voltage side is white. Connect the low voltage side of the DC/AC inverter used to drive the fluorescent tube to GND of the inverter circuit.

5-3. Signal Timing Specifications

Table 5. TIMING TABLE

ITEM		Symbol	MIN.	TYP.	MAX.	UNIT	NOTE
DCLK	Frequency	f_{CLK}	5	6.3	6.8	MHz	
Hsync	Period	t_{HP}	380	400	440	t_{CLK}	
	Sync_width	t_{WH}	20	30	40		
	Back Porch	t_{HBP}	20	25	40	t_{CLK}	
	Front Porch	t_{HFP}	20	25	40		
	Active Data	t_{HDE}	-	320	-	t_{CLK}	
Vsync	Period	t_{VP}	249	263	330	Line	For Hsync
	Sync_width	t_{WV}	2	7	30		
	Back Porch	t_{VBP}	5	10	30	Line	
	Front Porch	t_{VFP}	2	6	30		
	Active Data	t_{VDE}	-	240	-	Line	
DE	Horizontal Display Period	t_{HDE}	320	320	320	t_{CLK}	
	Vertical Display Period	t_{VDE}	240	240	240	Line	

Logic High : 0.7 X VCC

Logic Low : 0.3 X VCC

5-4. Signal Timing Waveforms [$V_{dd} = 3.3V$]

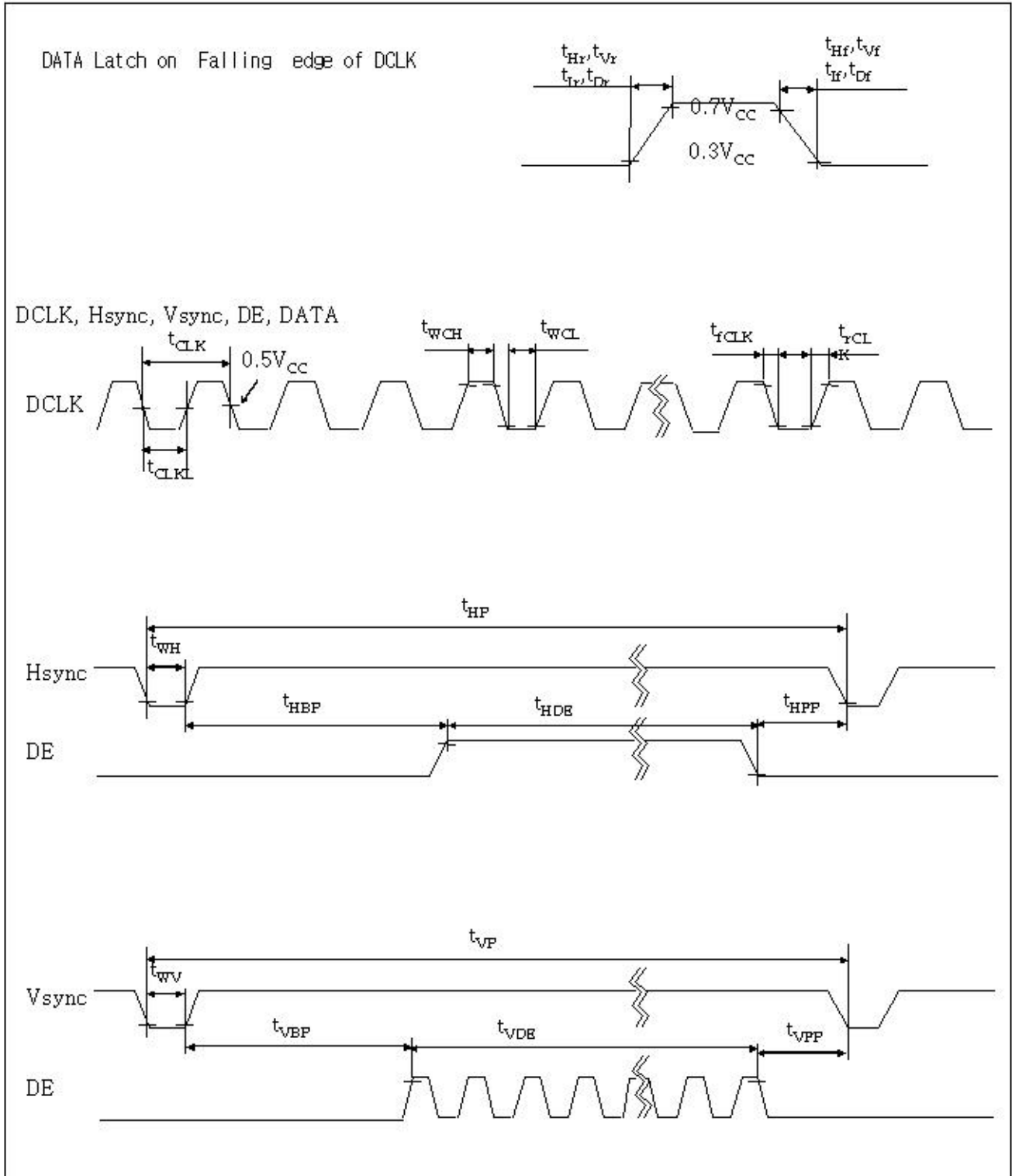

5-5. Color Input Data Reference

The brightness of each primary color (red, green and blue) is based on the 6-bit gray scale data input for the color ; the higher the binary input, the brighter the color. The table below provides a reference for color versus data input.

Table 6. COLOR DATA REFERENCE

Color		Input Color Data																	
		RED						GREEN						BLUE					
		MSB				LSB		MSB				LSB		MSB		LSB			
		R5	R4	R3	R2	R1	R0	G5	G4	G3	G2	G1	G0	B5	B4	B3	B2	B1	B0
Basic Color	Black	0	0	0	0	0	0	0	0	0	0	0	0	0	0	0	0	0	0
	Red	1	1	1	1	1	1	0	0	0	0	0	0	0	0	0	0	0	0
	Green	0	0	0	0	0	0	1	1	1	1	1	1	0	0	0	0	0	0
	Blue	0	0	0	0	0	0	0	0	0	0	0	0	1	1	1	1	1	1
	Cyan	0	0	0	0	0	0	1	1	1	1	1	1	1	1	1	1	1	1
	Magenta	1	1	1	1	1	1	0	0	0	0	0	0	1	1	1	1	1	1
	Yellow	1	1	1	1	1	1	1	1	1	1	1	1	0	0	0	0	0	0
	White	1	1	1	1	1	1	1	1	1	1	1	1	1	1	1	1	1	1
RED	RED (00)	0	0	0	0	0	0	0	0	0	0	0	0	0	0	0	0	0	0
	RED (01)	0	0	0	0	0	1	0	0	0	0	0	0	0	0	0	0	0	0
					
	RED (62)	1	1	1	1	1	0	0	0	0	0	0	0	0	0	0	0	0	0
	RED (63)	1	1	1	1	1	1	0	0	0	0	0	0	0	0	0	0	0	0
GREEN	GREEN (00)	0	0	0	0	0	0	0	0	0	0	0	0	0	0	0	0	0	0
	GREEN (01)	0	0	0	0	0	0	0	0	0	0	0	1	0	0	0	0	0	0
					
	GREEN (62)	0	0	0	0	0	0	1	1	1	1	1	0	0	0	0	0	0	0
	GREEN (63)	0	0	0	0	0	0	1	1	1	1	1	1	0	0	0	0	0	0
BLUE	BLUE (00)	0	0	0	0	0	0	0	0	0	0	0	0	0	0	0	0	0	0
	BLUE (01)	0	0	0	0	0	0	0	0	0	0	0	0	0	0	0	0	0	1
					
	BLUE (62)	0	0	0	0	0	0	0	0	0	0	0	0	1	1	1	1	1	0
	BLUE (63)	0	0	0	0	0	0	0	0	0	0	0	0	1	1	1	1	1	1

Product Specification

5-6. Power Sequence
Power supply for LCD (VCC)

Interface Signal (Tx)

Power for Lamp

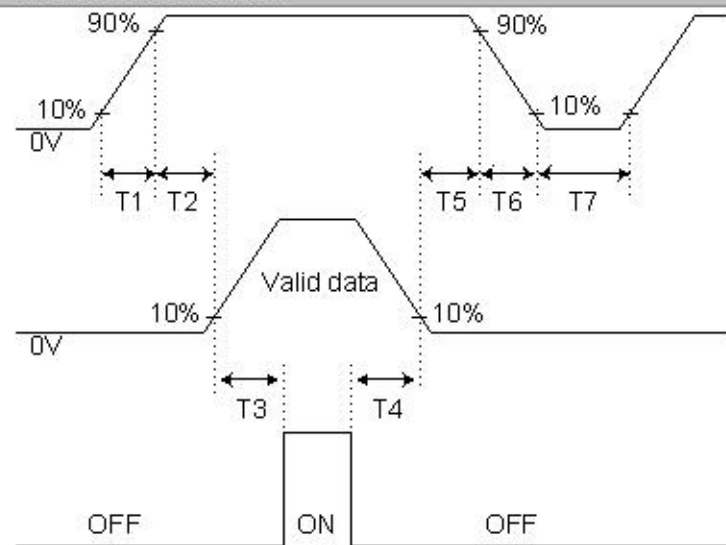

Table 7. POWER SEQUENCE TABLE

Parameter	Value			Units
	Min.	Typ.	Max.	
T ₁	-	-	10	(ms)
T ₂	0	-	50	(ms)
T ₃	200	-	-	(ms)
T ₄	200	-	-	(ms)
T ₅	0	-	50	(ms)
T ₆	0	-	10	(ms)
T ₇	2	-	-	(s)

Note)

1. Please avoid floating state of interface signal at invalid period.
2. When the interface signal is invalid, be sure to pull down the power supply for LCD VCC to 0V.

5.7 Vcc Power Dip Condition

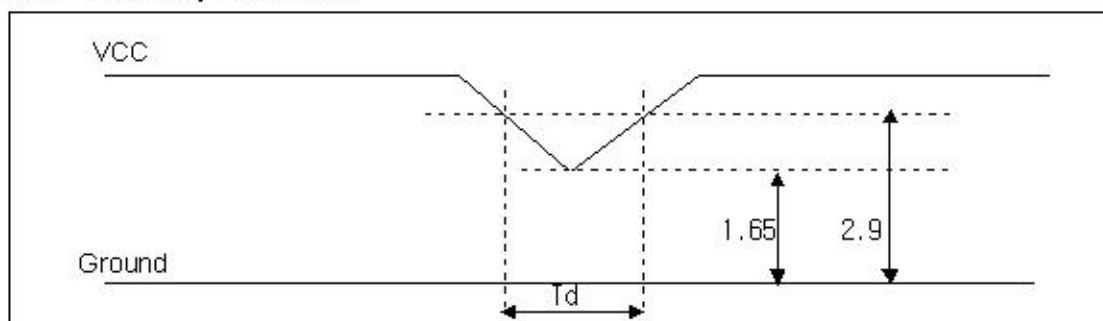

5.7.1 Dip Condition

$$1.65 \leq V_{cc} \leq 2.9, t_d \leq 20ms$$

5.7.2 Vcc < 1.65V

Vcc-dip Conditions should also follow the Power on/off condition for supply voltage

6. Optical Specification

Optical characteristics are determined after the unit has been 'ON' and stable for approximately 30 minutes in a dark environment at 25°C. The values specified are at an approximate distance 50cm from the LCD surface at a viewing angle of Φ and Θ equal to 0°.

FIG. 1 presents additional information concerning the measurement equipment and method.

FIG. 1 Optical Characteristic Measurement Equipment and Method

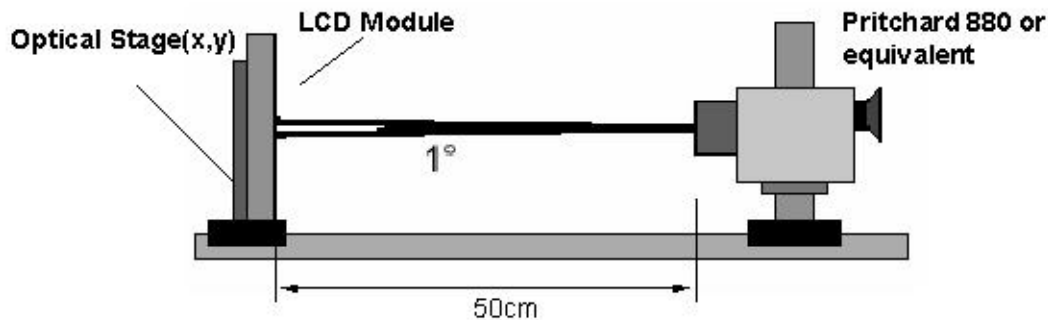

Table 8. OPTICAL CHARACTERISTICS

$T_a=25^\circ\text{C}$, $V_{CC}=3.3\text{V}$, $f_v=60\text{Hz}$, $D_{clk}=6.3\text{MHz}$, $I_e=6.0\text{mA}$

Parameter	Symbol	Values			Units	Notes
		Min	Typ	Max		
Contrast Ratio	CR	280	400	-	-	1
Surface Luminance, white	L_{WH}	360	450	-	cd/m ²	2
Luminance Variation	δ_{WHITE}	-	1.20	1.40	-	3
Response Time						4
Rise Time	T_{rR}	-	10	20	ms	
Decay Time	T_{rD}	-	30	45	ms	
Color Coordinates						
RED	RX	0.566	0.596	0.626		
	RY	0.317	0.347	0.377		
GREEN	GX	0.297	0.327	0.357		
	GY	0.512	0.542	0.572		
BLUE	BX	0.131	0.161	0.191		
	BY	0.116	0.146	0.176		
WHITE	WX	0.283	0.313	0.343		
	WY	0.299	0.329	0.359		
Viewing Angle						5 (CR \geq 10)
x axis, right($\Phi=0^\circ$)	Θ_r	60	70	-	degree	
x axis, left ($\Phi=180^\circ$)	Θ_l	60	70	-	degree	
y axis, up ($\Phi=90^\circ$)	Θ_u	40	50	-	degree	
y axis, down ($\Phi=270^\circ$)	Θ_d	50	60	-	degree	

Product Specification

Note)

1. Contrast Ratio(CR) is defined mathematically as

$$\text{Contrast Ratio} = \frac{\text{Surface Luminance with all white pixels}}{\text{Surface Luminance with all black pixels}}$$

2. Surface luminance is the center point across the LCD surface 50cm from the surface with all pixels displaying white. For more information see FIG 1.

3. The variation in surface luminance, The Panel total variation (
- δ_{WHITE}
-) is determined by measuring
- L_N
- at each test position 1 through 5, and then dividing the maximum
- L_N
- of 5 points luminance by minimum
- L_N
- of 5 points luminance. For more information see FIG 2.

$$\delta_{\text{WHITE}} = \text{Maximum}(L_1, L_2, \dots, L_5) / \text{Minimum}(L_1, L_2, \dots, L_5)$$

4. Response time is the time required for the display to transition from white to black (rise time,
- Tr_R
-) and from black to white(Decay Time,
- Tr_D
-). For additional information see FIG 3.

5. Viewing angle is the angle at which the contrast ratio is greater than 5. The angles are determined for the horizontal or x axis and the vertical or y axis with respect to the z axis which is normal to the LCD surface. For more information see FIG 4.

6. Gray scale specification

 * $f_v=60\text{Hz}$

Gray Level	Luminance [%] (Typ)
L0	0.15
L7	0.5
L15	3.5
L23	9.0
L31	19.0
L39	29.0
L47	45.0
L55	73.5
L63	100

FIG. 2 Luminance

<measuring point for surface luminance & measuring point for luminance variation>

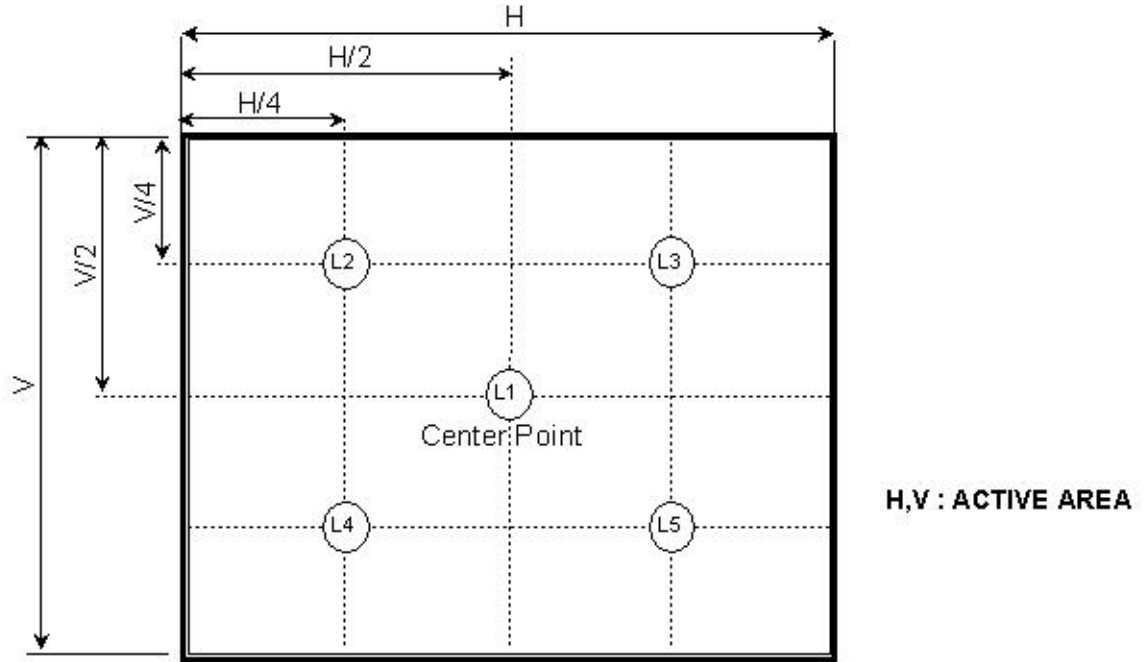

FIG. 3 Response Time

The response time is defined as the following figure and shall be measured by switching the input signal for "black" and "white".

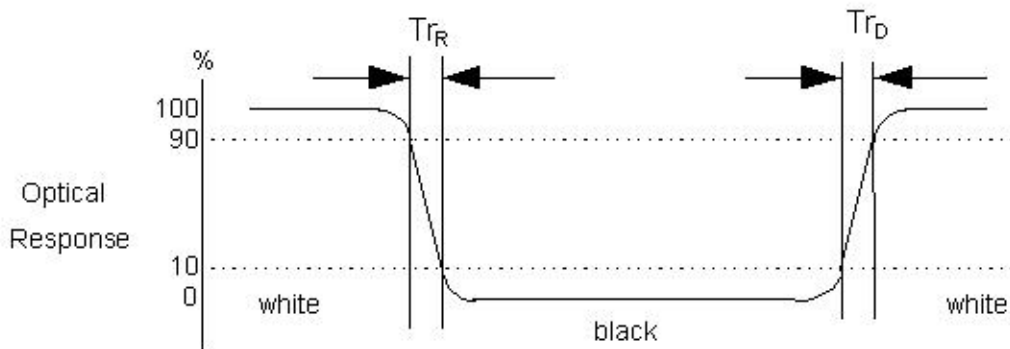
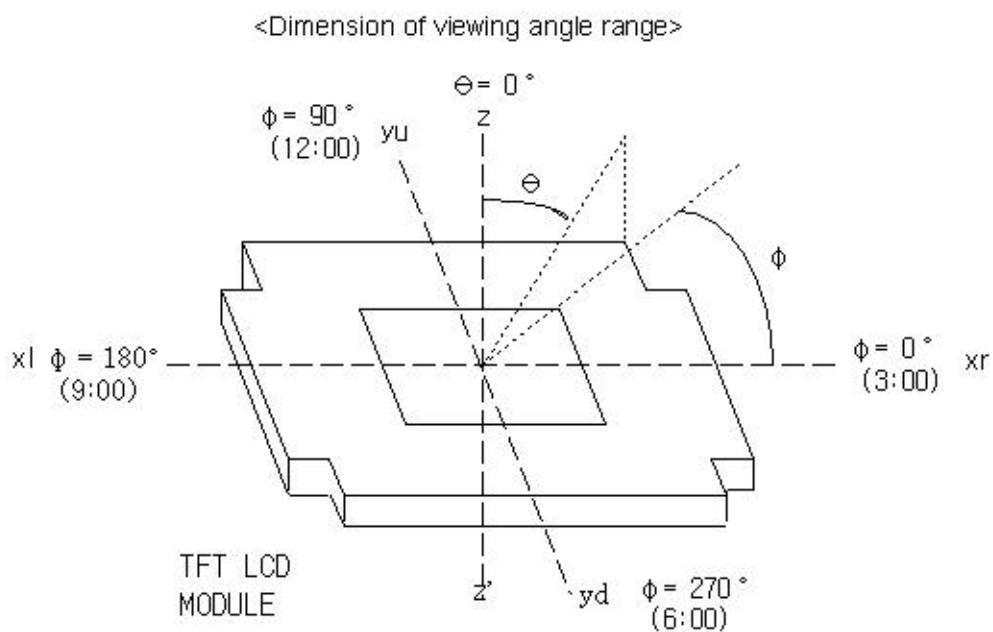

FIG. 4 Viewing angle



7. Mechanical Characteristics

The contents provide general mechanical characteristics for the model LB040Q02. In addition the figures in the next page are detailed mechanical drawing of the LCD.

Outline Dimension	Horizontal	98.4 (± 0.3)mm
	Vertical	78.0 (± 0.3)mm
	Depth	10.4 (± 0.3)mm
Active Display Area	Horizontal	81.6 mm
	Vertical	61.2 mm
Weight	110g (TYP), 120g(MAX)	

Product Specification

<FRONT VIEW>

Note) Unit: [mm], General tolerance: ± 0.5 mm

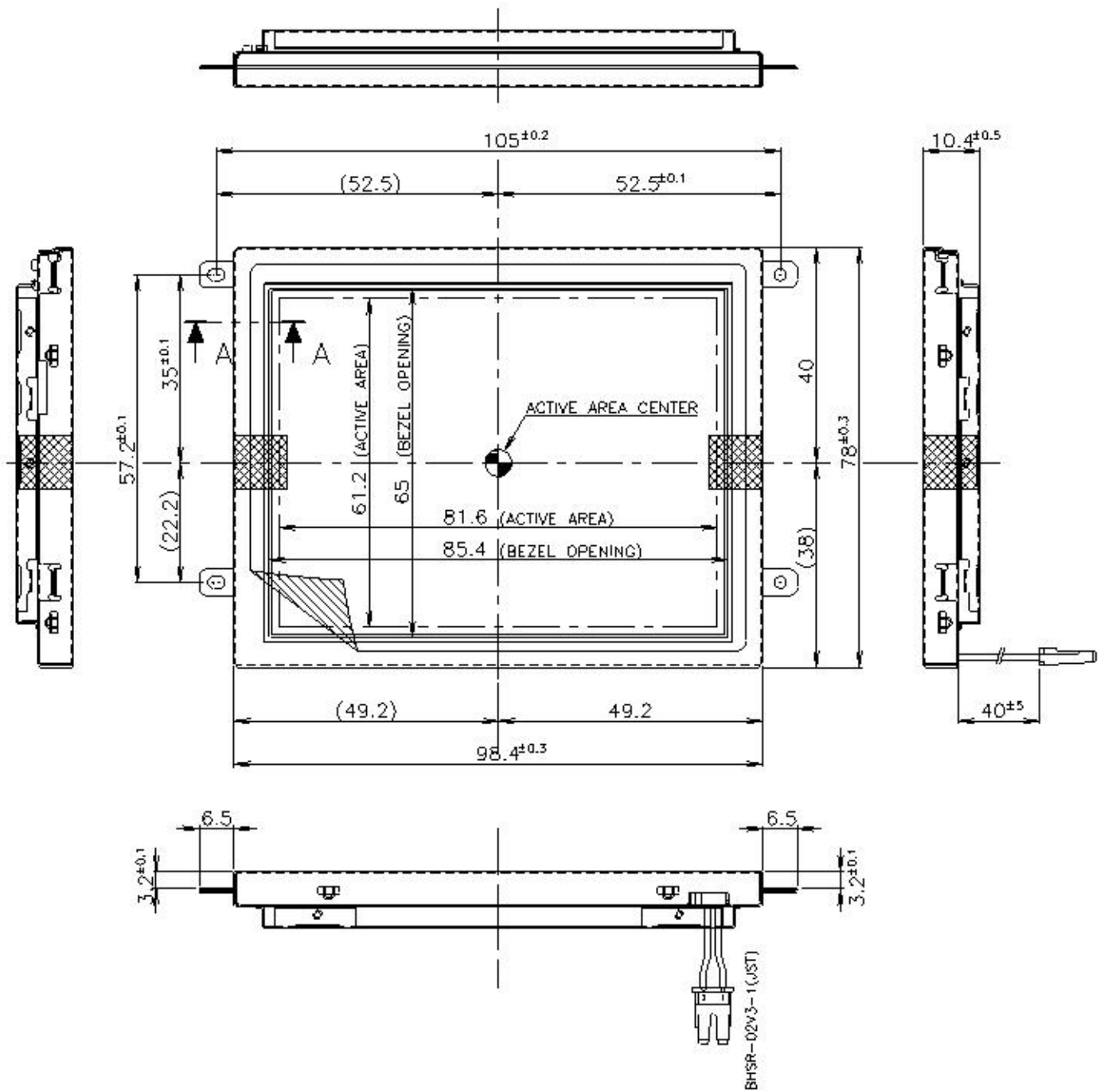

Product Specification

<REAR VIEW>

Note) Unit: [mm], General tolerance: $\pm 0.5\text{mm}$

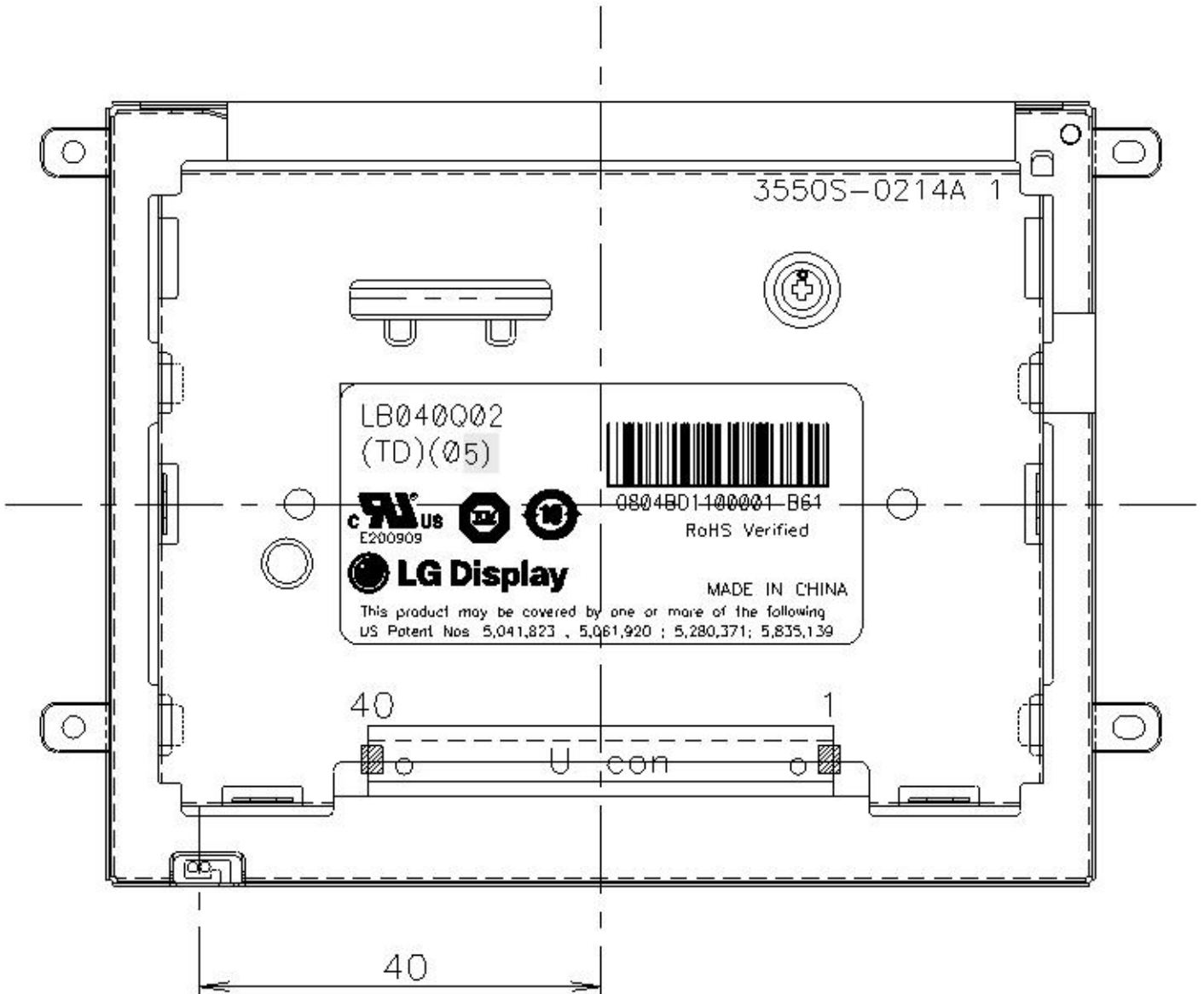

Product Specification

8. Reliability

No.	Test Items	Test Condition	REMARK
1	High Temperature Storage Test	Ta=85°C 240h	1
2	Low Temperature Storage Test	Ta=-40°C 240h	1
3	High Temperature Operation Test	Tp=85°C 240h	1
4	Low Temperature Operation Test	Ta=-30°C 240h	1
5	High Temperature and High Humidity Operation Test	Ta=65°C 90%RH 240h	1
6	Electro Static Discharge Test	-Panel Surface/Top_Case : 150pF ±15kV 150Ω (direct discharge, five times) -FPC input terminal : 100pF ±200V 0Ω	
7	Shock Test (non-operating)	No Operation, 180G, 2msec, Half Sine ±X, ±Y, ±Z Per 1time	
8	Vibration Test (non-operating)	Sine No Operation 10~500~10Hz, 0.37Oct/min, 1.5G X/Y/Z direction, Per 1H	
9	Thermal Shock Test	-30°C(0.5h) ~ 85°C(0.5h) / 100 cycles	1

***** Ta= Ambient Temperature, Tp = Panel Surface Temperature.

{ Result Evaluation Criteria }

1. Evaluation should be tested after storage at room temperature for 24 hours.
2. There should be no change which might affect the practical display function when the display quality test is conducted under normal operating condition.

9. International Standards

9-1. Safety

- a) UL 60950, Third Edition, Underwriters Laboratories, Inc., Dated Dec. 11, 2000.
Standard for Safety of Information Technology Equipment, Including Electrical Business Equipment.
- b) CAN/CSA C22.2, No. 60950, Third Edition, Canadian Standards Association, Dec. 1, 2000.
Standard for Safety of Information Technology Equipment, Including Electrical Business Equipment.
- c) EN 60950 : 2000, Third Edition
IEC 60950 : 1999, Third Edition
European Committee for Electro technical Standardization(CENELEC)
EUROPEAN STANDARD for Safety of Information Technology Equipment Including Electrical Business Equipment.

9-2. EMC

- a) ANSI C63.4 "Methods of Measurement of Radio-Noise Emissions from Low-Voltage Electrical and Electrical Equipment in the Range of 9kHz to 40GHz." American National Standards Institute(ANSI), 1992
- b) C.I.S.P.R "Limits and Methods of Measurement of Radio Interface Characteristics of Information Technology Equipment." International Special Committee on Radio Interference.
- c) EN 55022 "Limits and Methods of Measurement of Radio Interface Characteristics of Information Technology Equipment." European Committee for Electro technical Standardization.(CENELEC), 1998 (Including A1: 2000)

10. Packing

10-1. Designation of Lot Mark

a) Lot Mark

A	B	C	D	E	F	G	H	I	J	K	L	M
---	---	---	---	---	---	---	---	---	---	---	---	---

A,B,C : SIZE(INCH)
 E : MONTH

D : YEAR
 F ~ M : SERIAL NO.

Note

1. YEAR

Year	2001	2002	2003	2004	2005	2006	2007	2008	2009	2010
Mark	1	2	3	4	5	6	7	8	9	0

2. MONTH

Month	Jan	Feb	Mar	Apr	May	Jun	Jul	Aug	Sep	Oct	Nov	Dec
Mark	1	2	3	4	5	6	7	8	9	A	B	C

b) Location of Lot Mark

Serial No. is printed on the label. The label is attached to the backside of the LCD module.
 This is subject to change without prior notice.

10-2. Packing Form

a) Package quantity in one box : 132 pcs

b) Box Size : 475 x 348 x 341 (mm)

11. PRECAUTIONS

Please pay attention to the following when you use this TFT LCD module.

11-1. MOUNTING PRECAUTIONS

- (1) You must mount a module using holes arranged in four corners or four sides.
- (2) You should consider the mounting structure so that uneven force(ex. Twisted stress) is not applied to the module.
And the case on which a module is mounted should have sufficient strength so that external force is not transmitted directly to the module.
- (3) Please attach a transparent protective plate to the surface in order to protect the polarizer.
Transparent protective plate should have sufficient strength in order to resist external force.
- (4) You should adopt radiation structure to satisfy the temperature specification.
- (5) Acetic acid type and chlorine type materials for the cover case are not desirable because the former generates corrosive gas of attacking the polarizer at high temperature and the latter causes circuit break by electro-chemical reaction.
- (6) Do not touch, push or rub the exposed polarizers with glass, tweezers or anything harder than HB pencil lead. And please do not rub with dust clothes with chemical treatment.
Do not touch the surface of polarizer for bare hand or greasy cloth.(Some cosmetics deteriorate the polarizer.)
- (7) When the surface becomes dusty, please wipe gently with absorbent cotton or other soft materials like chamois soaks with petroleum benzene. Normal-hexane is recommended for cleaning the adhesives used to attach front / rear polarizers. Do not use acetone, toluene and alcohol because they cause chemical damage to the polarizer.
- (8) Wipe off saliva or water drops as soon as possible. Their long time contact with polarizer causes deformations and color fading.
- (9) Do not open the case because inside circuits do not have sufficient strength.
- (10) The metal case of a module should be contacted to electrical ground of your system.

11-2. OPERATING PRECAUTIONS

- (1) The spike noise causes the mis-operation of circuits. It should be lower than following voltage :
 $V = \pm 200\text{mV}$ (Over and under shoot voltage)
- (2) Response time depends on the temperature.(In lower temperature, it becomes longer.)
- (3) Brightness depends on the temperature. (In lower temperature, it becomes lower.)
And in lower temperature, response time(required time that brightness is stable after turned on) becomes longer.
- (4) Be careful for condensation at sudden temperature change. Condensation makes damage to polarizer or electrical contacted parts. And after fading condensation, smear or spot will occur.
- (5) When fixed patterns are displayed for a long time, remnant image is likely to occur.
- (6) Module has high frequency circuits. Sufficient suppression to the electromagnetic interference shall be done by system manufacturers. Grounding and shielding methods may be important to minimize the interference.

11-3. ELECTROSTATIC DISCHARGE CONTROL

Since a module is composed of electronic circuits, it is not strong to electrostatic discharge. Make certain that treatment persons are connected to ground through wrist band etc. And don't touch interface pin directly.

11-4. PRECAUTIONS FOR STRONG LIGHT EXPOSURE

Strong light exposure causes degradation of polarizer and color filter.

11-5. STORAGE

When storing modules as spares for a long time, the following precautions are necessary.

- (1) Store them in a dark place. Do not expose the module to sunlight or fluorescent light. Keep the temperature between 5°C and 35°C at normal humidity.
- (2) The polarizer surface should not come in contact with any other object.
It is recommended that they be stored in the container in which they were shipped.

11-6. HANDLING PRECAUTIONS FOR PROTECTION FILM

- (1) When the protection film is peeled off, static electricity is generated between the film and polarizer.
This should be peeled off slowly and carefully by people who are electrically grounded and with well ion-blown equipment or in such a condition, etc.
- (2) The protection film is attached to the polarizer with a small amount of glue. If some stress is applied to rub the protection film against the polarizer during the time you peel off the film, the glue is apt to remain on the polarizer.
Please carefully peel off the protection film without rubbing it against the polarizer.
- (3) When the module with protection film attached is stored for a long time, sometimes there remains a very small amount of glue still on the polarizer after the protection film is peeled off.
- (4) You can remove the glue easily. When the glue remains on the polarizer surface or its vestige is recognized, please wipe them off with absorbent cotton waste or other soft material like chamois soaked with normal-hexane.