



Contents

1. Operating Precautions	4
2. General Description	5
2.1 Display Characteristics	5
2.2 Optical Characteristics	6
3. Functional Block Diagram	9
4. Absolute Maximum Ratings	10
4. Absolute Maximum Ratings	10
4.1 Absolute Ratings of TFT LCD Module	10
4.2 Absolute Ratings of Environment	10
5. Electrical Characteristics	11
5.1 TFT LCD Module	11
5.2 Backlight Unit	13
5.2 Backlight Unit	13
6. Signal Characteristic	14
6.1 Pixel Format Image	14
6.2 Scanning Direction	14
6.3 Signal Description	15
6.4 The Input Data Format	16
6.5 Interface Timing.....	17
6.6 Power ON/OFF Sequence	17
6.6 Power ON/OFF Sequence	18
7. Connector & Pin Assignment	19
7.1 TFT LCD Module: Input Connector	19
7.2 Backlight Unit: Lamp Connector	19
7.3 Lamp Connector Pin Assignment	19
8. Reliability Test Criteria	20
9. Mechanical Characteristics	21
9.1 LCM Outline Dimension (Front View)	21
9.2 LCM Outline Dimension (Rear View).....	22
10. Label and Packaging	23
10.1 Shipping Label (on the rear side of TFT-LCD display)	23
10.2 Carton Label.....	23
11 Safety	24
11.1 Sharp Edge Requirements	24
11.2 Materials	24
11.3 Capacitors	24
11.4 National Test Lab Requirement	24



Record of Revision

Version and Date	Page	Old description	New Description
0.1 Apr. 09, 2007	All	First draft specification	-



1. Operating Precautions

- 1) Since front polarizer is easily damaged, please be cautious and not to scratch it.
- 2) Be sure to turn off power supply when inserting or disconnecting from input connector.
- 3) Wipe off water drop immediately. Long contact with water may cause discoloration or spots.
- 4) When the panel surface is soiled, wipe it with absorbent cotton or soft cloth.
- 5) Since the panel is made of glass, it may be broken or cracked if dropped or bumped on hard surface.
- 6) Since CMOS LSI is used in this module, take care of static electricity and insure human earth when handling.
- 7) Do not open nor modify the module assembly.
- 8) Do not press the reflector sheet at the back of the module to any direction.
- 9) In case if a module has to be put back into the packing container slot after it was taken out from the container, do not press the center of the CCFL Reflector edge. Instead, press at the far ends of the CCFL Reflector edge softly. Otherwise the TFT Module may be damaged.
- 10) At the insertion or removal of the Signal Interface Connector, be sure not to rotate nor tilt the Interface Connector of the TFT Module.
- 11) After installation of the TFT Module into an enclosure (Notebook PC Bezel, for example), do not twist nor bend the TFT Module even momentary. At designing the enclosure, it should be taken into consideration that no bending/twisting forces are applied to the TFT Module from outside. Otherwise the TFT Module may be damaged.
- 12) Cold cathode fluorescent lamp in LCD contains a small amount of mercury. Please follow local ordinances or regulations for disposal.
- 13) Small amount of materials having no flammability grade is used in the LCD module. The LCD module should be supplied by power complied with requirements of Limited Power Source (IEC60950 or UL1950), or be applied exemption.
- 14) The LCD module is designed so that the CCFL in it is supplied by Limited Current Circuit (IEC60950 or UL1950). Do not connect the CCFL in Hazardous Voltage Circuit.
- 15) Severe temperature condition may result in different luminance, response time and lamp ignition voltage.
- 16) Continuous operating TFT-LCD display under low temperature environment may accelerate lamp exhaustion and reduce luminance dramatically.
- 17) The data on this specification sheet is applicable when LCD module is placed in landscape position.
- 18) Continuous displaying fixed pattern may induce image sticking. It's recommended to use screen saver or shuffle content periodically if fixed pattern is displayed on the screen.



2. General Description

G104VN01 V0 is a Color Active Matrix Liquid Crystal Display composed of a TFT-LCD display, a driver circuit, and a backlight system. The screen format is intended to support VGA (640(H) x 480(V)) screen and 262K colors (RGB 6-bits). All input signals are TTL interface compatible. Inverter card of backlight is not included.

G104VN01 V0 is designed for industrial display applications.

2.1 Display Characteristics

The following items are characteristics summary on the table under 25 °C condition:

Items	Unit	Specifications
Screen Diagonal	[inch]	10.4
Active Area	[mm]	211.2(H) x 158.4(V)
Pixels H x V		640x3(RGB) x 480
Pixel Pitch	[mm]	0.33 x 0.33
Pixel Arrangement		R.G.B. Vertical Stripe
Display Mode		TN, Normally White
Nominal Input Voltage VDD	[Volt]	3.3V or 5V
Typical Power Consumption	[Watt]	6.7W (IRCFL=6.0mA) All black pattern
Weight	[Grams]	490g(typ.)
Physical Size	[mm]	243.0(H)x 176.6(V) x 11.5(D)
Electrical Interface		1ch TTL
Surface Treatment		Anti-glare, Hardness 3H
Support Color		262K colors
Temperature Range Operating	[°C]	-30 to +80
Storage (Non-Operating)	[°C]	-30 to +80
RoHS Compliance		RoHS Compliance

2.2 Optical Characteristics

The optical characteristics are measured under stable conditions at 25 °C (Room Temperature):

Item	Unit	Conditions	Min.	Typ.	Max.	Note
White Luminance	[cd/m ²]	IRCFL= 6mA (center point)		450	-	1
Uniformity	%	5 points	75		-	1, 2, 3
Contrast Ratio				500	-	4
Response Time	[msec]	Rising	-	10	20	5
	[msec]	Falling	-	25	30	
	[msec]	Rising + Falling	-	35	50	
Viewing Angle	[degree]	Horizontal (Right) CR = 10 (Left)	65	70	-	6
	[degree]		65	70	-	
	[degree]	Vertical (Upper) CR = 10 (Lower)	50	55	-	
	[degree]		60	65	-	
Color / Chromaticity Coordinates (CIE 1931)		Red x	TBD	TBD	TBD	
		Red y	TBD	TBD	TBD	
		Green x	TBD	TBD	TBD	
		Green y	TBD	TBD	TBD	
		Blue x	TBD	TBD	TBD	
		Blue y	TBD	TBD	TBD	
		White x	0.28	0.31	0.34	
		White y	0.30	0.33	0.36	
Color Gamut	%			TBD	-	

Note 1: Measurement method

Equipment Pattern Generator, Power Supply, Digital Voltmeter, Luminance meter (SR_3 or equivalent)

Aperture 1° with 50cm viewing distance

Test Point Center

Environment < 1 lux

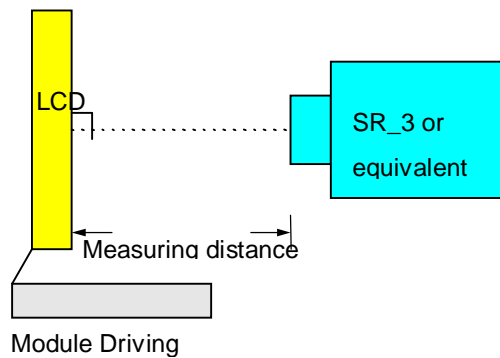

Note 2: Definition of 5 points position (Display active area: 211.2mm (H) x 158.4mm (V))

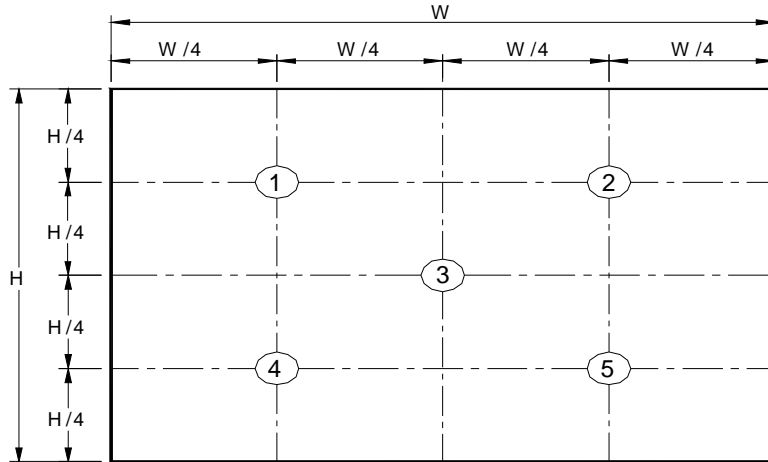

Note 3: The luminance uniformity of 5 points is defined by dividing the minimum luminance values by the maximum test point luminance

$$\delta_{w5} = \frac{\text{Minimum Brightness of five points}}{\text{Maximum Brightness of five points}}$$

Note 4: Definition of contrast ratio (CR):

$$\text{Contrast ratio (CR)} = \frac{\text{Brightness on the "White" state}}{\text{Brightness on the "Black" state}}$$

Note 5: Definition of response time:

The output signals of photo detector are measured when the input signals are changed from "White" to "Black" (falling time) and from "Black" to "White" (rising time), respectively. The response time interval is between 10% and 90% of amplitudes. Please refer to the figure as below.

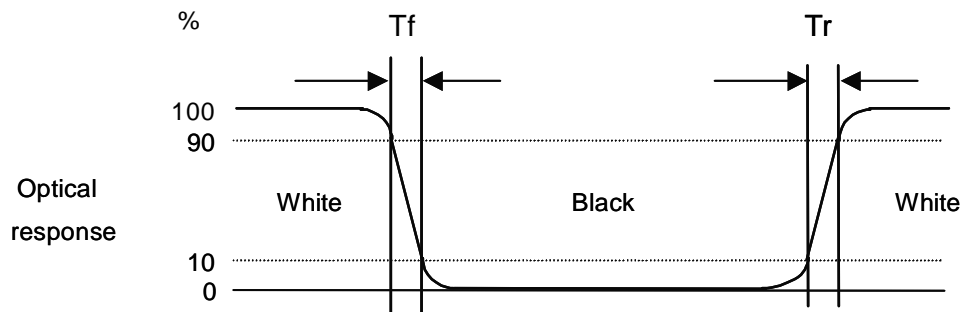

Note 6: Definition of viewing angle

Viewing angle is the measurement of contrast ratio ≥ 10 , at the screen center, over a 180° horizontal and 180° vertical range (off-normal viewing angles). The 180° viewing angle range is broken down as below: 90° (θ) horizontal left and right, and 90° (Φ) vertical high (up) and low (down). The measurement direction is typically perpendicular to the display surface with the screen rotated to its center to develop the desired measurement viewing angle.

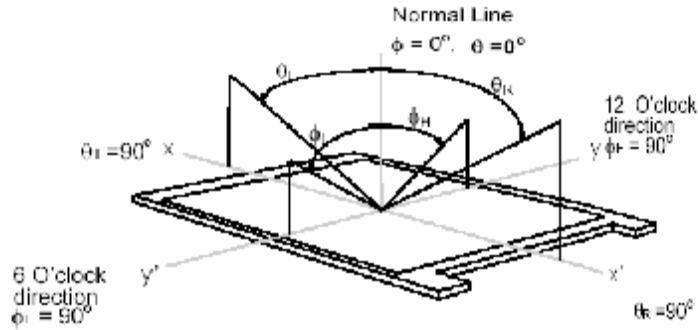

3. Functional Block Diagram

The following diagram shows the functional block of the 10.4 inch color TFT/LCD module:

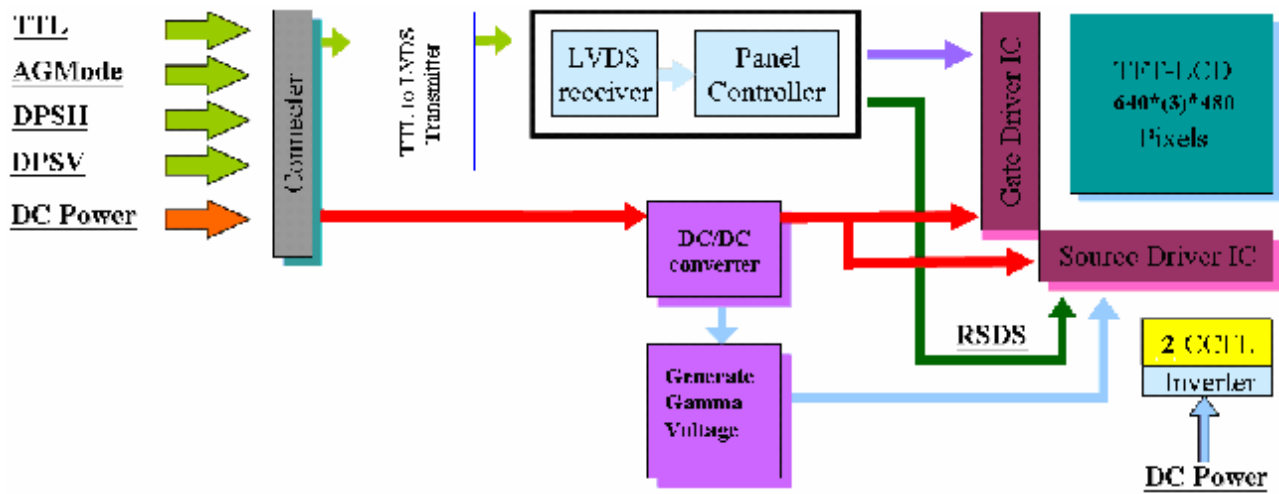



4. Absolute Maximum Ratings

4.1 Absolute Ratings of TFT LCD Module

Item	Symbol	Min	Max	Unit
Logic Voltage	Vin	-0.3	VDD+0.3	[Volt]
Supply Voltage	VDD	0	5.5	[Volt]

4.2 Absolute Ratings of Environment

Item	Symbol	Min	Max	Unit
Operating Temperature	TOP	-30	+80	[°C]
Operation Humidity	HOP	5	90	[%RH]
Storage Temperature	TST	-30	+80	[°C]
Storage Humidity	HST	5	90	[%RH]

Note: Maximum Wet-Bulb should be 39 °C and no condensation.

5. Electrical Characteristics

5.1 TFT LCD Module

5.1.1 Power Specification

Symbol	Parameter	Min	Typ	Max	Units	Remark
VDD	Logic/LCD Drive Voltage	3.0	3.3	3.6	[Volt]	
		4.5	5.0	5.5		
IDD	VDD Current	-	220	240	[mA]	All Black Pattern(VDD=3.3V)
		-	144	160		All Black Pattern(VDD=5V)
Irush	LCD Inrush Current	-	-	0.9	[A]	Note 1
PDD	VDD Power	-	0.73	0.8	[Watt]	All Black Pattern(VDD=3.3V)
		-	0.73	0.8		All Black Pattern(VDD=5V)
VDDrp	Allowable Logic/LCD Drive Ripple Voltage	-	-	100	[mV] p-p	All Black Pattern (VDD=3.3V/5V)

Note 1: Irush current measurement condition when LCD supplies 3.3V:

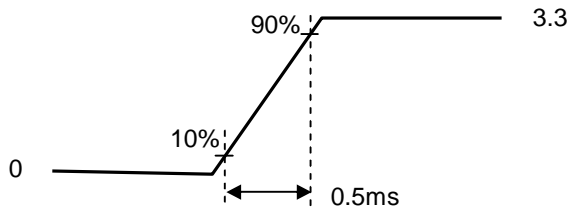
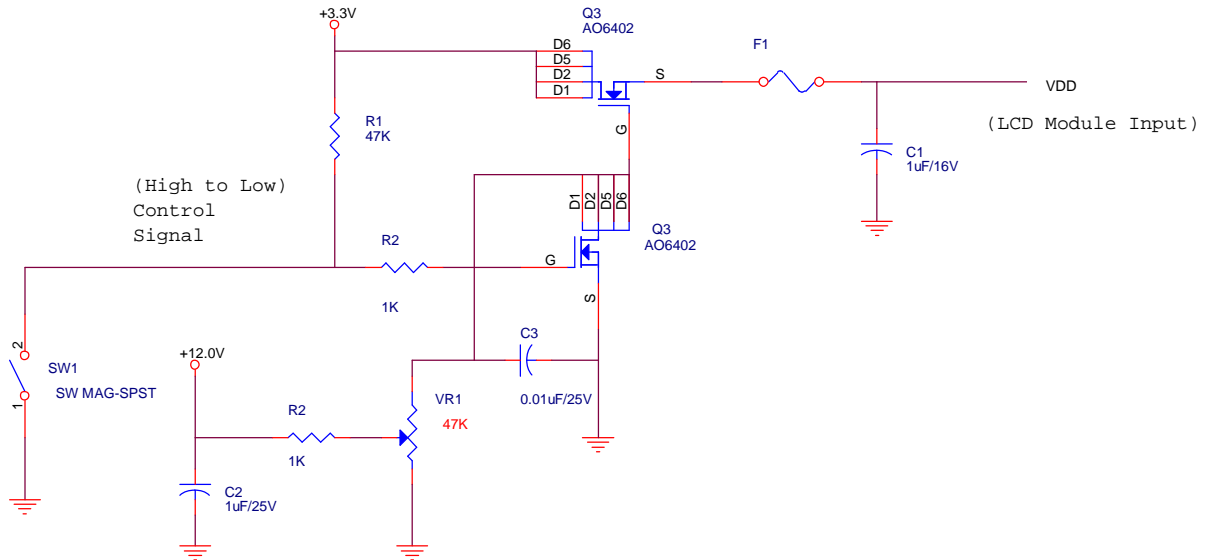

VDD rising time



5.1.2 Signal Electrical Characteristics

Input signals shall be low or Hi-Z state when VDD is off.

Symbol	Item	Min.	Typ.	Max.	Unit	Remark
VIH	High Input Voltage	0.7VDD	-	VDD	[Volt]	
VIL	Low Input Voltage	-	-	0.3VDD	[Volt]	

5.2 Backlight Unit

5.2.1 Parameter guideline for CCFL

Following characteristics are measured under a stable condition using an inverter at 25 °C (Room Temperature):

Symbol	Parameter	Min.	Typ.	Max.	Unit	Remark
IRCFL	CCFL operation range	4.5	6.0	7.0	[mA] rms	(Ta=25°C) Note 1, 2
FCFL	CCFL Frequency	40	50	60	[KHz]	(Ta=25°C) Note 3
ViCFL (25°C) (reference)	CCFL Ignition Voltage	-	-	TBD	[Volt] rms	(Ta=25°C)
VCFL	CCFL Discharge Voltage	440	490	540	[Volt] rms	(Ta=25°C) Note 4 IRCFL=6mA
PCFL	CCFL Power consumption (inverter excluded)	-	5.88	-	[Watt]	(Ta=25°C) Note 4 IRCFL=6mA
Lamp Life			50,000		Hrs	(Ta=25°C) Note 2 IRCFL= 6mA

Note 1: IRCFL is defined as the return current of an inverter. (In Figure. 1)

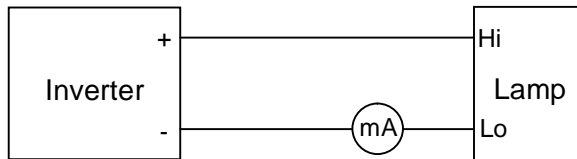

(Figure. 1: Measurement of return current)

A stable IRCFL is a current without flicker or biasing waveform provided by inverter that ensures the backlight perform to its specification. The ideal sine waveform should be symmetric in positive and negative polarities and the asymmetry rate of the inverter waveform should be below 10%.

It is recommended to use the inverter with detection circuit to avoid overvoltage, overcurrent, or mismatching waveform. The purpose is to avoid current flow into only one of the lamps when the other one is not in operation.

Note 2: The definition of lamp life means when any of following conditions happen:

- Luminance falls to 50% or less of the initial value.
- Normal lighting is no more available (flickering, pink lighting, no lighting, etc.)
- Lamp voltage or lighting start voltage exceeds the specified value.

Note 3: CCFL frequency should be carefully determined to avoid interference between inverter and TFT LCD.

Higher frequency will induce higher leakage current and further impact lamp life.

Note 4: Calculator value for reference (IRCFLxVCFLx2=PCFL).

Note 5: The display is with dual lamp design, and the CCFL current in above table refers to each lamp

6. Signal Characteristic

6.1 Pixel Format Image

Following figure shows the relationship between input signal and LCD pixel format.

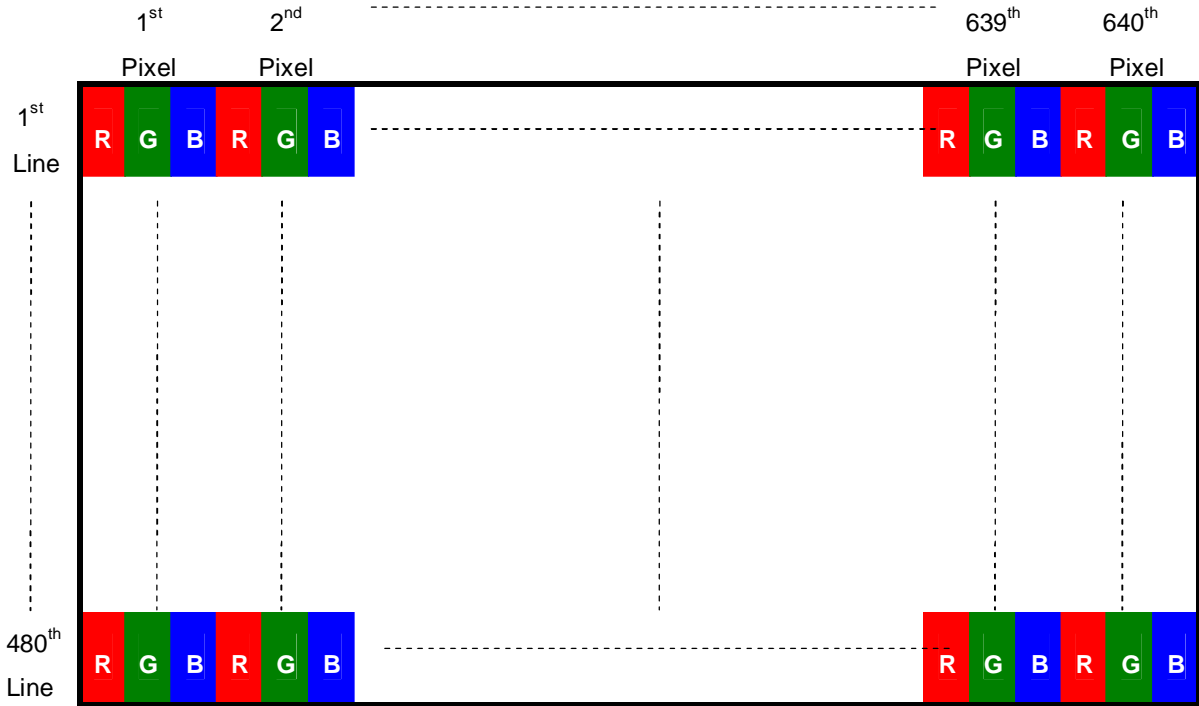

6.2 Scanning Direction

The following figures show the image seen from the front view. The arrow indicates the direction of scan.



Fig. 1 Normal scan (DPSH = High, DPSV=Low)



Fig. 2 Reverse scan (DPSH = Low/NC, DPSV=Low)



Fig. 3 Reverse scan (DPSH = High, DPSV=High)



Fig. 4 Reverse scan (DPSH = Low, DPSV=High)



6.3 Signal Description

Pin no	Symbol	Function	Etc.
1	GND	Ground	
2	CK	Clock signal for sampling each data signal	
3	Hsync	Horizontal synchronous signal	
4	Vsync	Vertical synchronous signal	
5	GND	Ground	
6	R0	RED data signal(LSB)	
7	R1	RED data signal	
8	R2	RED data signal	
9	R3	RED data signal	
10	R4	RED data signal	
11	R5	RED data signal (MSB)	
12	GND	Ground	
13	G0	GREEN data signal (LSB)	
14	G1	GREEN data signal	
15	G2	GREEN data signal	
16	G3	GREEN data signal	
17	G4	GREEN data signal	
18	G5	GREEN data signal (MSB)	
19	GND	Ground	
20	B0	BLUE data signal (LSB)	
21	B1	BLUE data signal	
22	B2	BLUE data signal	
23	B3	BLUE data signal	
24	B4	BLUE data signal	
25	B5	BLUE data signal(MSB)	
26	GND	Ground	
27	ENAB	Signal to settle the horizontal display position	
28	VDD	+3.3V / +5.0V power supply	
29	VDD	+3.3V / +5.0V power supply	
30	DPSH	Horizontal reverse scan control signal	
31	DPSV	Vertical reverse scan control signal	



6.4 The Input Data Format

	Colors & Gray scale	Data signal																		
		Gray Scale	R0	R1	R2	R3	R4	R5	G0	G1	G2	G3	G4	G5	B0	B1	B2	B3	B4	B5
Basic Color	Black	—	0	0	0	0	0	0	0	0	0	0	0	0	0	0	0	0	0	0
	Blue	—	0	0	0	0	0	0	0	0	0	0	0	0	1	1	1	1	1	1
	Green	—	0	0	0	0	0	0	1	1	1	1	1	1	0	0	0	0	0	0
	Cyan	—	0	0	0	0	0	0	1	1	1	1	1	1	1	1	1	1	1	1
	Red	—	1	1	1	1	1	1	0	0	0	0	0	0	0	0	0	0	0	0
	Magenta	—	1	1	1	1	1	1	0	0	0	0	0	0	1	1	1	1	1	1
	Yellow	—	1	1	1	1	1	1	1	1	1	1	1	1	0	0	0	0	0	0
	White	—	1	1	1	1	1	1	1	1	1	1	1	1	1	1	1	1	1	1
Gray Scale of Red	Black	GS0	0	0	0	0	0	0	0	0	0	0	0	0	0	0	0	0	0	0
	↑	GS1	1	0	0	0	0	0	0	0	0	0	0	0	0	0	0	0	0	0
	Darker	GS2	0	1	0	0	0	0	0	0	0	0	0	0	0	0	0	0	0	0
	↑	↓			↓					↓						↓				
	↓	↓			↓					↓						↓				
	Brighter	GS61	1	0	1	1	1	1	0	0	0	0	0	0	0	0	0	0	0	0
	↓	GS62	0	1	1	1	1	1	0	0	0	0	0	0	0	0	0	0	0	0
	Red	GS63	1	1	1	1	1	1	0	0	0	0	0	0	0	0	0	0	0	0
Gray Scale of Green	Black	GS0	0	0	0	0	0	0	0	0	0	0	0	0	0	0	0	0	0	0
	↑	GS1	0	0	0	0	0	0	1	0	0	0	0	0	0	0	0	0	0	0
	Darker	GS2	0	0	0	0	0	0	0	1	0	0	0	0	0	0	0	0	0	0
	↑	↓			↓					↓						↓				
	↓	↓			↓					↓						↓				
	Brighter	GS61	0	0	0	0	0	0	1	0	1	1	1	1	0	0	0	0	0	0
	↓	GS62	0	0	0	0	0	0	0	1	1	1	1	1	0	0	0	0	0	0
	Green	GS63	0	0	0	0	0	0	1	1	1	1	1	1	0	0	0	0	0	0
Gray Scale of Blue	Black	GS0	0	0	0	0	0	0	0	0	0	0	0	0	0	0	0	0	0	0
	↑	GS1	0	0	0	0	0	0	0	0	0	0	0	0	1	0	0	0	0	0
	Darker	GS2	0	0	0	0	0	0	0	0	0	0	0	0	0	1	0	0	0	0
	↑	↓			↓					↓						↓				
	↓	↓			↓					↓						↓				
	Brighter	GS61	0	0	0	0	0	0	0	0	0	0	0	0	1	0	1	1	1	1
	↓	GS62	0	0	0	0	0	0	0	0	0	0	0	0	0	1	1	1	1	1
	Blue	GS63	0	0	0	0	0	0	0	0	0	0	0	0	1	1	1	1	1	1

0 : Low level voltage, 1 : High level voltage

6.5 Interface Timing

6.5.1 Timing Characteristics

Signal	Parameter	Symbol	Min.	Typ.	Max.	Unit	Remark	
Clock Timing	Clock Frequency	$1/T_{\text{Clock}}$	20	25.2	40	MHz	Note1, Note2	
Vsync Timing	Vertical Section	Period	T_V	520	525	622	T_{Line}	Note1, Note2
		Active	T_{VD}	480	480	480		
		Blanking	T_{VB}	40	45	142		
Hsync Timing	Horizontal Section	Period	T_H	770	800	1070	T_{Clock}	Note1, Note2
		Active	T_{HD}	640	640	640		
		Blanking	T_{HB}	130	160	430		

Note 1: Frame rate is 60 Hz

Note 2: DE mode

6.5.2 Input Timing Diagram

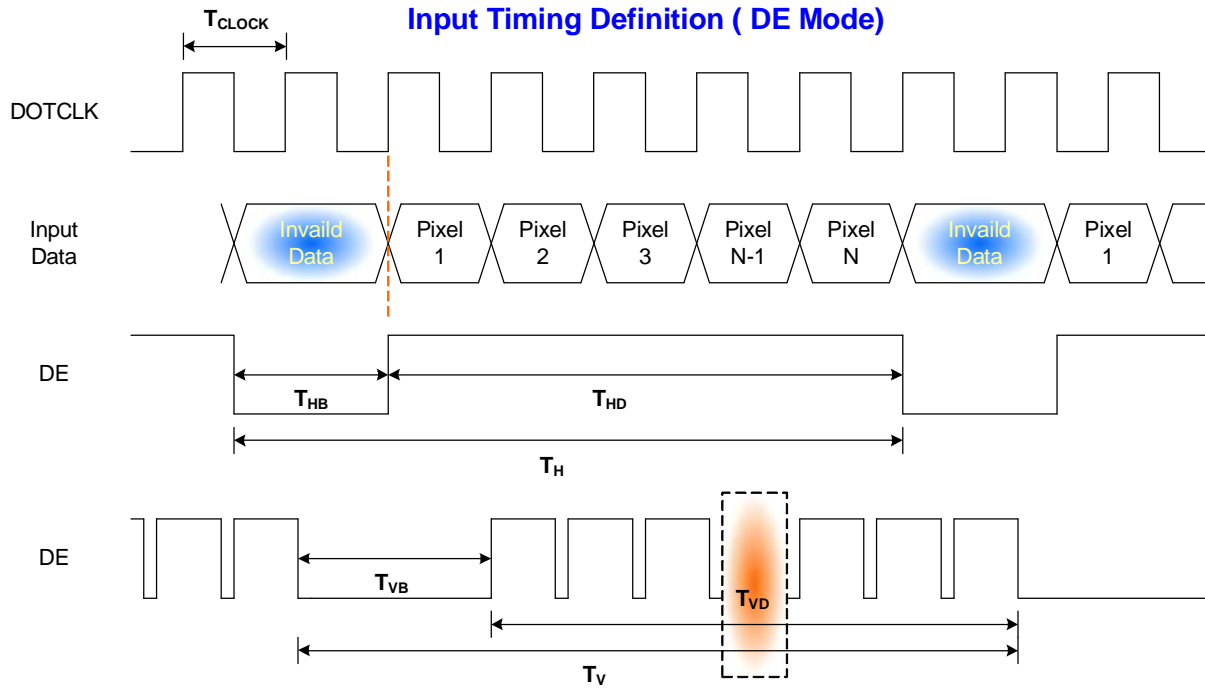

6.6 Power ON/OFF Sequence

VDD power and lamp on/off sequence is as below. Interface signals are also shown in the chart. Signals from any system shall be Hi-Z state or low level when VDD is off.

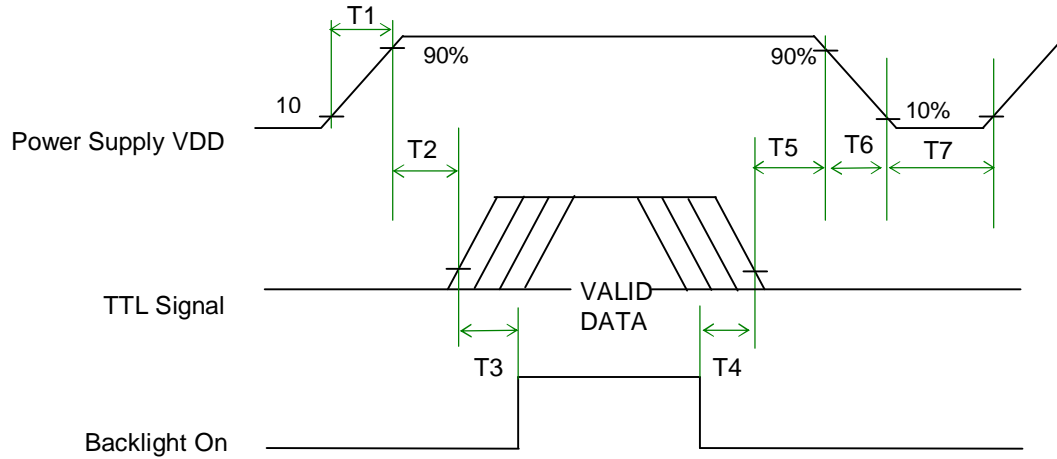

Power ON/OFF sequence timing

Parameter	Value			Units
	Min.	Typ.	Max.	
T1	0.5	-	10	ms
T2	0	-	50	ms
T3	180	-	-	ms
T4	180	-	-	ms
T5	0	-	50	ms
T6	0	-	10	ms
T7	500	-	-	ms

The above on/off sequence should be applied to avoid abnormal function in the display. Please make sure to turn off the power when you plug the cable into the input connector or pull the cable out of the connector.



7. Connector & Pin Assignment

Physical interface is described as for the connector on module. These connectors are capable of accommodating the following signals and will be following components.

7.1 TFT LCD Module: Input Connector

Connector Name / Designation	Signal Connector
Manufacturer	Hirose or compatible
Connector Model Number	HRS DF9B-31P-1V or compatible
Adaptable Plug	HRS DF9B-31S-1V or compatible

7.2 Backlight Unit: Lamp Connector

Connector Name / Designation	Lamp Connector
Manufacturer	JST or compatible
Connector Model Number	BHS-03VS-1 or compatible
Mating Model Number	B-BHS-1-TB or compatible

7.3 Lamp Connector Pin Assignment

CN2 connector (backlight): BHS-03VS-1

Pin #	Symbol	Cable color	Signal Name
1	H	Pink	CCFL power supply(H.V.)
2	NC		No connection
3	L	White	CCFL power supply(GND)

Pin #	Symbol	Cable color	Signal Name
1	H	Blue	CCFL power supply(H.V.)
2	NC		No connection
3	L	Black	CCFL power supply(GND)



8. Reliability Test Criteria

Items	Required Condition	Note
Temperature Humidity Bias	40°C/90%,300Hr	
High Temperature Operation	80°C,300 hours (center point of panel surface)	
Low Temperature Operation	-30°C,300 hours	
Hot Storage	80 °C,300 hours	
Cold Storage	-30 °C,300 hours	
Thermal Shock Test	-30 °C /30 min ,80 °C /30 min ,100cycles, 40 °C minimun ramp rate	
Hot Start Test	80 °C /1 Hr min. power on/off per 5 minutes, 5 times	
Cold Start Test	-30 °C /1 Hr min. power on/off per 5 minutes, 5 times	
Shock Test (Non-Operating)	50G,20ms,Half-sine wave,(+-X,+-Y,+Z)	
Vibration Test (Non-Operating)	1.5G, 10~200~10Hz, Sine wave 30mins/axis, 3 direction (X, Y, Z)	
On/off test	On/10 sec, Off/10 sec, 30,000 cycles	
ESD	Contact : ± 8KV/ operation, Class B Air : ± 15KV / operation, Class B	Note 1
EMI	30-230 MHz, limit 40 dBu V/m, 230-1000 MHz, limit 47 dBu V/m	

Note1: According to EN61000-4-2 , ESD class B: Some performance degradation allowed. No data lost . Self-recoverable. No hardware failures.

9.2 LCM Outline Dimension (Rear View)

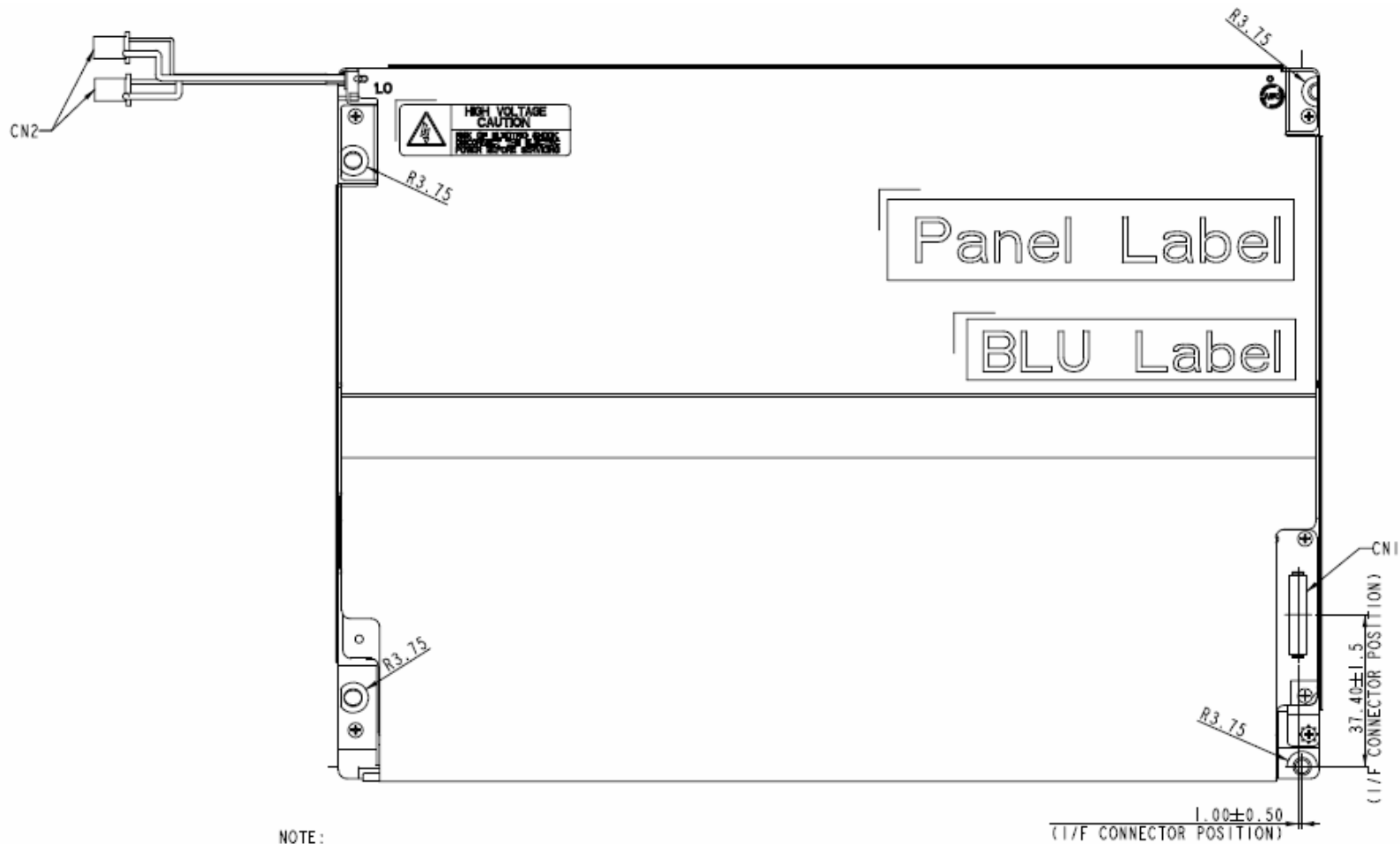

NOTE:
 1. CN1: THE INTERFACE CONNECTOR IS B-BHS-1-TB.
 2. CN2: THE LAMP CONNECTOR IS JST BHR-03VS-1.
 3. TOLERANCE IS $\pm 0.5\text{mm}$ IF NOT SPECIFIED.

CN2 NO.	ELECTRODE	REMARK
1	HIGH VOLTAGE	PINK, BLUE
2	DUMMY	
3	LOW VOLTAGE	WHITE, BLACK



10. Label and Packaging

10.1 Shipping Label (on the rear side of TFT-LCD display)

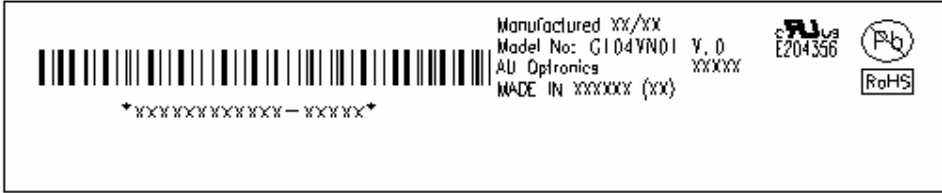

10.2 Carton Label

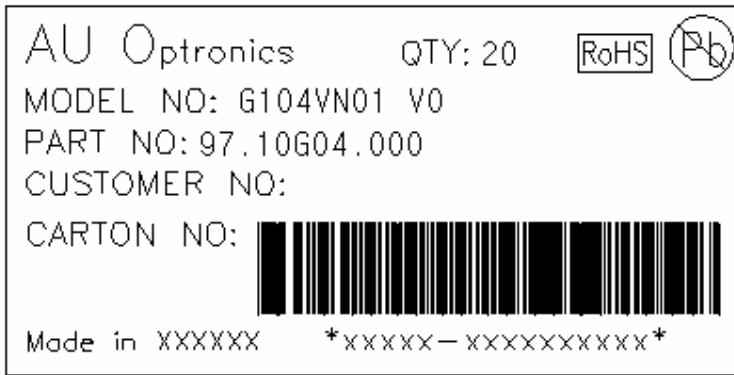



11 Safety

11.1 Sharp Edge Requirements

There will be no sharp edges or comers on the display assembly that could cause injury.

11.2 Materials

Toxicity

There will be no carcinogenic materials used anywhere in the display module. If toxic materials are used, they will be reviewed and approved by the responsible AUO toxicologist.

11.3 Capacitors

If any polarized capacitors are used in the display assembly, provisions will be made to keep them from being inserted backwards.

11.4 National Test Lab Requirement

The display module will satisfy all requirements for compliance to:

UL 60950

U.S.A. Information Technology Equipment