



( ) Preliminary Specifications  
(V) Final Specifications

<b>Module</b>	6.5 Inch Color TFT-LCD
<b>Model Name</b>	G065VN01 V1

www.millotech.com

Customer	Date
_____	_____
<b>Checked &amp; Approved by</b>	
_____	_____
Note: This Specification is subject to change without notice.	

Approved by	Date
<u>Debbie Chiu</u>	<u>2008/03/07</u>
<b>Prepared by</b>	
<u>David Hsing</u>	<u>2008/03/07</u>
General Display Business Division / AU Optronics corporation	

## Contents

<b>1. Operating Precautions .....</b>	<b>4</b>
<b>2. General Description .....</b>	<b>5</b>
2.1 Display Characteristics .....	5
2.2 Optical Characteristics .....	6
<b>3. Functional Block Diagram .....</b>	<b>9</b>
<b>4. Absolute Maximum Ratings .....</b>	<b>9</b>
4.1 Absolute Ratings of TFT-LCD Module .....	9
4.2 Absolute Ratings of Environment .....	9
<b>5. Electrical Characteristics .....</b>	<b>10</b>
5.1 TFT-LCD Driving .....	10
5.2 Backlight Unit .....	11
<b>6. Signal Characteristic .....</b>	<b>13</b>
6.1 Pixel Format Image .....	13
6.2 Scanning Direction .....	13
6.3 The Input Data Format .....	14
6.4 TFT-LCD Interface Signal Description .....	15
6.5 TFT-LCD Interface Timing .....	16
6.6 CCFL Backlight Unit Interface .....	18
6.7 Power ON/OFF Sequence .....	18
<b>7. Connector &amp; Pin Assignment .....</b>	<b>19</b>
7.1 TFT-LCD Signal (CN1): LCD Connector .....	19
7.2 Backlight Unit (CN2): Backlight Connector .....	19
7.3 PIN 1 Definition of CN1 and CN2 .....	20
<b>8. Reliability Test Criteria .....</b>	<b>21</b>
<b>9. Mechanical Characteristics .....</b>	<b>22</b>
<b>10. Label and Packaging .....</b>	<b>23</b>
10.1 Shipping Label (on the rear side of TFT-LCD display) .....	23
10.2 Carton Package .....	23
<b>11 Safety .....</b>	<b>24</b>
11.1 Sharp Edge Requirements .....	24
11.2 Materials .....	24
11.3 Capacitors .....	24
11.4 National Test Lab Requirement .....	24

## Record of Revision

Version and Date	Page	Old description	New Description	Remark																																																																										
0.1 Mar 19, 2007	All	First edition final specifications to all customers																																																																												
0.2 Jan 25, 2008	5	Support color: 16.2M or 262K	Support color:262K	Section 2																																																																										
	5	Typical Power Consumption 4.4W (IRCFL=5.0mA) 3.7W (IRCFL=3.8mA)	Typical Power Consumption 4.54W (IRCFL=5.0mA) 3.78W (IRCFL=3.8mA)	Section 2																																																																										
	5	No description	The most suitable view angle: 6 o'clock	Section 2.1																																																																										
	9	No description	Absolute Ratings of TFT-LCD Module CCFL Current: 6.5 mA (rms)	Section 4.1																																																																										
	11	<table border="1" style="width: 100%; border-collapse: collapse;"> <thead> <tr> <th>Symbol</th> <th>Min.</th> <th>Typ.</th> <th>Max.</th> <th>Unit</th> </tr> </thead> <tbody> <tr> <td>IRCFL</td> <td>3.5</td> <td>5</td> <td>7</td> <td>[mA] rms</td> </tr> <tr> <td>FCFL</td> <td>50</td> <td>60</td> <td>70</td> <td>[KHz]</td> </tr> <tr> <td>ViCFL (-10°C) (reference)</td> <td>-</td> <td>-</td> <td>1430</td> <td>[Volt] rms</td> </tr> <tr> <td rowspan="2">VCFL</td> <td>-</td> <td>365</td> <td>-</td> <td rowspan="2">[Volt] rms</td> </tr> <tr> <td>-</td> <td>386</td> <td>-</td> </tr> <tr> <td rowspan="2">PCFL</td> <td>-</td> <td>3.65</td> <td>-</td> <td rowspan="2">[Watt]</td> </tr> <tr> <td>-</td> <td>2.95</td> <td>-</td> </tr> </tbody> </table>		Symbol	Min.	Typ.	Max.	Unit	IRCFL	3.5	5	7	[mA] rms	FCFL	50	60	70	[KHz]	ViCFL (-10°C) (reference)	-	-	1430	[Volt] rms	VCFL	-	365	-	[Volt] rms	-	386	-	PCFL	-	3.65	-	[Watt]	-	2.95	-	<table border="1" style="width: 100%; border-collapse: collapse;"> <thead> <tr> <th>Symbol</th> <th>Min.</th> <th>Typ.</th> <th>Max.</th> <th>Unit</th> </tr> </thead> <tbody> <tr> <td>IRCFL</td> <td>2</td> <td>5</td> <td>6.5</td> <td>mA (rms)</td> </tr> <tr> <td>FCFL</td> <td>40</td> <td>50</td> <td>60</td> <td>KHz</td> </tr> <tr> <td>ViCFL (-20°C) (reference)</td> <td>-</td> <td>-</td> <td>1430</td> <td>V (rms)</td> </tr> <tr> <td rowspan="2">VCFL</td> <td>342</td> <td>380</td> <td>418</td> <td rowspan="2">Volt (rms)</td> </tr> <tr> <td>360</td> <td>400</td> <td>440</td> </tr> <tr> <td rowspan="2">PCFL</td> <td>-</td> <td>3.80</td> <td>-</td> <td rowspan="2">W</td> </tr> <tr> <td>-</td> <td>3.04</td> <td>-</td> </tr> </tbody> </table>		Symbol	Min.	Typ.	Max.	Unit	IRCFL	2	5	6.5	mA (rms)	FCFL	40	50	60	KHz	ViCFL (-20°C) (reference)	-	-	1430	V (rms)	VCFL	342	380	418	Volt (rms)	360	400	440	PCFL	-	3.80	-	W	-	3.04	-	Section 5.2.1
		Symbol	Min.	Typ.	Max.	Unit																																																																								
		IRCFL	3.5	5	7	[mA] rms																																																																								
		FCFL	50	60	70	[KHz]																																																																								
		ViCFL (-10°C) (reference)	-	-	1430	[Volt] rms																																																																								
		VCFL	-	365	-	[Volt] rms																																																																								
	-		386	-																																																																										
	PCFL	-	3.65	-	[Watt]																																																																									
		-	2.95	-																																																																										
	Symbol	Min.	Typ.	Max.	Unit																																																																									
	IRCFL	2	5	6.5	mA (rms)																																																																									
	FCFL	40	50	60	KHz																																																																									
	ViCFL (-20°C) (reference)	-	-	1430	V (rms)																																																																									
VCFL	342	380	418	Volt (rms)																																																																										
	360	400	440																																																																											
PCFL	-	3.80	-	W																																																																										
	-	3.04	-																																																																											
11,12			Revise Note 1, Note 4	Section 5.2.1																																																																										
16		No description	Add H/V mode timing characteristics	Section 6.5.1																																																																										
16		No description	Add Note 2, Note 3	Section 6.5.1																																																																										
17		No description	Add H/V mode input timing diagram	Section 6.5.2																																																																										
18		No description	Add CCFL Backlight Unit Interface	Section 6.6																																																																										
20			Revise PIN 1 definition of CN1 and CN2	Section 7.3																																																																										
21		Cold Start Test: -10°C	Cold Start Test: -20°C	Section 8																																																																										
21		No description	Add Note 2	Section 8																																																																										
22			Revise 2D drawing.	Section 9																																																																										
	<table border="1" style="width: 100%; border-collapse: collapse;"> <thead> <tr style="background-color: yellow;"> <th>Item</th> <th>Before</th> <th>After</th> <th>Remark</th> </tr> </thead> <tbody> <tr> <td>1</td> <td>29.5</td> <td>29.5±0.3</td> <td>Add tolerance</td> </tr> <tr> <td>2</td> <td>59</td> <td>59.0±0.3</td> <td>Add tolerance</td> </tr> <tr> <td>3</td> <td>31.0±0.3</td> <td>31.0±0.03</td> <td>Adjust tolerance</td> </tr> <tr> <td>4</td> <td>71.6</td> <td>(71.6)</td> <td>Change to reference value</td> </tr> <tr> <td>5</td> <td>33.2</td> <td>(33.2)</td> <td>Change to reference value</td> </tr> <tr> <td>6</td> <td>132.48</td> <td>132.48±0.3</td> <td>Add tolerance</td> </tr> <tr> <td>7</td> <td>99.36</td> <td>99.36±0.3</td> <td>Add tolerance</td> </tr> <tr> <td>8</td> <td>102.8±0.1</td> <td>102.8±0.3</td> <td>Adjust tolerance</td> </tr> <tr> <td>9</td> <td>135.9±0.5</td> <td>135.9±0.3</td> <td>Adjust tolerance</td> </tr> <tr> <td>10</td> <td>25.4</td> <td>25.4±0.3</td> <td>Add tolerance</td> </tr> <tr> <td>11</td> <td>7.1</td> <td>7.1±0.3</td> <td>Add tolerance</td> </tr> </tbody> </table>		Item		Before	After	Remark	1	29.5	29.5±0.3	Add tolerance	2	59	59.0±0.3	Add tolerance	3	31.0±0.3	31.0±0.03	Adjust tolerance	4	71.6	(71.6)	Change to reference value	5	33.2	(33.2)	Change to reference value	6	132.48	132.48±0.3	Add tolerance	7	99.36	99.36±0.3	Add tolerance	8	102.8±0.1	102.8±0.3	Adjust tolerance	9	135.9±0.5	135.9±0.3	Adjust tolerance	10	25.4	25.4±0.3	Add tolerance	11	7.1	7.1±0.3	Add tolerance																											
	Item	Before	After		Remark																																																																									
	1	29.5	29.5±0.3		Add tolerance																																																																									
	2	59	59.0±0.3		Add tolerance																																																																									
	3	31.0±0.3	31.0±0.03		Adjust tolerance																																																																									
	4	71.6	(71.6)		Change to reference value																																																																									
	5	33.2	(33.2)		Change to reference value																																																																									
	6	132.48	132.48±0.3		Add tolerance																																																																									
	7	99.36	99.36±0.3		Add tolerance																																																																									
	8	102.8±0.1	102.8±0.3		Adjust tolerance																																																																									
	9	135.9±0.5	135.9±0.3		Adjust tolerance																																																																									
10	25.4	25.4±0.3	Add tolerance																																																																											
11	7.1	7.1±0.3	Add tolerance																																																																											

## 1. Operating Precautions

- 1) Display area (Polarizer) of TFT-LCD Module is easily to be damaged, please be cautious and not to scratch it.
- 2) Be sure to power off your machine before connecting or disconnecting your signal cable to TFT-LCD Module.
- 3) Wipe off water drop on display area immediately. Long contact with water may cause discoloration or spots.
- 4) When the panel surface is soiled, wipe it with absorbent cotton or soft cloth.
- 5) Display area (Glass) of TFT-LCD Module may be broken or cracked if bump Module against hard object.
- 6) To avoid ESD (Electro Static Discharge) damage, be sure to ground yourself before handling TFT-LCD Module.
- 7) Do not open nor modify the TFT-LCD Module assembly.
- 8) Do not press the reflector sheet at the back of the module to any direction.
- 9) In case if a TFT-LCD Module has to be put back into the packing container slot after it was taken out from the container, do not press the center of the CCFL Reflector edge. Instead, press at the far ends of the CCFL Reflector edge softly. Otherwise the TFT-LCD Module may be damaged.
- 10) When inserting or removing of your signal cable to TFT-LCD Module, be sure not to apply abnormal force (rotate, tilt...etc.) to the Connector of the TFT-LCD Module.
- 11) TFT-LCD Module is not allowed to be twisted & bent even force is added on module in a very short time. Please design your display product well to avoid external force applying to module by end-user directly.
- 12) Cold cathode fluorescent lamp (CCFL) in TFT-LCD Module contains a small amount of mercury. Please follow local ordinances or regulations for disposal.
- 13) Small amount of materials having no flammability grade is used in the TFT-LCD Module. The TFT-LCD Module should be supplied by power complied with requirements of Limited Power Source (IEC60950 or UL1950), or be applied exemption.
- 14) The CCFL in TFT-LCD Module should be supplied by inverter complied with Limited Current Circuit (IEC60950 or UL1950). Do not connect the CCFL with Hazardous Voltage Circuit.
- 15) Severe temperature condition may result in different luminance, response time and lamp ignition voltage.
- 16) Continuous operating TFT-LCD Module under low temperature environment may accelerate lamp exhaustion and reduce luminance dramatically.
- 17) The data on this specification sheet is applicable when TFT-LCD Module is placed in landscape position.
- 18) Continuous displaying fixed pattern may induce image sticking. It's recommended to use screen saver or moving content periodically if fixed pattern is displayed on the screen.

## 2. General Description

G065VN01 V1 is designed for industrial display applications with VGA (640 x RGB x 480) resolution and 262k colors (RGB 6-bits). It is composed of a TFT-LCD panel, driver ICs, control and power supply circuits and a backlight unit. G065VN01 V1 offers CMOS interface for display signal input. Inverter board of backlight is not included.

### 2.1 Display Characteristics

The following items are G065VN01 V1 characteristics summary at 25 °C condition.

Items	Unit	Specifications
Screen Diagonal	inch	6.5
Active Area	mm	132.48(H) x 99.36(V)
Pixels H x V		640x3(RGB) x 480
Pixel Pitch	mm	0.207 x 0.207
Pixel Arrangement		R.G.B. Vertical Stripe
Display Mode		TN, Normally White
Nominal Input Voltage VDD	V	3.3 typ.
Typical Power Consumption	W	4.54W (IRCFL=5.0mA) 3.78W (IRCFL=3.8mA) All black pattern
Weight	Grams	200g(typ.)
Physical Size	mm	153.0(H)x 118.0(V) x 10.7(D) (typ.)
Electrical Interface		CMOS 6-bit Parallel RGB
Surface Treatment		Anti-glare, Hardness 3H
Support Color		262K colors
The most suitable view angle		6 o'clock
Temperature Range Operating Storage (Non-Operating)	°C °C	-20 to +70 -20 to +80
RoHS Compliance		RoHS Compliance

## 2.2 Optical Characteristics

The optical characteristics are measured under stable conditions at 25°C (Room Temperature).

Item	Unit	Conditions	Min.	Typ.	Max.	Note
White Luminance	cd/m <sup>2</sup>	IRCFL= 5.0mA (center point)	400	500	-	1
		IRCFL= 3.8mA (center point)	320	400	-	
Uniformity	%	5 Points	-	-	1.25	1, 2, 3, 4
		13 Points	-	-	1.67	
Contrast Ratio			300	600	-	5
Response Time	msec	Rising	-	15	20	6
	msec	Falling	-	10	15	
	msec	Raising + Falling	-	25	35	
Viewing Angle	degree degree	Horizontal (Right) CR = 10 (Left)	60	70	-	7
			60	70	-	
	degree degree	Vertical (Upper) CR = 10 (Lower)	50	60	-	
			50	60	-	
Color / Chromaticity Coordinates (CIE 1931)		Red x	0.590	0.620	0.650	
		Red y	0.320	0.350	0.380	
		Green x	0.275	0.305	0.335	
		Green y	0.550	0.580	0.610	
		Blue x	0.115	0.145	0.175	
		Blue y	0.085	0.115	0.145	
		White x	0.283	0.313	0.343	
		White y	0.299	0.329	0.359	
Color Gamut	%		50	55	-	

### Note 1: Measurement method

- Equipment      Pattern Generator, Power Supply, Digital Voltmeter, Luminance meter (SR\_3 or equivalent)
- Aperture        1° with 50cm viewing distance
- Test Point      Center
- Environment    < 1 lux

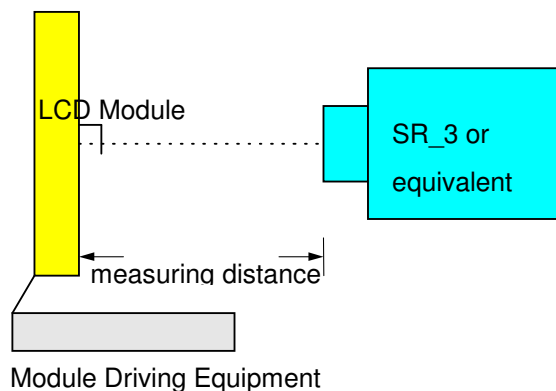

Note 2: Definition of 5 points position (Display active area: 132.48mm(W) x 99.36mm(H))

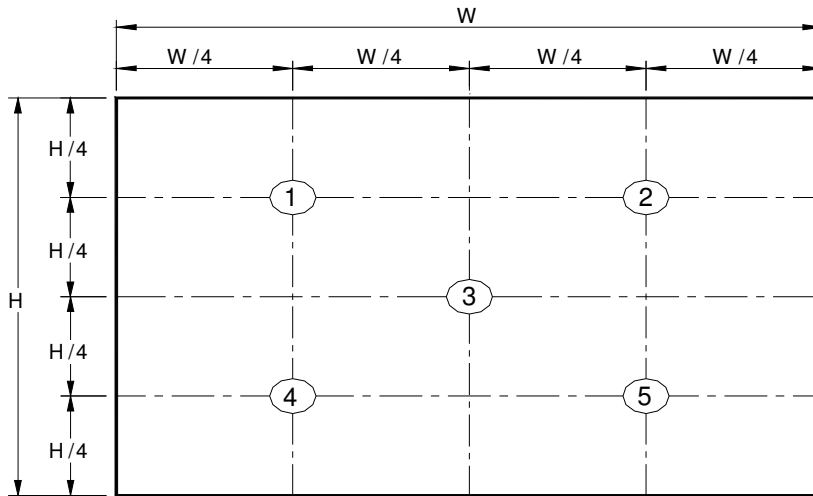

Note 3: Definition of 13 points position

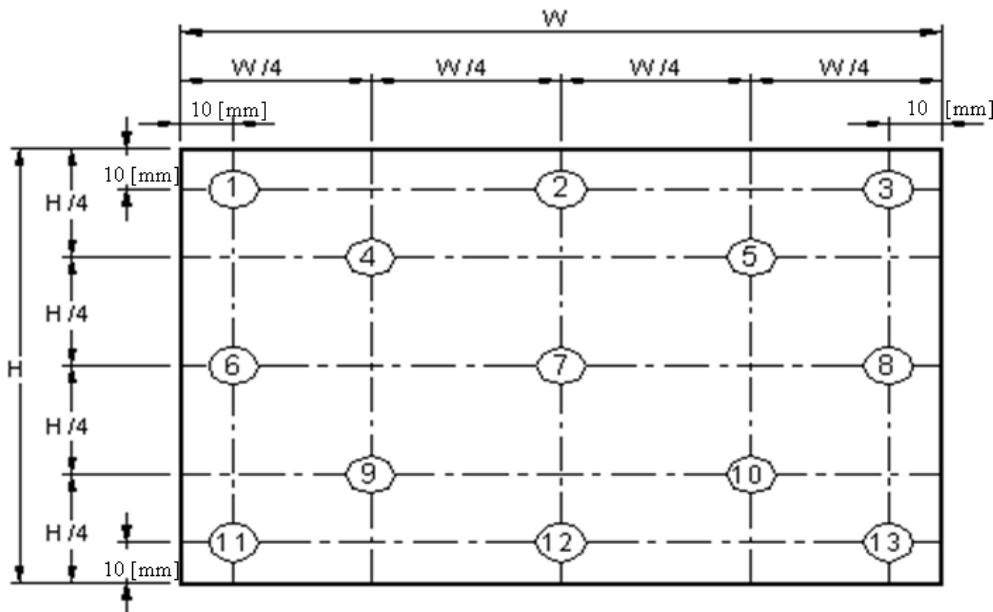

Note 4:

The luminance uniformity of 5 and 13 points is defined by dividing the maximum luminance value by the minimum luminance value at full white condition.

$$\delta_{W5} = \frac{\text{Maximum Brightness of five points}}{\text{Minimum Brightness of five points}}$$

$$\delta_{W13} = \frac{\text{Maximum Brightness of thirteen points}}{\text{Minimum Brightness of thirteen points}}$$

Note 5: Definition of contrast ratio (CR):

$$\text{Contrast ratio (CR)} = \frac{\text{Brightness on the "White" state}}{\text{Brightness on the "Black" state}}$$

Note 6: Definition of response time:

The output signals of photo detector are measured when the input signals are changed from "White" to "Black" (falling time) and from "Black" to "White" (rising time), respectively. The response time interval definition is between 10% and 90% of amplitude. Please refer to the figure as below.

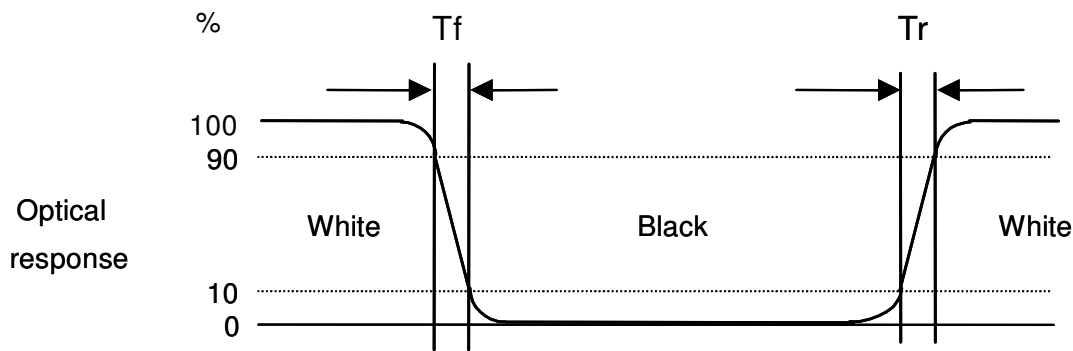

Note 7: Definition of viewing angle

Viewing angle is the measurement of contrast ratio  $\geq 10$ , at the screen center, over 180° horizontal and 180° vertical range. The 180° horizontal ( $\theta_L, \theta_R$ ) and 180° vertical ( $\phi_H, \phi_L$ ) range are illustrated as following figure.

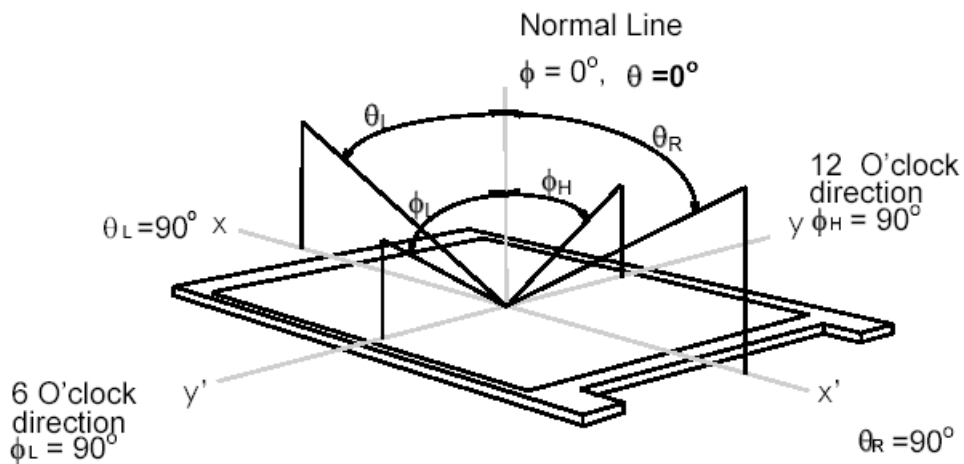



### 3. Functional Block Diagram

The following diagram shows the functional block of the G065VN01 V1 color TFT-LCD module.

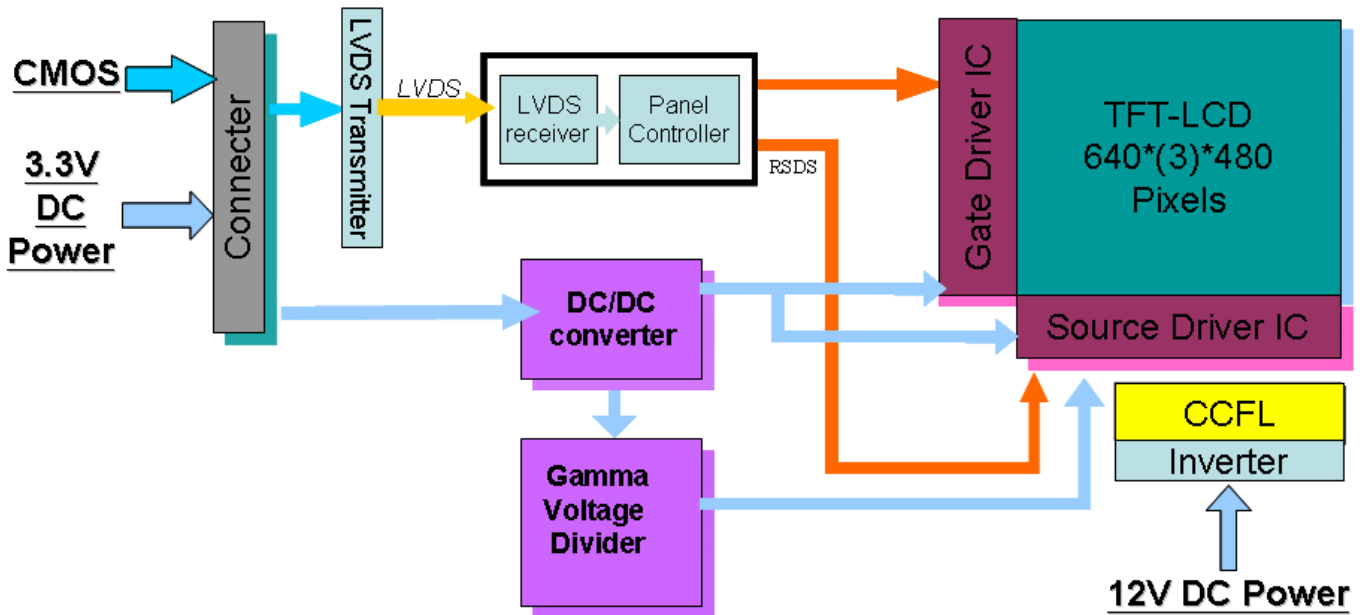

### 4. Absolute Maximum Ratings

#### 4.1 Absolute Ratings of TFT-LCD Module

Item	Symbol	Min	Max	Unit
Logic/LCD Drive Voltage	VDD	-0.3	+4.0	V
CCFL Current	IRCFL	-	6.5	mA (rms)

#### 4.2 Absolute Ratings of Environment

Item	Symbol	Min	Max	Unit
Operating Temperature	TOP	-20	+70	°C
Operation Humidity	HOP	5	95	%RH
Storage Temperature	TST	-20	+80	°C
Storage Humidity	HST	5	95	%RH

Note 1: Maximum Wet-Bulb should be 39°C and no condensation.

## 5. Electrical Characteristics

### 5.1 TFT-LCD Driving

#### 5.1.1 Power Specification

Symbol	Parameter	Min	Typ	Max	Units	Remark
VDD	Logic/LCD Drive Voltage	3.0	3.3	3.6	V	
IDD	VDD Current	-	225	-	mA	All Black Pattern (VDD=3.3V, at 60Hz)
Irush	LCD Inrush Current	-	-	1.5	A	Note 1
PDD	VDD Power	-	0.74	-	W	All Black Pattern (VDD=3.3V, at 60Hz)
VDDrp	Allowable Logic/LCD Drive Ripple Voltage	-	-	100	mVp-p	All Black Pattern (VDD=3.3V, at 60Hz)

Note 1: Measurement condition:

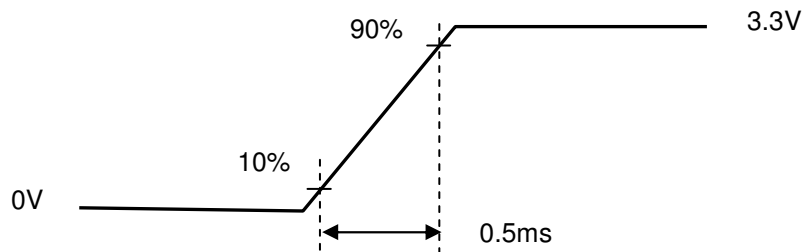
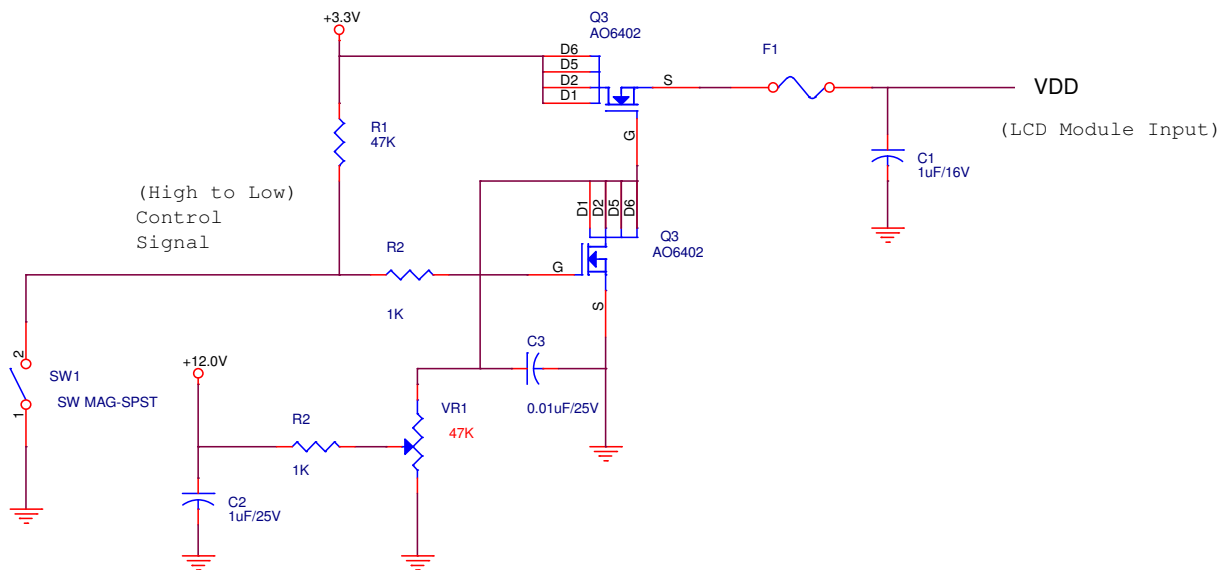

VDD rising time

### 5.1.2 Signal Electrical Characteristics

Input signals shall be low or Hi-Z state when VDD is off.

Parameter		Symbol	Min.	Typ.	Max.	Unit	Remarks
Logic Input Voltage for Display Signals	High	VIH	0.7VDD	-	VDD	V	
	Low	VIL	0	-	0.3VDD	V	
Input Voltage for DPS	High	VIH	0.7VDD	-	VDD	V	
	Low	VIL	0	-	0.3VDD	V	

## 5.2 Backlight Unit

### 5.2.1 Parameter guideline for CCFL

Following characteristics are measured under a stable condition using an inverter at 25°C (Room Temperature).

Symbol	Parameter	Min.	Typ.	Max.	Unit	Remark
IRCFL	CCFL Operation Current	2	5	6.5	mA (rms)	(Ta=25°C) Note 1, 5
FCFL	CCFL Operation Frequency	40	50	60	KHz	(Ta=25°C) Note 2
ViCFL (-20°C) (reference)	CCFL Ignition Voltage	-	-	1430	V (rms)	(Ta= -20°C)
ViCFL (25°C) (reference)	CCFL Ignition Voltage	-	-	650	Volt (rms)	(Ta=25°C)
VCFL	CCFL Operation Voltage	342	380	418	Volt (rms)	(Ta=25°C) IRCFL=5mA
		360	400	440		(Ta=25°C) IRCFL=3.8mA
PCFL	CCFL Power Consumption (inverter excluded)	-	3.80	-	W	(Ta=25°C) Note 3 IRCFL=5mA
		-	3.04	-		(Ta=25°C) Note 3 IRCFL=3.8mA
Lamp Life		50,000			Hrs	(Ta=25°C) Note 4 IRCFL= 5mA

Note 1: IRCFL is defined as the return current of an inverter. (In Figure. 1)

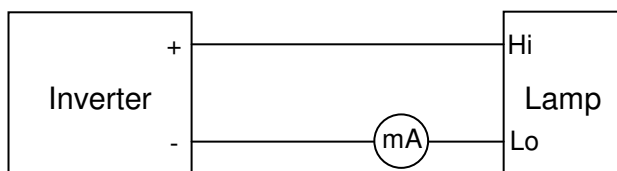

(Figure. 1: Measurement of return current)

A stable IRCFL is a current without flicker or biasing waveform provided by inverter that ensures the backlight perform to its specification. The ideal sine waveform should be symmetric in positive and negative polarities and the asymmetry rate of the inverter waveform should be below 10%.

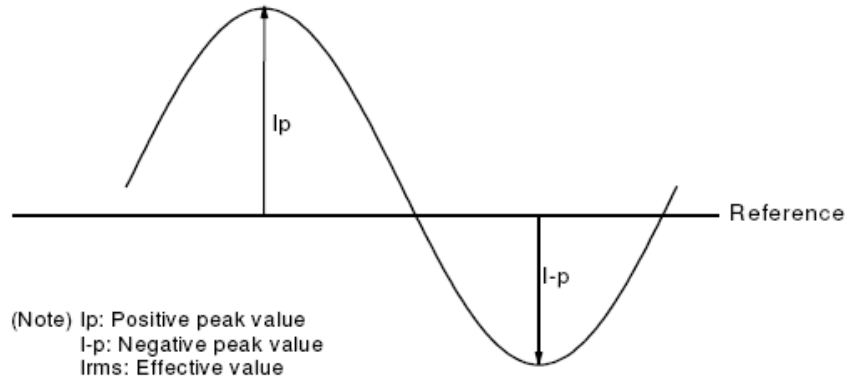

$$\text{DC Bias} = (|I_p - I-p| / I_{rms}) \times 100 \% < 10\%$$

$$\text{Crest Factor} = I_p \text{ or } (I-p) / I_{rms} \text{ should have the range within } 1.414 \pm 10\%$$

It is recommended to use the inverter with detection circuit (ie: balance and protection circuit) to avoid over voltage, over current, or mismatching waveform.

Note 2: CCFL operation frequency should be carefully determined to avoid interference between inverter and TFT-LCD. Higher frequency will induce higher leakage current and further impact lamp life.

Note 3: Calculation value for reference ( $IRCFL \times VCFL \times 2 = PCFL$ ).

Note 4: The definition of lamp life means when any of following conditions happen:

- a) Luminance falls to 50% or less of the initial value.
- b) Normal lighting is no more available (flickering, pink lighting, no lighting, etc.)
- c) Lamp operation voltage or ignition voltage exceeds the specified value.

Lamp life time shortens according to,

- ◆ Placing methodology: mercury is unevenly distributed in portrait mounting.
- ◆ Environmental condition: mercury vapor quantity contained in lamp is reduced at low temperature condition, which results in approximately 1,000 hours lamp life.
- ◆ CCFL surface temperature: Temperature gradient on lamp surface causes uneven mercury migration.
- ◆ Inverter design: its resonance capacitor should be fine-tuned according to the impedance of CCFL.
- ◆ Over driving current ( $> 5.5 \text{ mA}$ ) shortens lamp life time dramatically.

Note 5: The display is with dual lamp design, and the CCFL operation current in above table is for each lamp.

## 6. Signal Characteristic

### 6.1 Pixel Format Image

Following figure shows the relationship between input signal and LCD pixel format.

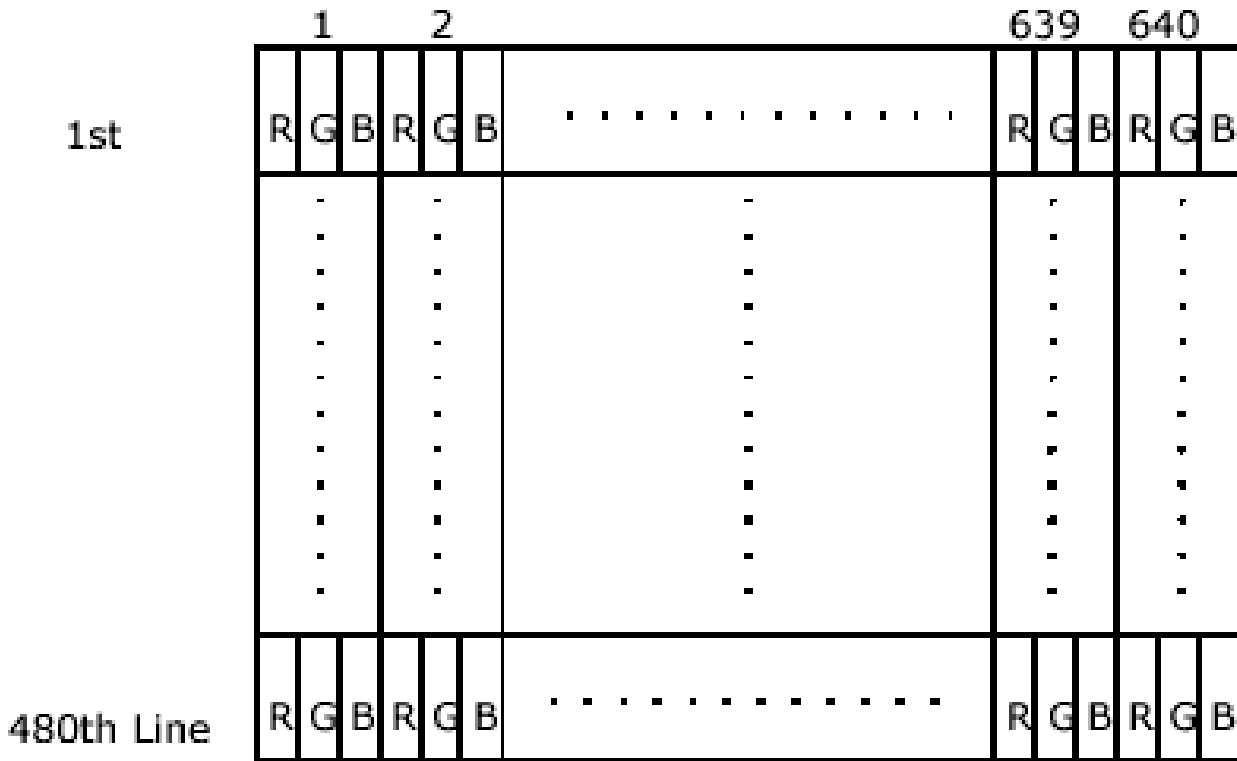

### 6.2 Scanning Direction

The following figures show the image seen from the front view. The arrow indicates the direction of scan.

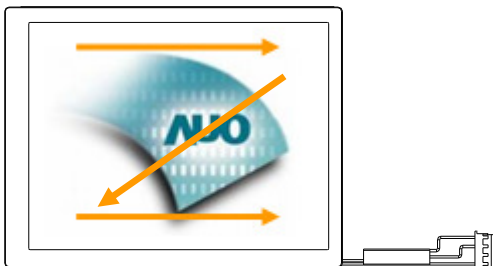

Fig. 1 Normal scan (Pin31, DPS = Low or NC)



Fig. 2 Reverse scan (Pin31, DPS = High)

Note 1: TFT-LCD interface signal description is shown in section 6.4.

### 6.3 The Input Data Format

This product displays 262,144 colors in terms of the 64 grey levels on RGB respectively. The following table demonstrates the display of input data.

Display colors		Data signal (0: Low level, 1: High level)																	
		R5	R4	R3	R2	R1	R0	G5	G4	G3	G2	G1	G0	B5	B4	B3	B2	B1	B0
Basic colors	Black	0	0	0	0	0	0	0	0	0	0	0	0	0	0	0	0	0	0
	Blue	0	0	0	0	0	0	0	0	0	0	0	0	1	1	1	1	1	1
	Red	1	1	1	1	1	1	0	0	0	0	0	0	0	0	0	0	0	0
	Magenta	1	1	1	1	1	1	0	0	0	0	0	0	1	1	1	1	1	1
	Green	0	0	0	0	0	0	1	1	1	1	1	1	0	0	0	0	0	0
	Cyan	0	0	0	0	0	0	1	1	1	1	1	1	1	1	1	1	1	1
	Yellow	1	1	1	1	1	1	1	1	1	1	1	1	0	0	0	0	0	0
	White	1	1	1	1	1	1	1	1	1	1	1	1	1	1	1	1	1	1
Red gray scale	Black	0	0	0	0	0	0	0	0	0	0	0	0	0	0	0	0	0	0
		0	0	0	0	0	1	0	0	0	0	0	0	0	0	0	0	0	0
	dark	0	0	0	0	1	0	0	0	0	0	0	0	0	0	0	0	0	0
	↑				⋮														
	↓				⋮														
	bright	1	1	1	1	0	1	0	0	0	0	0	0	0	0	0	0	0	0
Red	1	1	1	1	1	0	0	0	0	0	0	0	0	0	0	0	0	0	
Red	1	1	1	1	1	1	0	0	0	0	0	0	0	0	0	0	0	0	
Green gray scale	Black	0	0	0	0	0	0	0	0	0	0	0	0	0	0	0	0	0	0
		0	0	0	0	0	0	0	0	0	0	1	0	0	0	0	0	0	0
	dark	0	0	0	0	0	0	0	0	0	0	1	0	0	0	0	0	0	0
	↑				⋮														
	↓				⋮														
	bright	0	0	0	0	0	0	1	1	1	1	0	1	0	0	0	0	0	0
Green	0	0	0	0	0	0	1	1	1	1	1	0	0	0	0	0	0	0	
Green	0	0	0	0	0	0	1	1	1	1	1	1	0	0	0	0	0	0	
Blue gray scale	Black	0	0	0	0	0	0	0	0	0	0	0	0	0	0	0	0	0	0
		0	0	0	0	0	0	0	0	0	0	0	0	0	0	0	0	0	1
	dark	0	0	0	0	0	0	0	0	0	0	0	0	0	0	0	0	1	0
	↑				⋮														
	↓				⋮														
	bright	0	0	0	0	0	0	0	0	0	0	0	0	1	1	1	1	0	1
Blue	0	0	0	0	0	0	0	0	0	0	0	0	1	1	1	1	1	0	
Blue	0	0	0	0	0	0	0	0	0	0	0	0	1	1	1	1	1	1	

## 6.4 TFT-LCD Interface Signal Description

PIN No.	Symbol	Pin Description
1	GND	Ground
2	DOTCLK	Dot clock
3	Hsync	Horizontal synchronous signal
4	Vsync	Vertical synchronous signal
5	GND	Ground
6	R0	Red data (LSB)
7	R1	Red data
8	R2	Red data
9	R3	Red data
10	R4	Red data
11	R5	Red data (MSB)
12	GND	Ground
13	G0	Green data (LSB)
14	G1	Green data
15	G2	Green data
16	G3	Green data
17	G4	Green data
18	G5	Green data (MSB)
19	GND	Ground
20	B0	Blue data (LSB)
21	B1	Blue data
22	B2	Blue data
23	B3	Blue data
24	B4	Blue data
25	B5	Blue data (MSB)
26	GND	Ground
27	DE	Data Enable Signal
28	VDD	Power supply (3.3V Typ. ONLY)
29	VDD	Power supply (3.3V Typ. ONLY)
30	Reserved	No Connection or "Low" (For AUO internal test)
31	DPS	No Connection or "Low": Normal Display (Default) High: Reversed Display (180° Rotation)

Note 1: Input signals shall be in low status when VDD is off.

## 6.5 TFT-LCD Interface Timing

### 6.5.1 Timing Characteristics

#### DE mode

Signal	Parameter	Symbol	Min.	Typ.	Max.	Unit	Remark	
Clock Timing	Clock frequency (DOTCLK)	$1/T_{\text{CLOCK}}$	20	25.2	50	MHz	Note1, 2	
Hsync Timing	Horizontal Section	Period	$T_H$	770	800	1070	$T_{\text{CLOCK}}$	Note1, 2
		Active	$T_{\text{HD}}$	640	640	640		
		Blanking	$T_{\text{HB}}$	130	160	430		
Vsync Timing	Vertical Section	Period	$T_V$	520	525	622	$T_{\text{LINE}}$	Note1, 2
		Active	$T_{\text{VD}}$	480	480	480		
		Blanking	$T_{\text{VB}}$	40	45	142		

#### H/V mode

Signal	Parameter	Symbol	Min.	Typ.	Max.	Unit	Remark	
Clock Timing	Clock frequency (DOTCLK)	$1/T_{\text{CLOCK}}$	20	25.2	50	MHz	Note 3	
Hsync Timing	Horizontal Section	Display period	$T_{\text{HSD}}$	640			$T_{\text{CLOCK}}$	Note 3
		Front porch	$T_{\text{HSF}}$	30	60	330		
		Hsync pulse width + Back porch	$T_{\text{HSW}}+T_{\text{HSB}}$	100				
		Hsync Period	$T_{\text{HS}}$	770	800	1070		
Vsync Timing	Vertical Section	Display period	$T_{\text{VSD}}$	480			$T_{\text{LINE}}$	Note 3
		Front porch	$T_{\text{VSF}}$	5	10	107		
		Vsync pulse width + Back porch	$T_{\text{VSW}}+T_{\text{VSB}}$	35				
		Vsync Period	$T_{\text{VS}}$	520	525	622		

Note 1: Recommended frame rate is 60 Hz.

Note 2: G065VN01 V1 TFT-LCD Module can support DE & H/V mode. When DE and H/V signal are existed simultaneously, G065VN01 V1 TFT-LCD Module is operated in DE mode only.

Note 3: H/V mode is negative polarity.



6.5.2 DE & H/V Mode Input Timing Diagram

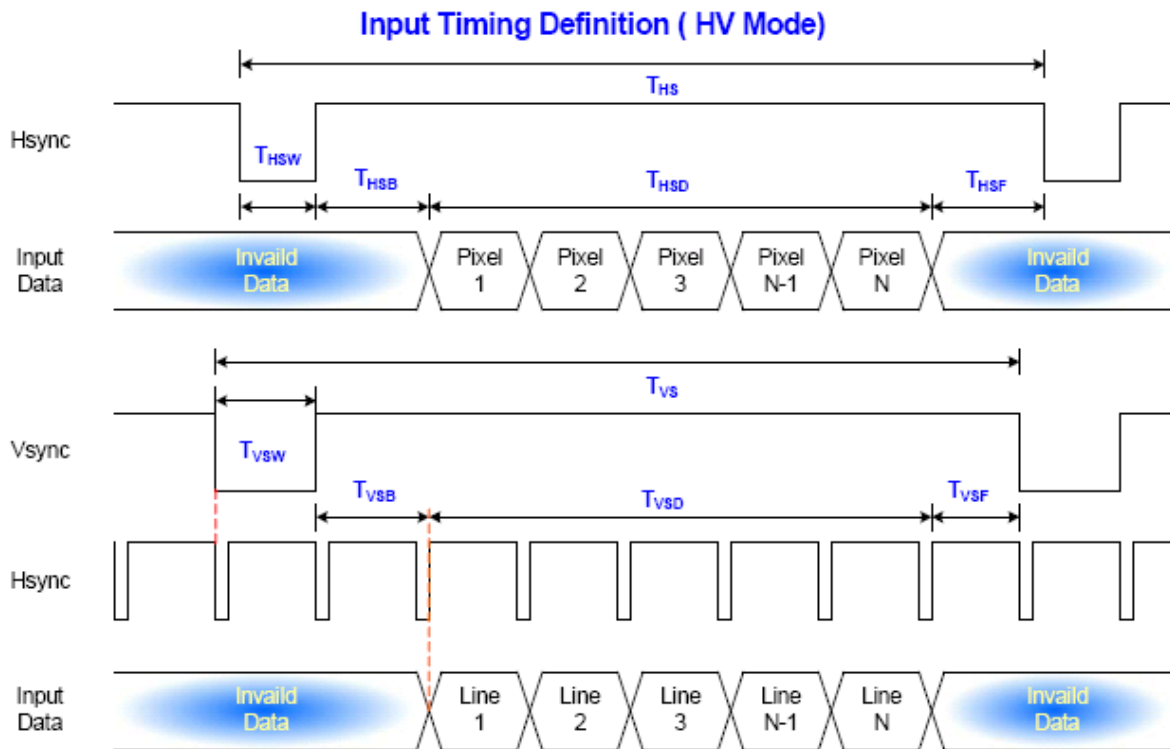
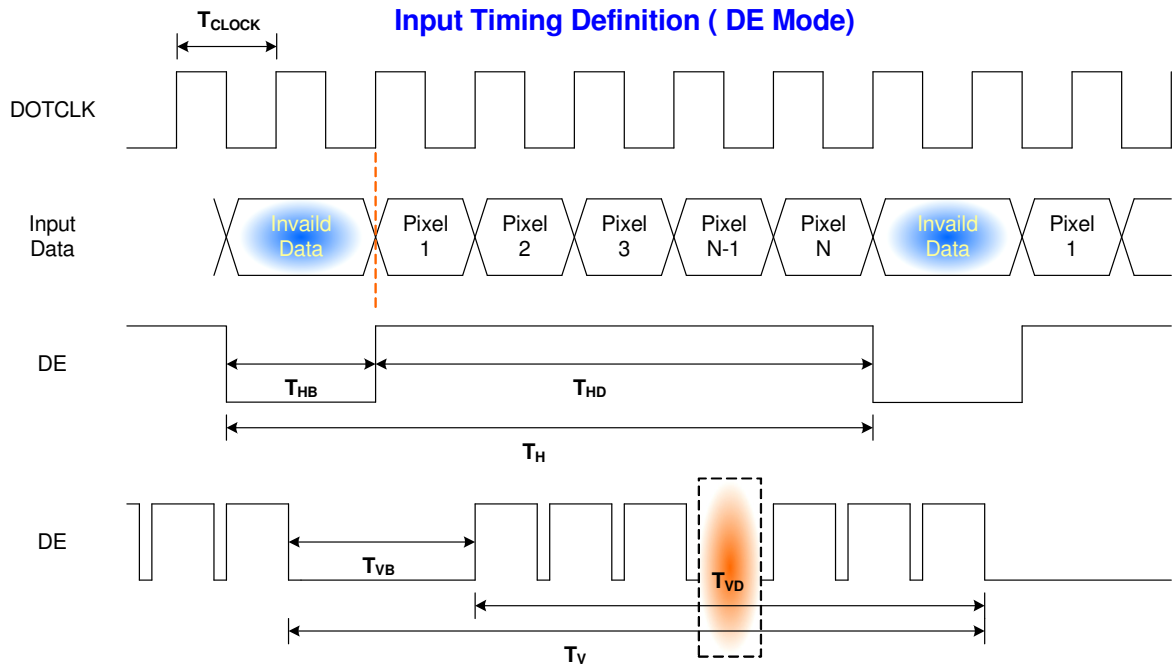

## 6.6 CCFL Backlight Unit Interface

Pin No.	Cable color	Symbol	Pin Description
1	Pink	Hot1	Lamp High Voltage
2	Pink	Hot2	Lamp High Voltage
3		NC	No Connection
4	White	Cold1	Lamp Low Voltage

## 6.7 Power ON/OFF Sequence

VDD power, LCD interface signals and backlight on/off sequence are shown in the following chart. Signals from any system shall be Hi-Z state or low level when VDD is off.

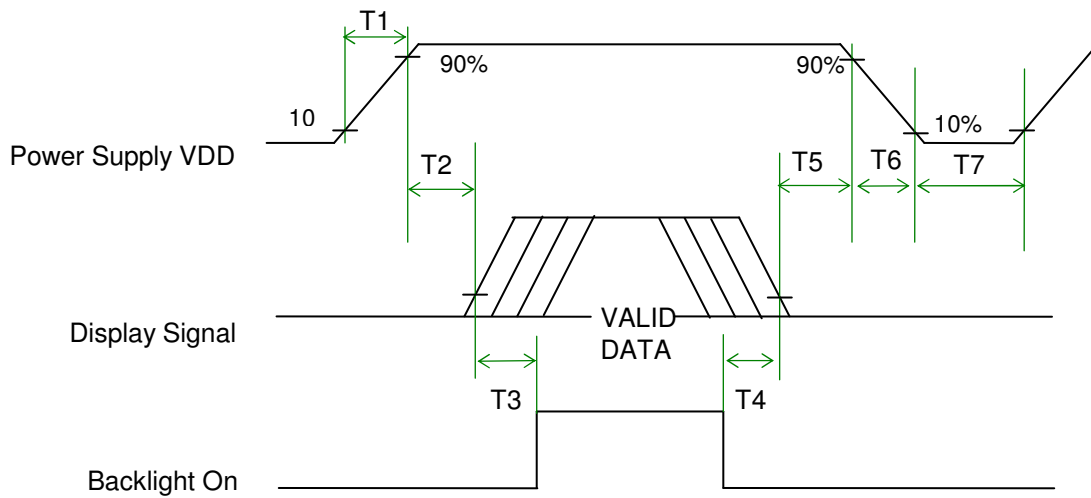

### Power ON/OFF sequence timing

Parameter	Value			Units
	Min.	Typ.	Max.	
T1	0.5	-	10	ms
T2	0	-	50	ms
T3	180	-	-	ms
T4	180	-	-	ms
T5	0	-	50	ms
T6	0	-	10	ms
T7	500	-	-	ms

ON/OFF sequence should be applied to avoid abnormal function in the display. Please make sure to turn off the power when you plug the cable into the input connector or pull the cable out of the connector.

## 7. Connector & Pin Assignment

### 7.1 TFT-LCD Signal (CN1): LCD Connector

Connector Name / Designation	Signal Connector
Manufacturer	Hirose or compatible
Connector Model Number	DF9B-31P-1V or compatible
Mating Connector Model Number	DF9B-31S-1V or compatible

Pin#	Symbol	Pin#	Symbol	Pin#	Symbol
1	GND	12	GND	23	B3
2	CLK	13	G0	24	B4
3	Hsync	14	G1	25	B5
4	Vsync	15	G2	26	GND
5	GND	16	G3	27	DE
6	R0	17	G4	28	VDD
7	R1	18	G5	29	VDD
8	R2	19	GND	30	Reserved
9	R3	20	B0	31	DPS
10	R4	21	B1		
11	R5	22	B2		

### 7.2 Backlight Unit (CN2): Backlight Connector

Connector Name / Designation	Lamp Connector
Manufacturer	JST or compatible
Connector Model Number	BHR-04VS-1 or compatible
Mating Connector Model Number	SM04(4.0)B-BHS-1-TB or compatible

Pin No.	Symbol
1	Hot1
2	Hot2
3	NC
4	Cold1

### 7.3 PIN 1 Definition of CN1 and CN2

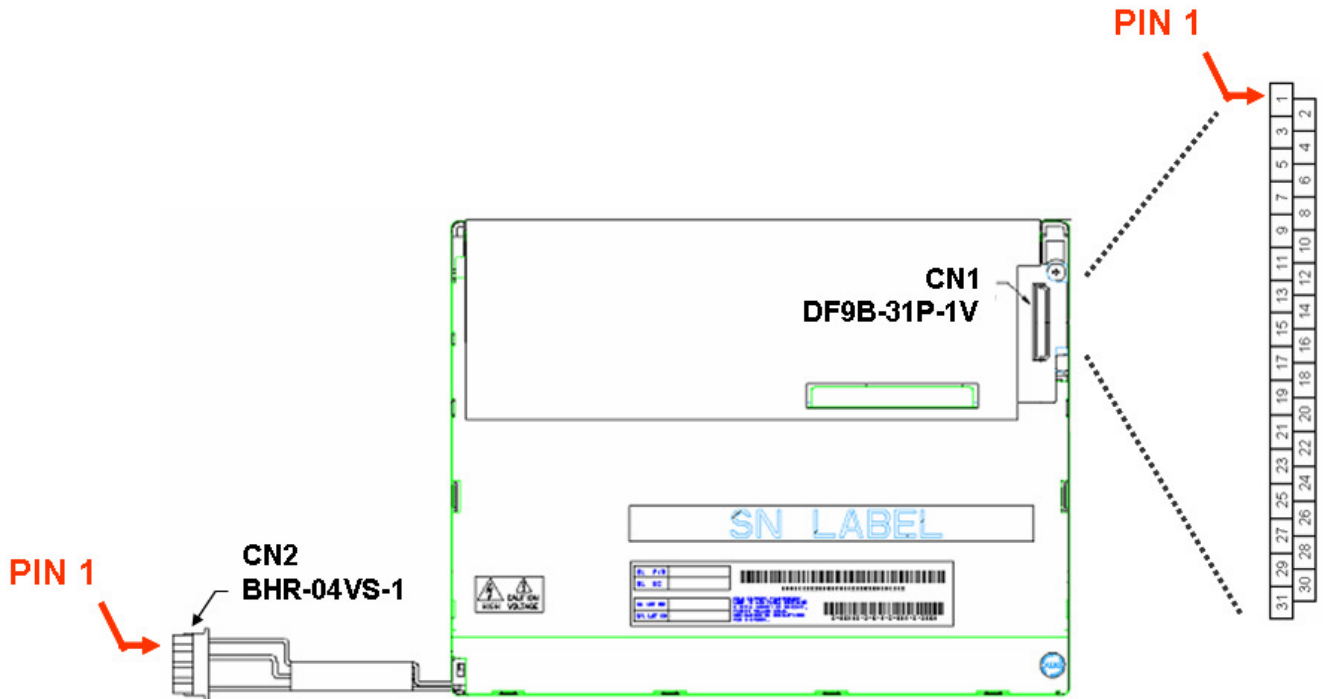

Rear side of TFT-LCD module

## 8. Reliability Test Criteria

Items	Required Condition	Note
Temperature Humidity Bias	40°C /90%,300Hr	Note 2
High Temperature Operation	70°C ,300Hr	Note 2
Low Temperature Operation	-20°C ,300Hr	Note 2
High Temperature Storage	80°C ,300 hours	Note 2
Low Temperature Storage	-20°C ,300 hours	Note 2
Thermal Shock Test	-20°C/30 min ,60°C/30 min ,100cycles	Note 2
Hot Start Test	70°C/1 Hr (min.), power on/off per 5 minutes, repeat 5 times	Note 2
Cold Start Test	-20°C/1 Hr (min.), power on/off per 5 minutes, repeat 5 times	Note 2
Shock Test (Non-Operating)	50G,11ms,Half-sine wave,(±X, ±Y, ±Z)	Note 2
Vibration Test (Non-Operating)	1.5G, 50~500~50Hz, Sine wave, 30mins/axis, 3 direction (X, Y, Z)	Note 2
ESD	Contact Discharge: ±8KV, 150pF(330Ω) 1sec, 8 points, 25 times/point Air Discharge: ±15KV, 150pF(330Ω) 1sec, 8 points, 25 times/point	Note 1,2
Attitude Test	Operating: 14,000 ft, Ramp: 2000 ft/min, 8hrs Non-operating: 40,000 ft, Ramp: 2000 ft/min, 24hrs	Note 2

Note1: According to EN61000-4-2 ESD class B criteria, some performance degradation is allowed. TFT-LCD module is self-recoverable, no data lost and no hardware failures after test.

Note2:

- Water condensation is not allowed for each test items.
- Each test is done by new TFT-LCD module. Please don't use the same TFT-LCD module repeatedly for reliability test.
- The reliability test is performed only to examine the TFT-LCD module.
- To inspect TFT-LCD module after reliability test, please store it at room temperature and room humidity for 24 hour at least in advance.

# 9. Mechanical Characteristics

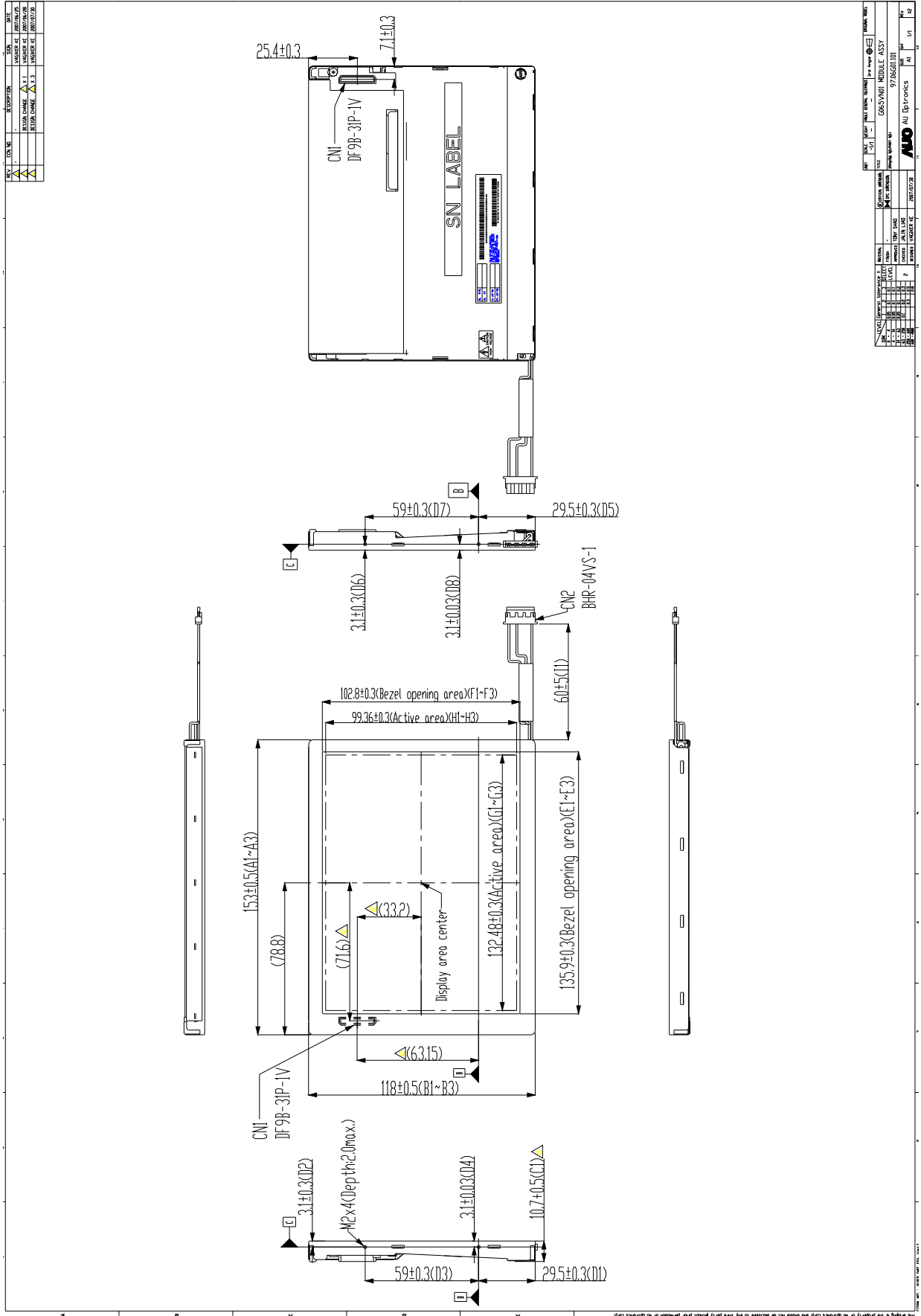

Note 1: Self-tapping Screw suggested torque value: Maximum 2.0 kgf-cm



## **11 Safety**

### **11.1 Sharp Edge Requirements**

There will be no sharp edges or comers on the display assembly that could cause injury.

### **11.2 Materials**

#### **11.2.1 Toxicity**

There will be no carcinogenic materials used anywhere in the TFT-LCD module. If toxic materials are used, they will be reviewed and approved by the responsible AUO toxicologist.

#### **11.2.2 Flammability**

All components including electrical components that do not meet the flammability grade UL94-V1 in the TFT-LCD Module will complete the flammability rating exception approval process.

The printed circuit board will be made from material rated 94-V1 or better. The actual UL flammability rating will be printed on the printed circuit board.

### **11.3 Capacitors**

If any polarized capacitors are used in the TFT-LCD module, provisions will be made to keep them from being inserted backwards.

### **11.4 National Test Lab Requirement**

The TFT-LCD Module will satisfy all requirements for compliance to UL 60950 (U.S.A. Information Technology equipment).