

LCD Module Specification

First Edition

June 18, 1998

Final Revision

Approved by Production Div.

Checked by Quality Assurance Div.

Checked by Design Engineering Div.

Type No. **DMF-50036ZNFU-FW**

Prepared by Production Div.

Table of Contents

1. General Specifications.....	2
2. Electrical Specifications.....	3
3. Optical Specifications.....	8
4. I/O Terminal.....	10
5. Test.....	12
6. Appearance Standards.....	13
7. Code System of Production Lot.....	16
8. Type Number.....	16
9. Applying Precautions.....	16
10. Handling Precautions.....	17

Revision History

Rev.	Date	Page	Comment



1.General Specifications

Operating Temp.	:	min. 10°C ~ max. 40°C
Storage Temp.	:	min. -20°C ~ max. 60°C
Dot Pixels	:	640 (W) × 200 (H) dots
Dot Size	:	0.32 (W) × 0.46 (H) mm
Dot Pitch	:	0.35 (W) × 0.49 (H) mm
Viewing Area	:	231.0 (W) × 105.0 (H) mm
Outline Dimensions	:	270.0 (W) × (142.0)* (H) × 13.5 max. (D) mm * Without CFL Cable
Weight	:	600 g max.
LCD Type	:	NTD-10713 (F-STN / Black & White -mode / Transmissive)
Viewing Angle	:	12:00
Data Transfer	:	4-bit parallel data transfer
Backlight	:	Cold Cathode Fluorescent Lamp (CFL) × 1
Drawings	:	Dimensional Outline UE-20575B

2. Electrical Specifications

2.1. Absolute Maximum Ratings

V_{SS}=0V

Parameter	Symbol	Conditions	Min.	Max.	Units
Supply Voltage (Logic)	V _{CC} -V _{SS}	–	-0.3	7.0	V
Supply Voltage (LCD Drive)	V _{CC} -V _{EE}	–	0	32.0	V
Input Voltage	V _I	–	-0.3	V _{CC} +0.3	V

2.2. DC Characteristics

T_a=25°C, V_{SS}=0V

Parameter	Symbol	Conditions	Min.	Typ.	Max.	Units
Supply Voltage (Logic)	V _{CC} -V _{SS}	–	4.5	–	5.5	V
Supply Voltage (LCD Drive)	V _{CC} -V _{EE}	–	27.0	–	30.0	V
	V _{CC} -V _{ADJ}	Shown in 3.1				V
High Level Input Voltage	V _{IH}	V _{CC} =5.0V±10%	0.8×V _{CC}	–	V _{CC}	V
Low Level Input Voltage	V _{IL}	V _{CC} =5.0V±10%	0	–	0.2×V _{CC}	V
Supply Current	I _{CC}	V _{CC} -V _{SS} =5.0V	–	8.0	30.0	mA
	I _{EE}	V _{CC} -V _{ADJ} = V	–	7.0	25.0	mA
Clock Frequency	f _{CP}	Duty=50%	–	–	6.0	MHz

2.3.AC Characteristics

V_{CC}=5.0V±10%

Parameter	Symbol	Min.	Max.	Units
CP Frequency	f _{CP}	–	6.0	MHz
Clock Pulse Width	t _{wC}	50	–	ns
Load Pulse Width	t _{wL}	63	–	ns
Data Setup Time	t _{SETUP}	30	–	ns
Data Hold Time	t _{HOLD}	30	–	ns
Clock Pulse Setup Time	t _{CL}	80	–	ns
Clock Pulse Hold Time	t _{LC}	110	–	ns
Rise/Fall Time	t _r , t _f	–	Note 1	ns
FLM Setup Time	t _{FDS}	100	–	ns
FLM Hold Time	t _{FDH}	100	–	ns

Note 1: The rise and fall times (t_r, t_f) must satisfy the following relationships (① and ②).

$$\textcircled{1} \quad t_r, t_f < \frac{1}{2f_{CP}} - t_{wC}$$

$$\textcircled{2} \quad t_r, t_f < 50 \text{ ns}$$

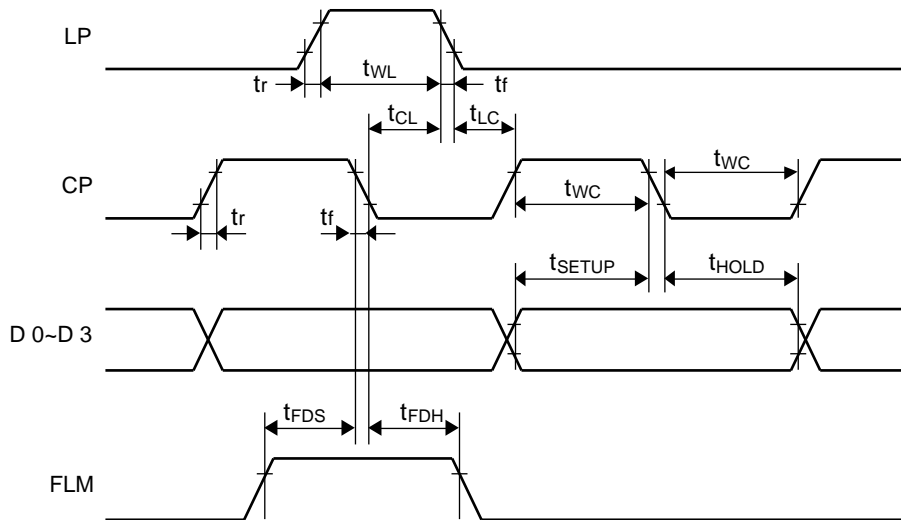

This module contains these capacitors. Please be careful about timing characteristics.

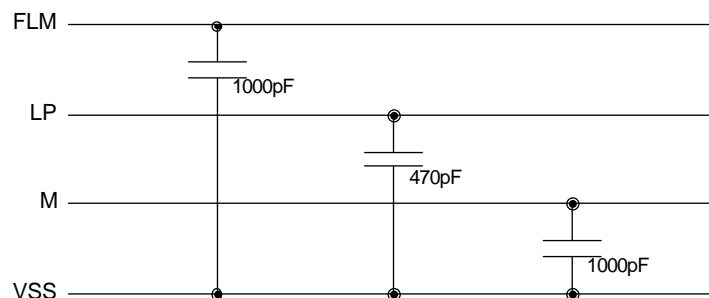

2.4. Timing Chart

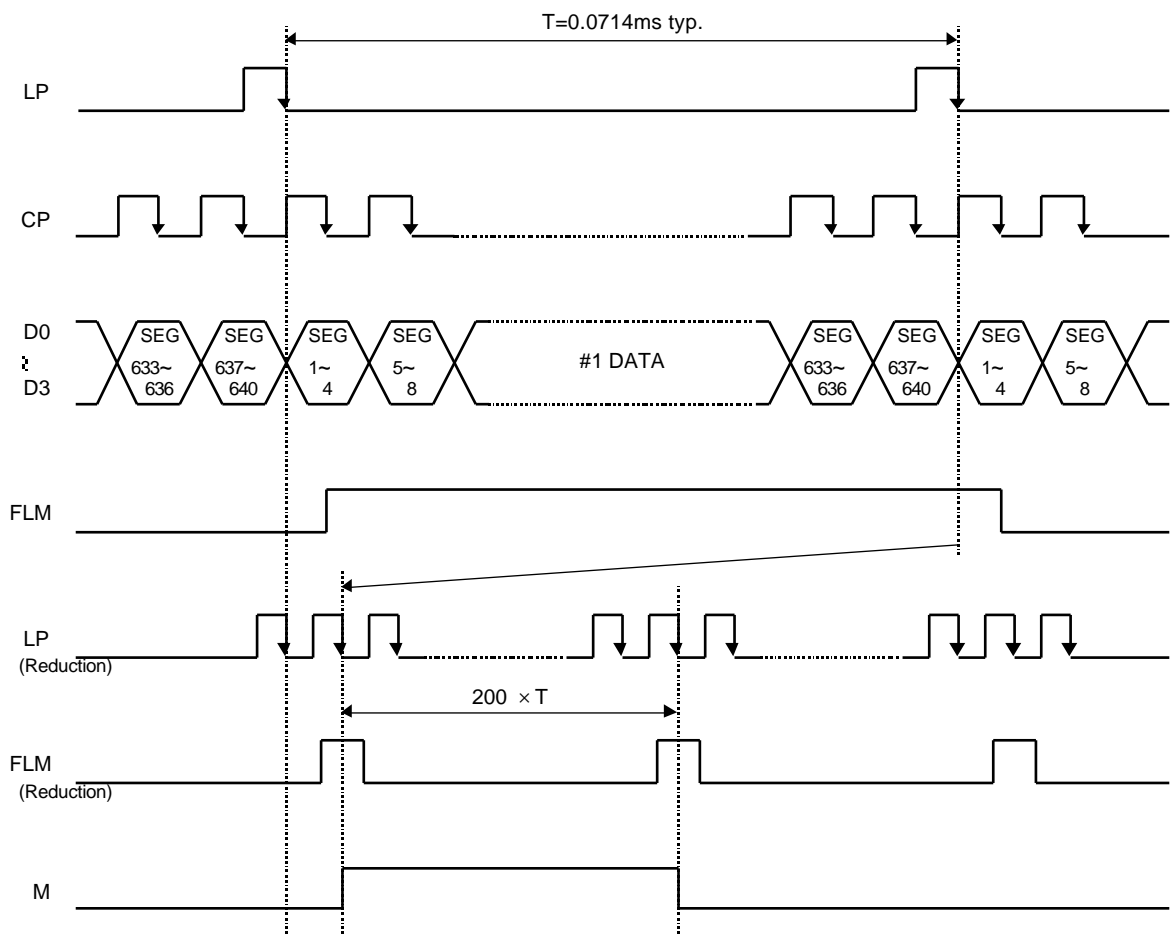

2.5. Comparison of Display and Data

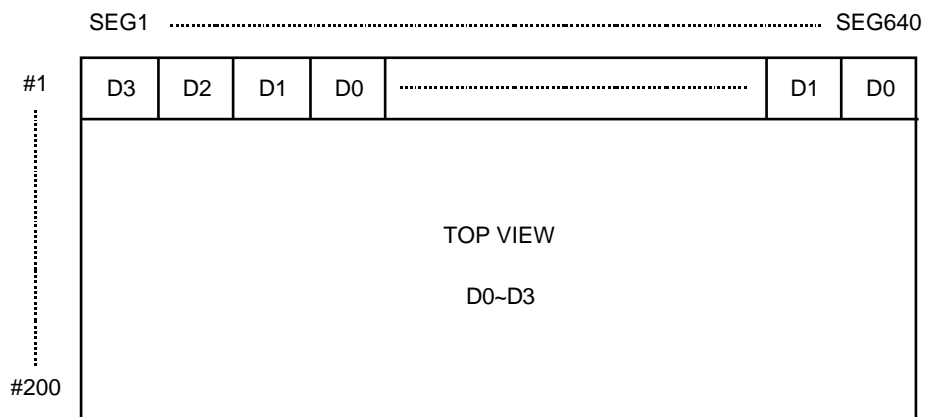

2.6. Power Supply ON/OFF Sequence

2.6.1. ON Sequence

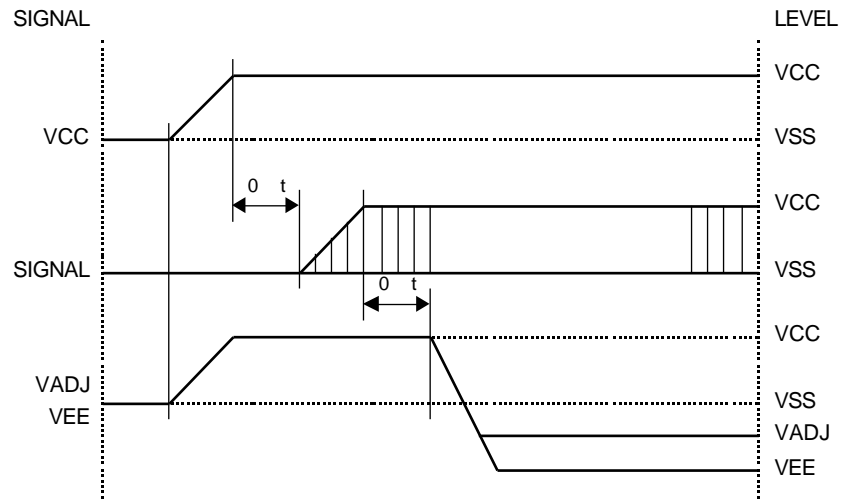

2.6.2. OFF Sequence

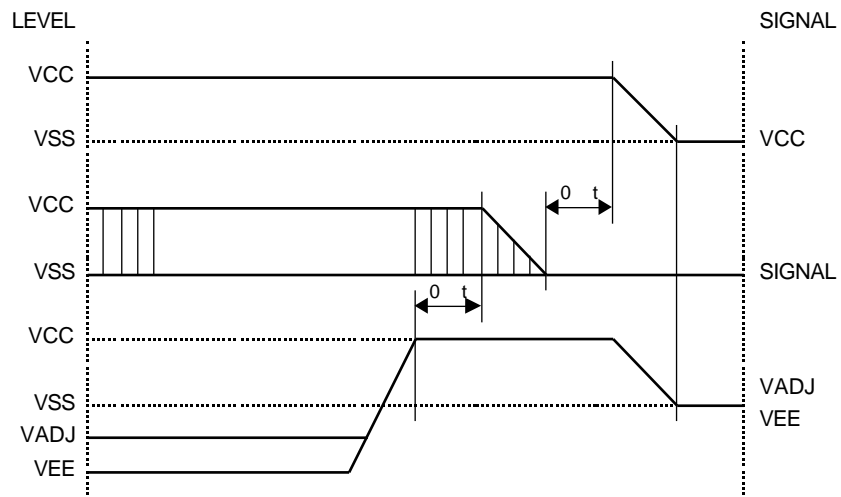

Please maintain the above sequence when turning on and off the power supply of the module. If **VEE** and/or **VADJ** is supplied to the module while internal alternate signal for LCD driving (M) is unstable, DC component will be supplied to the LCD panel. This may cause damage the LCD module.

2.7. Lighting Specifications

Ta=25°C

Parameter	Symbol	Conditions	Min.	Typ.	Max.	Units	Notes
Lamp Voltage	V _L	–	–	380	–	V _{rms}	1
Lamp Current	I _L	–	4.0	5.0	6.0	mArms	2
Starting Voltage	V _S	–	–	–	900	V _{rms}	3
Surface Luminance	L	I _L =5.0mA	50	–	–	cd/m ²	4
Average Life	T _{AL}	I _L =5.0mA	–	10000	–	hrs	5

Note 1 : The voltage (r.m.s.) to maintain the electric discharge of the lamp. It is measured after lighting for 3 minutes .

Note 2 : The current (r.m.s.) to flow through the lamp with the electric discharge. It is measured after lighting for 3 minutes.

Note 3 : The voltage at starting the electric discharge when the voltage is increased gradually from 0V.

Note 4 : Surface Luminance is specified by the initial data of luminance measured at the center of display surface after 20 minutes power on. (All ON pattern)

Note 5 : CFL life is defined as the time for which the initial luminance is attenuated by 50% of the luminance value. Average Life represents the time elapsed at the point of time when the residual ratio becomes below 50% when plural lamps are lighted in comparison with the definition of life mentioned above.

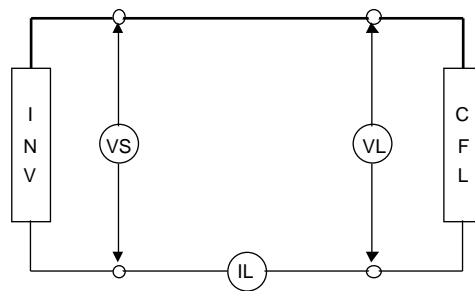

CFL Testing Circuit

3. Optical Specifications

3.1. LCD Driving Voltage

Parameter	Symbol	Conditions	Min.	Typ.	Max.	Units
Recommended LCD Driving Voltage Note 1	V _{CC} -V _{ADJ}	T _a =10°C	–	–	25.0	V
		T _a =25°C	20.7	22.2	23.8	V
		T _a =40°C	19.8	–	–	V

Note 1 : Voltage (Applied actual waveform to LCD Module) for the best contrast. The range of minimum and maximum shows tolerance of the operating voltage. The specified contrast ratio and response time are not guaranteed over the entire range.

3.2. Optical Characteristics

T_a=25°C, 1/200 Duty, 1/14 Bias, V_D=20.1V (Note 4), = 0°, = -°

Parameter	Symbol	Conditions	Min.	Typ.	Max.	Units
Contrast Ratio Note 1	CR	= 0°, = -°	–	10	–	
Viewing Angle		Shown in 3.3				
Response Time	Rise Note 2	T _{ON}	–	90	180	ms
	Decay Note 3	T _{OFF}	–	370	560	ms

Note 1 : Contrast ratio is defined as follows.

$$CR = L_{OFF} / L_{ON}$$

L_{ON} : Luminance of the ON segments

L_{OFF} : Luminance of the OFF segments

Note 2 : The time that the luminance level reaches 90% of the saturation level from 0% when ON signal is applied.

Note 3 : The time that the luminance level reaches 10% of the saturation level from 100% when OFF signal is applied.

Note 4 : Definition of Driving Voltage V_D

$$V_D = V_{CC} - V_{ADJ} - V_{BE}$$

Assuming that the typical driving waveforms shown below are applied to the LCD Panel at 1/A Duty - 1/B Bias (A : Duty Number, B : Bias Number). Driving voltage V_D is defined as follows.

$$V_D = (V_{th1} + V_{th2}) / 2$$

V_{th1} : The voltage V_{O-P} that should provide 50% of the saturation level in the luminance at the segment which the ON signal is applied to.

V_{th2} : The voltage V_{O-P} that should provide 50% of the saturation level in the luminance at the segment which the OFF signal is applied to.

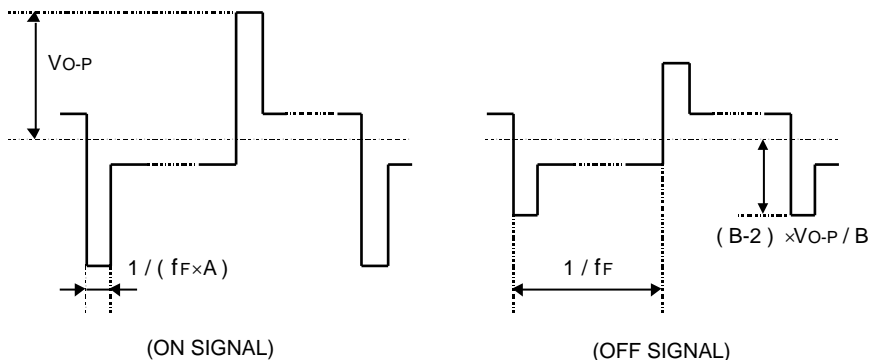

3.3. Definition of Viewing Angle and Optimum Viewing Area

- Point ● shows the point where contrast ratio is measured. : = 0°, = -°
- Driving condition : 1/200 Duty, 1/14 Bias, $V_D=20.1V$, $f_F=70Hz$

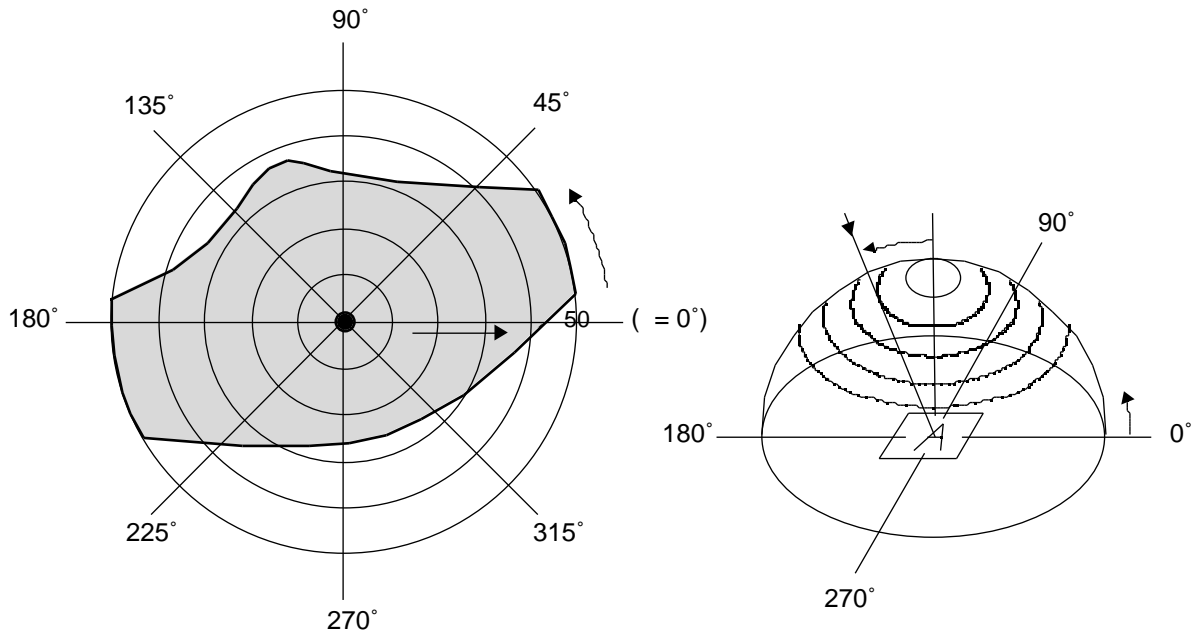

• Area  shows typ. CR 2

3.4. System Block Diagram

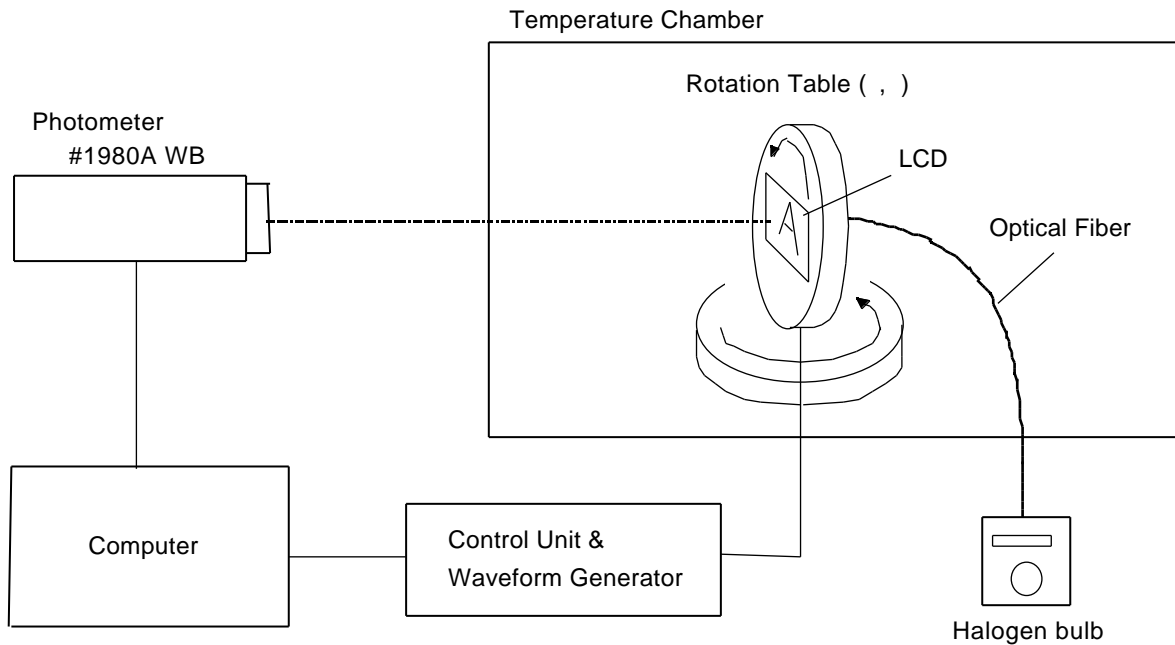

4. I/O Terminal

4.1. Pin Assignment

CN1

No.	Symbol	Level	Function
1	FLM	H / L	First Line Marker
2	LP	H L	Data Latch Signal
3	CP	H L	Clock Signal for Shifting Data
4	M	H / L	Alternate Signal for LCD Drive
5	V _{ADJ}	–	Voltage Level for LCD Contrast Adjustment
6	V _{CC}	–	Power Supply for Logic
7	V _{SS}	–	Power Supply (0V, GND)
8	V _{EE}	–	Power Supply for LCD Drive
9	D0	H / L	Display Data
10	D1	H / L	Display Data
11	D2	H / L	Display Data
12	D3	H / L	Display Data

CN3

No.	Symbol	Level	Function
1	FL (HOT)	–	Power Supply for CFL (HOT)
2	NC	–	Non-connection
3	NC	–	Non-connection
4	FL (GND)	–	Power Supply for CFL (GND)

4.2. Example of Power Supply

It is recommended to apply a potentiometer for the contrast adjust due to the tolerance of the driving voltage and its temperature dependence.

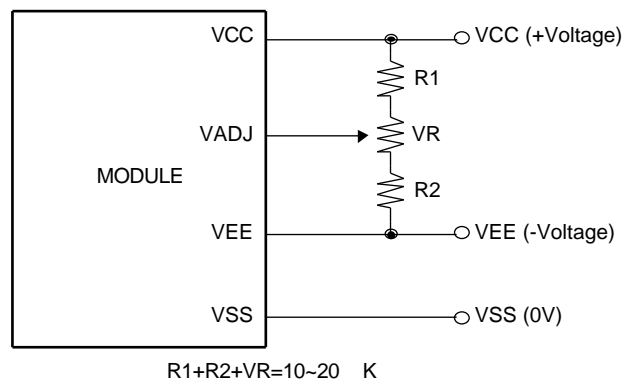

4.3. Block Diagram

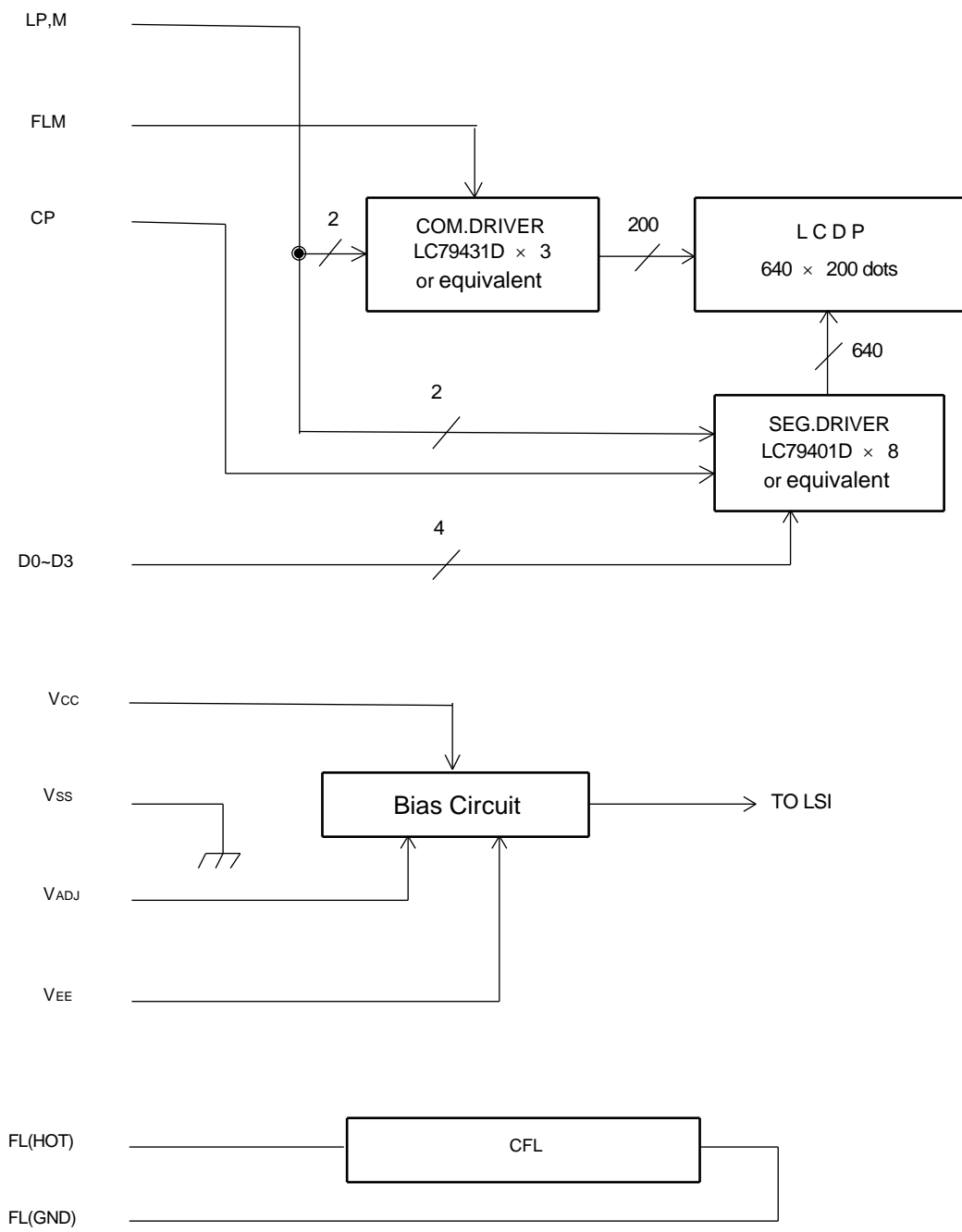

5. Test

No change on display and in operation under the following test condition.

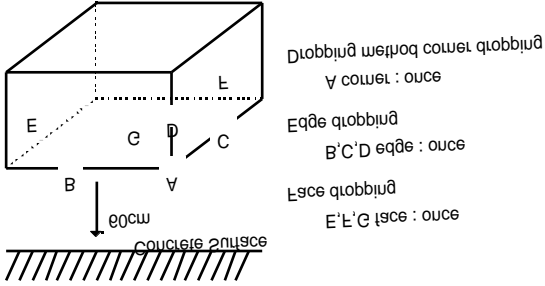
No.	Parameter	Conditions	Notes
1	High Temperature Operating	40°C±2°C, 96hrs (operation state)	
2	Low Temperature Operating	10°C±2°C, 96hrs (operation state)	3
3	High Temperature Storage	60°C±2°C, 96hrs	4
4	Low Temperature Storage	-20°C±2°C, 96hrs	3, 4
5	Damp Proof Test	40°C±2°C, 90~95%RH, 96hrs	3, 4
6	Vibration Test	Total fixed amplitude : 1.5mm Vibration Frequency : 10~55Hz One cycle 60 seconds to 3 directions of X, Y, Z for each 15 minutes	5
7	Shock Test	To be measured after dropping from 60cm high on the concrete surface in packing state. 	

Note 1 : Unless otherwise specified, tests will be conducted under the following condition.

Temperature : 20±5°C

Humidity : 65±5%

Note 2 : Unless otherwise specified, tests will be not conducted under functioning state.

Note 3 : No dew condensation to be observed.

Note 4 : The function test shall be conducted after 4 hours storage at the normal temperature and humidity after removed from the test chamber.

Note 5 : Vibration test will be conducted to the product itself without putting it in a container.

6. Appearance Standards

6.1. Inspection conditions

The LCD shall be inspected under 40W white fluorescent light.

The distance between the eyes and the sample shall be more than 30cm.

All directions for inspecting the sample should be within 45° against perpendicular line.

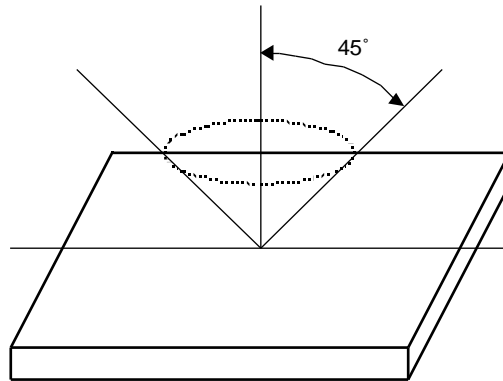

6.2. Definition of applicable Zones

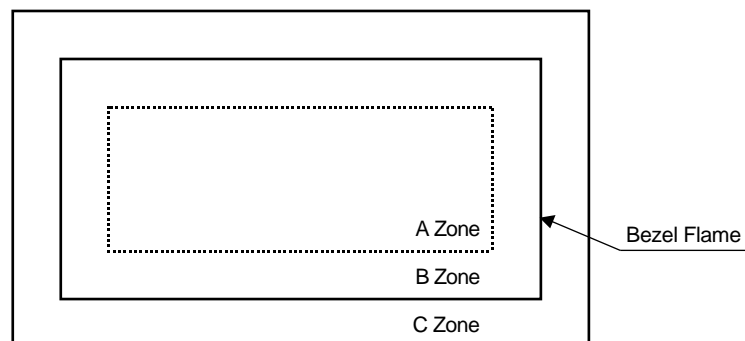

A Zone : Active display area

B Zone : Area from outside of "A Zone" to validity viewing area

C Zone : Rest parts

A Zone + B Zone = Validity viewing area

6.3. Standards

No.	Parameter	Criteria																																																									
1	Black and White Spots, Foreign Substances	<p>(1) Round Shape</p> <table border="1" data-bbox="608 322 1369 658"> <thead> <tr> <th rowspan="2">Dimension (mm) \ Zone</th> <th colspan="3">Acceptable Number</th> </tr> <tr> <th>A</th> <th>B</th> <th>C</th> </tr> </thead> <tbody> <tr> <td>D ≤ 0.1</td> <td>*</td> <td>*</td> <td>*</td> </tr> <tr> <td>0.1 < D ≤ 0.2</td> <td>3</td> <td>5</td> <td>*</td> </tr> <tr> <td>0.2 < D ≤ 0.3</td> <td>2</td> <td>3</td> <td>*</td> </tr> <tr> <td>0.3 < D ≤ 0.35</td> <td>0</td> <td>1</td> <td>*</td> </tr> <tr> <td>0.35 < D</td> <td>0</td> <td>0</td> <td>*</td> </tr> </tbody> </table> <p>D = (Long + Short) / 2 * : Disregard</p> <p>(2) Line Shape</p> <table border="1" data-bbox="608 752 1369 1043"> <thead> <tr> <th colspan="2">Zone</th> <th colspan="3">Acceptable Number</th> </tr> <tr> <th>X (mm) \ Y (mm)</th> <th></th> <th>A</th> <th>B</th> <th>C</th> </tr> </thead> <tbody> <tr> <td>-</td> <td>0.03 W</td> <td>*</td> <td>*</td> <td>*</td> </tr> <tr> <td>2.0 L</td> <td>0.05 W</td> <td>4</td> <td>4</td> <td>*</td> </tr> <tr> <td>1.0 L</td> <td>0.1 W</td> <td>4</td> <td>4</td> <td>*</td> </tr> <tr> <td>-</td> <td>0.1 < W</td> <td colspan="3">In the same way (1)</td> </tr> </tbody> </table> <p>X : Length Y : Width * : Disregard</p> <p>Total defects shall not exceed 7.</p>	Dimension (mm) \ Zone	Acceptable Number			A	B	C	D ≤ 0.1	*	*	*	0.1 < D ≤ 0.2	3	5	*	0.2 < D ≤ 0.3	2	3	*	0.3 < D ≤ 0.35	0	1	*	0.35 < D	0	0	*	Zone		Acceptable Number			X (mm) \ Y (mm)		A	B	C	-	0.03 W	*	*	*	2.0 L	0.05 W	4	4	*	1.0 L	0.1 W	4	4	*	-	0.1 < W	In the same way (1)		
Dimension (mm) \ Zone	Acceptable Number																																																										
	A	B	C																																																								
D ≤ 0.1	*	*	*																																																								
0.1 < D ≤ 0.2	3	5	*																																																								
0.2 < D ≤ 0.3	2	3	*																																																								
0.3 < D ≤ 0.35	0	1	*																																																								
0.35 < D	0	0	*																																																								
Zone		Acceptable Number																																																									
X (mm) \ Y (mm)		A	B	C																																																							
-	0.03 W	*	*	*																																																							
2.0 L	0.05 W	4	4	*																																																							
1.0 L	0.1 W	4	4	*																																																							
-	0.1 < W	In the same way (1)																																																									
2	Air Bubbles (between glass & polarizer)	<table border="1" data-bbox="608 1184 1369 1520"> <thead> <tr> <th rowspan="2">Dimension (mm) \ Zone</th> <th colspan="3">Acceptable Number</th> </tr> <tr> <th>A</th> <th>B</th> <th>C</th> </tr> </thead> <tbody> <tr> <td>D1, D2 ≤ 0.3</td> <td>*</td> <td>*</td> <td>*</td> </tr> <tr> <td>0.3 < D1, D2 ≤ 0.5</td> <td>3</td> <td>*</td> <td>*</td> </tr> <tr> <td>0.5 < D1 ≤ 0.7</td> <td>2</td> <td>3</td> <td>*</td> </tr> <tr> <td>0.5 < D2 ≤ 0.6</td> <td>2</td> <td>3</td> <td>*</td> </tr> <tr> <td>0.7 < D1, 0.6 < D2</td> <td>0</td> <td>0</td> <td>*</td> </tr> </tbody> </table> <p>D1 : Small foam a gathering D2 : Single foam * : Disregard</p> <p>Total defects shall not exceed 5.</p>	Dimension (mm) \ Zone	Acceptable Number			A	B	C	D1, D2 ≤ 0.3	*	*	*	0.3 < D1, D2 ≤ 0.5	3	*	*	0.5 < D1 ≤ 0.7	2	3	*	0.5 < D2 ≤ 0.6	2	3	*	0.7 < D1, 0.6 < D2	0	0	*																														
Dimension (mm) \ Zone	Acceptable Number																																																										
	A	B	C																																																								
D1, D2 ≤ 0.3	*	*	*																																																								
0.3 < D1, D2 ≤ 0.5	3	*	*																																																								
0.5 < D1 ≤ 0.7	2	3	*																																																								
0.5 < D2 ≤ 0.6	2	3	*																																																								
0.7 < D1, 0.6 < D2	0	0	*																																																								

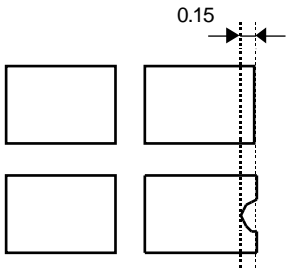
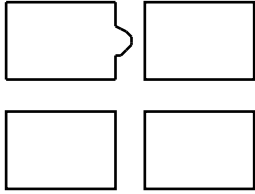
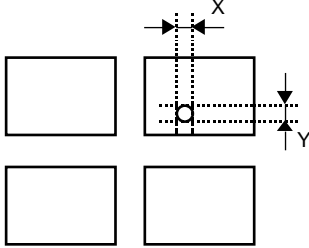
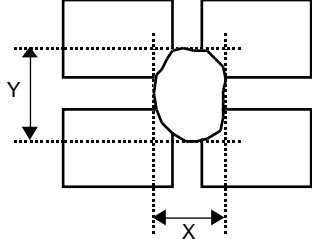
No.	Parameter	Criteria
3	The Shape of Dot	<p>(1) Dot Shape (with Dent)</p>  <p>As per the sketch of left hand.</p> <p>(2) Dot Shape (with Projection)</p>  <p>Should not be connected to next dot.</p> <p>(3) Pin Hole</p>  <p>$(X+Y) / 2 \leq 0.2\text{mm}$ (Less than 0.1mm is no counted.)</p> <p>(4) Deformation</p>  <p>$(X+Y) / 2 \leq 0.2\text{mm}$</p> <p>Total acceptable number : 1/dot, 5/cell (Defect number of (4) : 1pc.)</p>
4	Polarizer Scratches	Not to be conspicuous defects.
5	Polarizer Dirts	If the stains are removed easily from LCDP surface, the module is not defective.
6	Complex Foreign Substance Defects	Black spots, line shaped foreign substances or air bubbles between glass & polarizer should be 7pcs maximum in total.
7	Distance between Different Foreign Substance Defects	$D \geq 0.2$: 20mm or more $0.2 < D$: 40mm or more

7. Code System of Production Lot

The production lot of module is specified as follows.

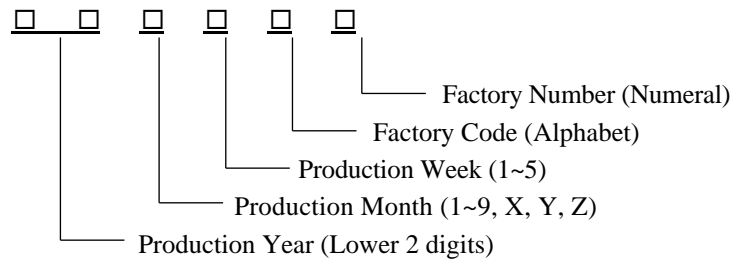

8. Type Number

The type number of module is specified on the back of module as follows.

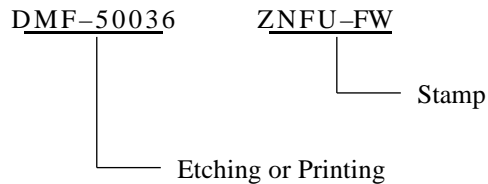

9. Applying Precautions

Please contact us when questions and/or new problems not specified in this specifications arise.

10. Handling Precautions

Optrex Products are designed for use in ordinary electronic devices such as business machines, telecommunications equipment, measurement devices and etc..

Optrex Products are not designed, intended, or authorized for use in any application in which the failure of the product could result in a situation where personal injury or death may occur. These applications include, but are not limited to, life-sustaining equipment, nuclear control devices, aerospace equipment, devices related to hazardous or flammable materials, etc. (If Buyer intends to purchase or use the Optrex Products for such unintended or unauthorized applications, Buyer must secure prior written consent to such use by a responsible officer of Optrex Corporation.) Should Buyer purchase or use Optrex Products for any such unintended or unauthorized application (without such consent), Buyer shall indemnify and hold Optrex and its officers, employees, subsidiaries, affiliates and distributors harmless against all claims, costs, damages and expenses, and reasonable attorney's fees, arising out of, directly or indirectly, any claim of personal injury or death associated with such unintended or unauthorized use, even if such claim alleges that Optrex was negligent regarding the design or manufacture of the part.

- 1) LCD may be broken because it is made of glass.
- 2) Polarizer is a soft material and can easily be scratched.
- 3) Please avoid static electricity.
 - ① Please be sure to ground human body and electric appliances during work.
 - ② It is preferable to use conductive mat on table and wear cotton clothes or conduction processed fiber. Synthetic fiber is not recommended.
 - ③ Please slowly peel off protective film, because static electricity may be charged.
- 4) If it is necessary to store LCD modules for a long time, please comply with the following procedures. If storage condition is not satisfactory, display (especially polarizer) may be deteriorated or soldering I/O terminals may become difficult (some oxide is generated at I/O terminals plating).
 - ① Store as delivered by Optrex
 - ② If you store as unpacked, put in anti-static bag, seal its opening and store where it is not subjected to direct sunshine nor fluorescent lamp.
 - ③ Store at temperature 0 to +35°C and at low humidity. Please refer to our specification sheets for storage temperature range and humidity condition.
- 5) The module does not contain excess current limiter.
Please design the limiter to cut excess current in your power supply circuit.
- 6) Liquid crystal may be leaked when display is broken. Never taste it. If your hands or clothes touch it, please immediately wash using soap.
- 7) The connection between the bezel and Vss (GND) is not specified in the module.
(Some module do not maintain connection between them.)
Please consult OPTREX to specify the connection.
- 8) A high voltage over 1000V is applied at the connector of CFL cable when the CFL inverter is connected and energized. Please do not touch there incidentally or accidentally to avoid a skin burn.
And please set the cable properly in the housing to avoid a worn-out of isolated cover of cable wire.

Optrex shall not be responsible for any infringement of industrial property rights of third parties in any country arising out of the application or use of Optrex Products, except which directly concern the structure or production of such products.