

Apex Material Technology Corp. 創為精密材料股份有限公司

AMT PRODUCT STANDARD

Doc No:	AS-09513-B1	Doc Rev: 1.0
Title:	SPECIFICATIONS OF ANALOG RESISTIVE TOUCH SCREEN	Released: JULY.20,2005
	Part Number : 9513 Rev:B	Page. 1 of 7

Analog Touch Screen Specification

Manufacture: Apex Material Technology Corp.

Part No. : 9513 Rev:B

1. Mechanical Dimensions and Construction

1.1 General: Analog Resistive touch screen is laminated by ITO PET to ITO glass.

1.2 Construction :

Item	Description	Material	Remarks
1	Top layer	0.188mm ITO PET	Antiglare coating Surface hardness: 3H Resistance:300~600 /
2	Bottom layer	1.10mm ITO Glass	Resistance:300~600 /
3	Tail Base	PET	Separated Tail
4	Tail Coverlay	PET	
5	Connector	AMP Compatible	Pitch : 2.54mm
6	Top layer circuit	Silver ink	
7	Bottom layer circuit	Silver ink	
8	Layer to layer contacted	Silver Glue	
9	Dot spacer	Resin Polymer	
10	Isolation Layer	Double Side Adhesive	
11	Glue	UV Glue	

Remark : This model is with ANR design.

Touch screen side view:

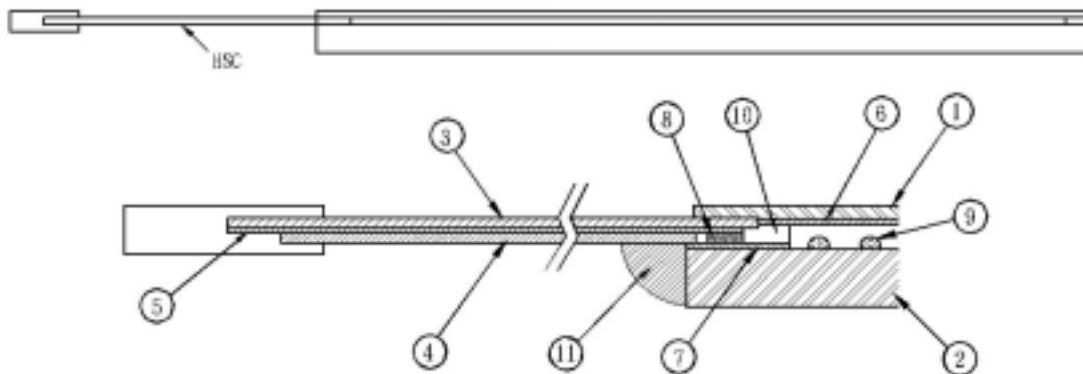

Apex Material Technology Corp.
創為精密材料股份有限公司

AMT PRODUCT STANDARD

Doc No:	AS-09513-B1	Doc Rev: 1.0
Title:	SPECIFICATIONS OF ANALOG RESISTIVE TOUCH SCREEN	Released: JULY.20,2005
	Part Number : 9513 Rev:B	Page. 2 of 7

1.3 Input Method and Activation Force

Input Method	Average Activation Force
1.6mm dia. Delrin stylus	0.10~0.70N
16mm dia. Silicon "finger"	0.10~0.80N

2. Typical Optical Characteristics

2.1 Visible Light Transmission: >80%

2.2 Haze:< 13%

3. Electrical Specifications

3.1 Operating Voltage: 5.5V or less

3.2 Contact current: 20mA (maximum)

3.3 Circuit close resistance: X : 400~1000
Y : 200~650

3.4 Circuit open resistance: > 10M at 25VDC

3.5 Contact bounce: < 10ms

3.6 Linear Test : <1.5 %

3.7 Capacitance:100nF(maximum)

4. Linearity

4.1 Linear Test Specification

Direction X: <1.5 %

Direction Y: <1.5 %

4.2 Linearity Test

Apply voltage (DC5V) to upper (or lower) electrodes, output voltage Vx (see Fig.4-1) or Vy (see Fig.4-2) on the other electrodes is measured at every regular intervals.

Linearity is the value of max. error voltage (see Fig. 4-3).

Apex Material Technology Corp.
創為精密材料股份有限公司

AMT PRODUCT STANDARD

Doc No:	AS-09513-B1	Doc Rev: 1.0
Title:	SPECIFICATIONS OF ANALOG RESISTIVE TOUCH SCREEN	Released: JULY.20,2005
	Part Number : 9513 Rev:B	Page. 3 of 7

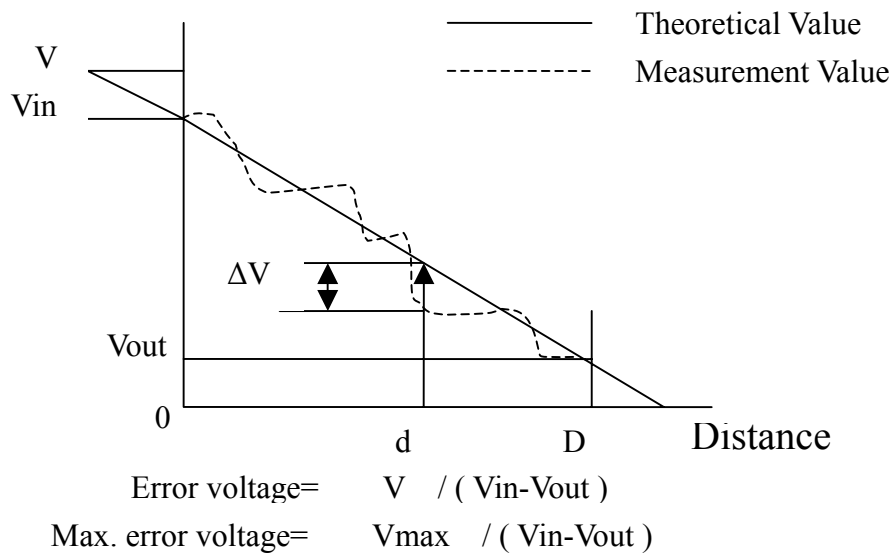
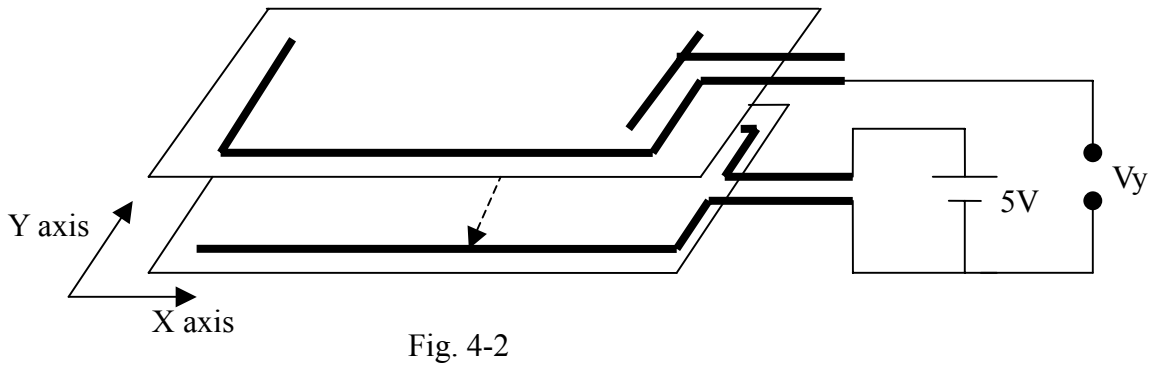
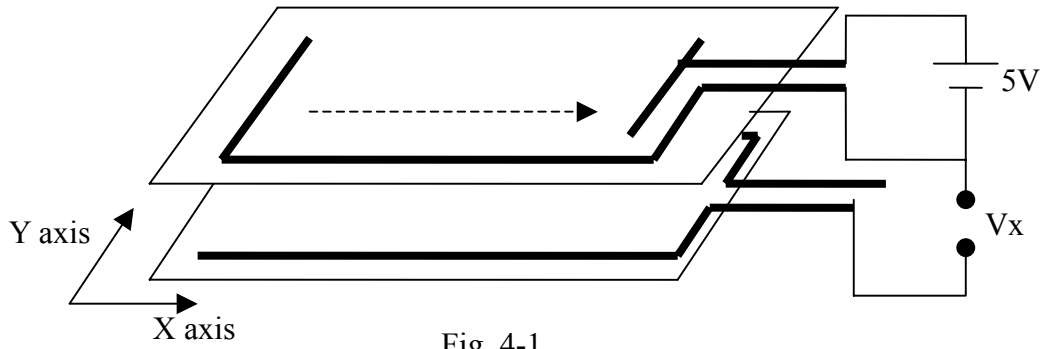

Apex Material Technology Corp.
創為精密材料股份有限公司

AMT PRODUCT STANDARD

Doc No:	AS-09513-B1	Doc Rev: 1.0
Title:	SPECIFICATIONS OF ANALOG RESISTIVE TOUCH SCREEN	Released: JULY.20,2005
	Part Number : 9513 Rev:B	Page. 4 of 7

5. Environment Specification

- 5.1 Operating Temperature -10° C ~ + 60° C
 Humidity less than 80% RH
 No dew condensation
- 5.2 Storage Temperature -40° C ~ + 80° C
 at Ambient Humidity

6. Reliability Test

6.1 Exposure to high temperature

Touch panel is put into a test machine at the condition of 80 for 120 hours.
Then it is left at the room temperature for 24 hours or more. The measurement
must satisfy the following:

- Circuit close resistance: as Sec. 3.3
- Circuit open resistance: as Sec. 3.4
- Contact bounce: as Sec. 3.5
- Linearity test: as Sec. 3.6

6.2 Exposure to low temperature

Touch panel is put into a test machine at the condition of -40 for 120 hours.
Then it is left at the room temperature for 24 hours or more. The measurement
must satisfy the following:

- Circuit close resistance: as Sec. 3.3
- Circuit open resistance: as Sec. 3.4
- Contact bounce: as Sec. 3.5
- Linearity test: as Sec. 3.6

Apex Material Technology Corp.
創為精密材料股份有限公司

AMT PRODUCT STANDARD

Doc No:	AS-09513-B1	Doc Rev: 1.0
Title:	SPECIFICATIONS OF ANALOG RESISTIVE TOUCH SCREEN	Released: JULY.20,2005
	Part Number : 9513 Rev:B	Page. 5 of 7

6.3 Exposure to constant temperature and humidity

Touch panel is put into a test machine at the condition of 60 , 90%RH for 120 hours. Then it is left at the room temperature for 24 hours or more. The measurement must satisfy the following:

- Circuit close resistance: as Sec. 3.3
- Circuit open resistance: as Sec. 3.4
- Contact bounce: as Sec. 3.5
- Linearity test: as Sec. 3.6

6.4 Thermal Shock

Touch panel is put into a test machine at the condition of -40 for 30 minutes, and then 80 for 30 minutes. The process is repeated by 10 cycles. Then it is left at the room temperature for 24 hours or more. The measurement must satisfy the following:

- Circuit close resistance: as Sec. 3.3
- Circuit open resistance: as Sec. 3.4
- Contact bounce: as Sec. 3.5
- Linearity test: as Sec. 3.6

7. Durability test:

7.1 Finger touches

Touch panel is hit 10 millions times with a silicone rubber of R8 finger(see Fig.7-1), hitting rate is by 250g at 2 times per second. The measurement must satisfy the following:

- Circuit close resistance: as Sec. 3.3
- Circuit open resistance: as Sec. 3.4
- Contact bounce: as Sec. 3.5
- Linearity test: as Sec. 3.6

Apex Material Technology Corp.
創為精密材料股份有限公司

AMT PRODUCT STANDARD

Doc No:	AS-09513-B1	Doc Rev: 1.0
Title:	SPECIFICATIONS OF ANALOG RESISTIVE TOUCH SCREEN Part Number : 9513 Rev:B	Released: JULY.20,2005
		Page. 6 of 7

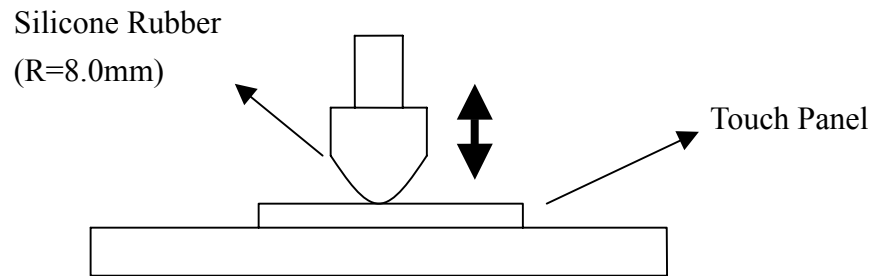

Fig. 7-1

7.2 Stylus writing

Touch panel is drawn by R0.8 Derlin stylus pen, at 250g forces, repeat one inch by 100K times(see Fig.7-2). The measurement must satisfy the following:

- Circuit close resistance: as Sec. 3.3
- Circuit open resistance: as Sec. 3.4
- Contact bounce: as Sec. 3.5
- Linearity test: as Sec. 3.6

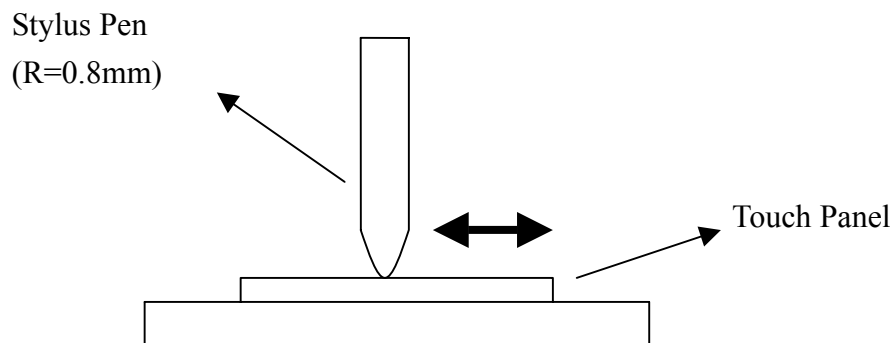

Fig. 7-2

Apex Material Technology Corp.
創為精密材料股份有限公司

AMT PRODUCT STANDARD

Doc No:	AS-09513-B1	Doc Rev: 1.0
Title:	SPECIFICATIONS OF ANALOG RESISTIVE TOUCH SCREEN	Released: JULY.20,2005
	Part Number : 9513 Rev:B	Page. 7 of 7

8. Optical Performance

8.1 Optical inspection method and optical defect standards refer to AMT document. A001 updated version ; "Touch Screen Optical Quality Standard."

8.2 Outside to Viewing Area : any optical defected in this area need to be ignored if no effected to touch screen function.

8.3 Others

8.3.1 Always store the touch screen in its original shipping container under normal conditions(20~25 65%RH)

8.3.2 All specifications subject to change without notice.